

# Industrial Products Source

ISSN 0973-1857

A Magazine for Indian Industries

Vol 20

Issue 2

February 2023

₹ 30/-

A Product News Publication

Total no. of pages 60

Visit: [www.ips.co.in](http://www.ips.co.in)  
to view our e-magazine

**Focus:**  
Machine Tools &  
Auto Components Accessories

Products Index  
Page 54

## HOUSE OF CAPACITORS



AC Capacitors (MFD)



Oil Filled  
Power Capacitors



Phase Cap  
Capacitors



Cylindrical Type  
Power Capacitors



Gas Filled Power  
Capacitors



Modular Dry Type  
Power Capacitors



APFC  
Control Panel



Power Factor  
Controller

AC CAPACITORS: IN PP & AL CAN 250V - 600V

POWER CAPACITORS: MPP Dry Type, Oil Filled, Heavy Duty, Heavy Duty Long Life, Super Heavy Duty, Gas Filled, APP Type, Mixed Dielectric Type, High Tension, Water Cooled, Also Available Medium & High Tension Capacitors, Medium Frequency, Single Protect, Energy Storage Capacitors, Electronic DC Capacitors Power Factor Relays.

### SHREE TRADING SYNDICATE

(An ISO 9001:2008 Company)

# 4, Ground Floor, Kesar Building, 201 / 211, Princess Street, Mumbai 400 002

Tel: 022-6634 8274 / 75 • Email: [pradeep@shreetrading.com](mailto:pradeep@shreetrading.com) / [sales@shreetrading.com](mailto:sales@shreetrading.com)

Coimbatore Branch: 57A, Dr.Nanjappa Road, Coimbatore 640 018.

Tel: 0422-230 1619 • Cell: 0 93613 21367 • E-mail: [balajiraja@shreetrading.com](mailto:balajiraja@shreetrading.com)

Website: [www.shreetrading.net](http://www.shreetrading.net)



Authorised Dealers & Exporters of:



We are a national level company manufacturing & supplying for THIRTY FIVE YEARS to OEMs & user/govt depts. Complete range of control gear for EOT Cranes such as Lever Limit Switches, Counter Weight Limit Switches, Rotary Geared Limit Switches, Differential Limit Switches, Master Controllers, Pendant Push Button Stations [IP-65], Electro Hydraulic Thruster Brakes, Electro Hydraulic Thrusters, Electro Magnetic Brakes, S S Punched Grid Resistance Boxes, Radio Remote Control, Shrouded Bus Bar System, C-Track Flexible Trailing System, Flexible Geared Couplings, Brake Drum Couplings, Cable Trolleys, Cables Reeling Drums, Gear Boxes, Crane Wheels, Digital Crane Scales, Load Cells, Anti-Collision Devices, Arm Chairs etc.

**CRANE CONTROL EQUIPMENTS**  
Office & Works: B-249, Okhla Industrial Area, Phase - I, New Delhi - 110 020.  
Tel: 011-4101 6403 to 405 • Mob: +91-98100 09466, 93100 09466  
E-mail: [info@cranecontrolequipments.com](mailto:info@cranecontrolequipments.com) / [sales@cranecontrolequipments.com](mailto:sales@cranecontrolequipments.com)  
Web: [www.cranecontrolequipments.com](http://www.cranecontrolequipments.com) / [www.cranecontrolequipments.net](http://www.cranecontrolequipments.net)



www.kadkraft.com

### SMARTTECH 3D scanner

World's highest resolution  
20-20 Mpixel scanner

VDI 2634 certified

FOR  
Reverse Engineering &  
Quality Inspection



### KISSsoft

World's most popular software  
for Gearbox design

Available Latest Version 2022

DISTRIBUTOR FOR INDIA

KADKRAFT SYSTEMS PVT. LTD.

D-133/B, Phase 7, Industrial Area, Mohali 160055, Punjab.

+91 - 98143 62601, +91 - 90231 72022

E-mail: [contact@kadkraft.com](mailto:contact@kadkraft.com)



# Ventura Alloy and Steels Private Limited

We are Importer, Exporter, Stockist, Distributor & Suppliers for  
 Tool & Alloy - Special and Die Steels, Forging Components Spring Steel - Wire Rod, Square & Round Bars  
 Coiled & Disc Springs, Tools Collets, Impact Sockets Etc.



**HOT WORK  
TOOL STEELS**



**COLD WORK  
TOOL STEELS**



**PLASTIC MOULD STEELS**



**ALLOY STEELS**



**SPRING STEELS**

**HOT WORK STEEL (IND/USA/EUR)**

DB6 / AISI L6 / DIN2714  
 H13 / AISI H13 / DIN 2344  
 H11 / AISI H11 / DIN 2343  
 H21 / AISI H21 / DIN 2581  
 H10 / AISI H10 / DIN 2365  
 H12 / AISI H12 / DIN 2606

**COLD WORK STEEL (IND/USA/EUR)**

HCHCR-D2/AISI D2/DIN 2379 | A2/AISI A2/DIN 2363  
 HCHCR-D3/AISI D3/DIN 2080 | O1/AISI O1/DIN 2510  
 D5/ Cr12MoV/DIN 2601

**PLASTIC MOULD STEEL (IND/USA/EUR)**

P20+Ni/AISI P20+Ni/DIN 2738  
 P20/AISI P20/DIN 2311

**ALLOY STEEL (IND/USA/EUR)**

EN24/AISI 4340/40NiCrM084 / 34CrNiMo6  
 EN19/AISI 4140/42CrMo4  
 EN31/AISI 52100/100Cr6  
 20MnCr5  
 SAE8620

**SPRING STEEL**

EN47 / 50CrV4 / 51CrV4 / AISI 6150 / SUP10 / DIN 8159  
 SUP9 / AISI 5155 / DIN 1.7176  
 SAE 9254 / AISI 9254

**CARBON STEEL**

SAE1018 MS  
 C45 / EN8D  
 EN1A  
 EN1A Pb

**Head Office**

Unit No. 1201 & 1202, Ghanshyam Enclave,  
 New Link Road, Near Laljipada Police Station, Kandivali (West),  
 Mumbai : 400067.  
 Tel.: +91 22 35034301 - 307 / 35034311 - 319 |  
 Mob.: 9819225666 & 8591313565

**Stocking/ Machining Centre**

Gala No. 6, Building No. 183, Indian Corporation, Mouje Gundavli  
 (Mankoli - Phata) Dapoda, Taluka - Bhiwandi : 421302  
 Tel : +91 7977097655 | 7977097657  
 Email: sales@venturasteels.com | Web: www.venturasteels.com

**SOVEREIGN SOLUTIONS FOR ALLOY, SPRING AND DIE STEELS**

www.venturasteels.com | sales@venturasteels.com | +91 22 35034301 - 307 / 35034311 - 319 | 9819225666 & 8591313565



# Think Temperature Sensing Think **british** ELECTRICALS

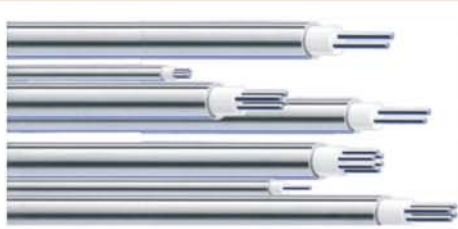

M.I. Thermocouple Cables



Thermocouple Cables



Thermocouple Connectors



Lab Furnaces

## Infrared Heater - Short wave



Code	Heated HL (mm)	Length OL (mm)	Overall Length (W)	Wattage Voltage (V)
SW500	127	212	500	240
SW1000	254	348	1000	240
SW1600S	406	500	1600	240
SW1600D	406	500	1600	415
SW2000S	508	626	2000	240
SW2000D	508	626	2000	415
SW2500D	635	728	2500	415
SW3000S	508	626	3000	240
SW3000D	765	1120	3000	415

All the above lamps are with round ceramic cap and 100mm long lead wire at both ends. For horizontal mounting application only



Temperature Transmitters

## Ceraheat

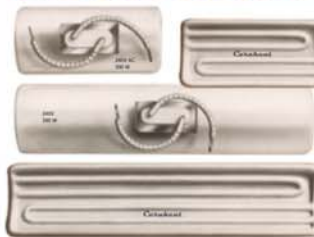

Ceraheat Ceramic I/R heaters for Industrial Heating / Baking are available in following wattage and sizes

SIZE	WATTS
245 x 60HSC	650W 1000W
120 x 60HSC	350W 500W
120 X 120 HSF	500W 1000W

Also available with embedded T / couple "K"



Relative Humidity & Temperature Transmitters

Ceramic Infrared Heater



Thermocouple Assemblies & Thermowells



Pushbutton Switches



Ceramic Wire Wound - RTD

Film Type - RTD



LED Panel Indicators



**british**  
ELECTRICALS

237/8, Sonal Link Industrial Estate, Building No: 2, Link Road, Malad (W), Mumbai 400 064  
Tel. : 022 - 4062 0000 • Fax : 022 - 4062 0099  
E-mail: sales@britishelectricals.com Website: www.britishelectricals.com



SERVICE TO INDUSTRIES SINCE 1971

## Industrial Products Source

(A Product News Publication)

Vol. 20 No. 2 February 2023

**Editor & Publisher:** Mohanan N  
Mobile: 098206 70855

**Sub Editor:** Ramachandran. T  
✉: ipseditor@gmail.com

**Marketing Manager:** V Madanmohan  
Mobile: 098208 38998

**Layout Artist:** Chandrakant G. Kadam

*Single copy price: ₹30/-*

*Annual Subscription: ₹300/-*

### Regd Office

A/10 Jayshree Laxmi Puja CHS, Plot No: 78/82  
Ramachandra Nagar, Dombivli (E), Thane 421 201

### Editorial, Marketing & Advertising

104 Sudama Yash  
Nr: Ramkrishna Hotel, Kelkar Cross Road, Ram Nagar,  
Dombivli (E), Thane 421 201  
✉: ipsmaginfo@gmail.com  
ipsmag@yahoo.com

### Representatives

**Coimbatore:** Rajeev Kumar, Mobile: 094431 29073

**Industrial Products Source** is a product news  
monthly publication, registered with the Registrar of  
Newspapers for India,  
under No: MAHENG/2004/12919.

**Industrial Products Source** reserves the right  
to use the information published herein in any manner  
whatsoever. The Editor/Publisher to the best of their ability  
have tried to check the accuracy of information published in  
this issue which is based on the material supplied by respec-  
tive manufacturers/agents/advertising agencies.

Neither **Product News Publication**  
nor any of its employees will be morally or legally  
responsible for any errors or omission. No part of this  
publication may be reproduced in any form without the  
written permission of the publisher. All rights reserved.

Printed and Published by Mohanan N  
on behalf of **Product News Publication**  
and printed at Perfect Prints,  
22/23 Jyothi Industrial Estate  
Noori Baba Darga Road, Near Makhmali Talao  
Thane 400 601, and published from  
A/10 Jayshree Laxmi Puja CHS, Plot No: 78/82  
Ramachandra Nagar,  
Dombivli (E), Dist: Thane 421 201.

Editor: Mohanan N

## CONVEYORS & COMPONENTS



### A WIDE RANGE TO CHOOSE

- Slats in Delrin, S.S., M.S
- Multi Directional
- Universal Flex
- Stackable
- Min / Backline Force
- Nylon, MS, SS Sprockets
- Brackets + Guides
- Clamps for Photo Cells
- Cartonator Pockets
- Tripod & Bipod
- Modular Supports

 **moldex corporation**

A-9, New Empire Industrial Estate, Kondivita Road, J.B. Nagar  
Andheri (E), Mumbai 400 059  
Phone: 022 - 4015 5959 • Mob: 99200 52389  
E-mail: info@moldex.in / krish@moldex.in  
Website: www.moldex.in

**Pankaj**  Always moving...innovative products developments

**Rotary Conductive Plastic Servo Potentiometer - Model: RCP-22**



Aluminum Housing	Ø 22 mm x L 12 mm
Metal Shaft	Ø 6.35 mm x L 15 mm
Mechanical Angle of Rotation	360°
Effective Electrical Angle	(1) 340° (2) 100° (3) 60°

**Short Stroke Conductive Plastic Potentiometer**



LCP - 10 10 mm Travel  
LCP - 20 20 mm Travel

20 mm Sq., flange mounting  
Resistance: 1K, 5K, 10KΩ  
Supplied with wires and connector



19 mm  25 mm  
High Engineering  
Plastic Shaft 1 Watt. Res. 25 to 25KΩ  
24mm Φ x 16mm Height

Manufacturers & Exporters: **Pankaj POTENTIOMETERS PVT. LTD.**  

201-B, Udyog Mandir No.1, 7-C, Pitamber Lane, Mahim, Mumbai 400 016, India  
Tel. : +91 22 2446 5778 • Mobile : +91 98690 50801  
E-mail : pankaj.potentiometers@gmail.com • Website: www.pankaj.com

# Bulk Material Handling Systems Product Range



BELT CONVEYORS



PIPE CONVEYORS



PULSE JET BAG FILTER



VERTICAL SHAFT IMPACTOR



SINGLE TOGGLE JAW CRUSHER



CONE CRUSHER



VIBRATING GRIZZLY FEEDER /  
VIBRATING FEEDER



RESONANCE SCREEN



BRUTE FORCE SCREEN



IMPACT HAMMER CRUSHER



AUTOMATED REFERENCE  
METHOD SAMPLER



HIGH FREQUENCY SCREEN

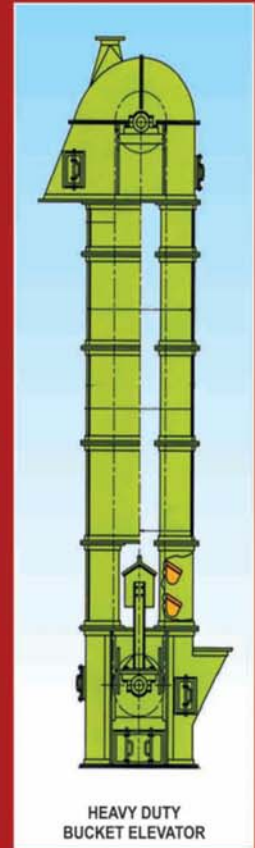

HEAVY DUTY  
BUCKET ELEVATOR

We Also Undertake Turnkey Execution of  
Cement Grinding Units

## Quality Policy

*To be customer's delight and achieve allround excellence.  
To strive for continuous improvement in business performance  
through commitment of all employees.*



**MASYC**  
ISO 9001 : 2008 CERTIFIED CO



## MASYC PROJECTS PVT. LTD.

23, Community Centre, Mayapuri, Phase-I, New Delhi-110064  
Tel : +91-11-2811 5453, 2811 5745, 2811 3383 Fax : +91-11-2811 6850  
E-mail: [masyc@masycproject.com](mailto:masyc@masycproject.com) Website : [www.masycproject.com](http://www.masycproject.com)

## Surface Grinding Machine (Manual)

Universal Machine Tools Corporation offers a wide range of Surface Grinding Machine (manual). Features: the machine is built of heavy cast iron hand scrapped to fine tolerance, easy movement of table slide by providing V – ways and flat ways; the grinding wheel spindle is hardened and round and runs in precision contact angular bearing and driven by flange, vertical grinding wheel slide movement down at right side in the body; the vertical wheel dial least count in 0.01mm and micro feed least count in 0.001 mm; these machines are available in various sizes: 450 X 225 mm , 600 X 300 mm; and also available in hydraulic version. The company established in 1981, is one of the leading companies in the machine tool industry.



Contact:

**Universal Machine Tools Corporation**  
 No. 109, SSI Area, Opposite St. Anns School  
 Dr Rajkumar Road, 5 Block, Rajajinagar  
 Bengaluru, Karnataka 560 010  
 ☎ 080 – 2335 6231, 2310 8370, 2320 6821  
 Mob: 98450 06959  
 E-mail: [universalblr@gmail.com](mailto:universalblr@gmail.com)

## Kusam-Meco True RMS Digital Clampmeter Model KM 2719

Kusam-Meco has introduced a new Clampmeter Model KM 2719 which is an upgraded version of their earlier Model KM-2718. The instrument is suitable for HVAC measurements. The new Clampmeter has 11 functions & 37 Ranges. It has 4000 counts display. The Measurement is True RMS measurement. It measures AC current upto 400 amperes (frequency response 50Hz -100Hz). It has AC Voltage range upto 600 Volts (Frequency response 10Hz - 10KHz) with a resolution 1mV. It has DC Voltage Range upto 600 Volts with resolution 0.1mV. The Resistance measuring range is 40 mega with a resolution 0.1 Ohm. The Capacitance range is upto 4.000 mF with a resolution of 0.001 nF. It also has Diode & Continuity test function. It can measure Frequency upto 10MHz with resolution 0.01Hz. It also has Temperature measurement function with K-type Thermocouple having range upto 1000 degree C. The Thermocouple supplied along with the clampmeter is suitable upto 250 degree C. Additionally it has Non-Contact Voltage Detection function. The Jaw opening is 28mm diameter. Over load input signal is displayed by “OL”. If there is no operation of any function switch or any button for 15 minutes the instrument will be automatically power off. It is light in weight (approximately 248g including batteries). The clampmeter is supplied with Test lead, Battery, User Manual, K-Type Temperature Probe range upto 250 degree C & Carrying case. Optionally, thermocouple upto 1000 degree C can be supplied.



Contact :

**Kusam Electrical Industries Ltd.**  
 Shop No.18, 1st Floor, CIDCO Shopping Complex, Plot # 9  
 Sector-7, Rajiv Gandhi Marg, Sanpada, Navi Mumbai 400 705  
 ☎ 022 – 2775 4546, 2775 0662, 2775 0292  
 E-mail: [sales@kusam-meco.co.in](mailto:sales@kusam-meco.co.in)

## Specialized Cables

Chandresh Cables Ltd is an ISO 9001: 14001 Company and is a leading Cables and Wires manufacturer of high quality HT/LT PVC/XLPE, Aluminium/Copper, Unarmored/Armored, Industrial Control and Power Cables. The Company supplies Specialized Cables such as Fire Survival Cables; Flat Submersible Cables; Rubber Cables; Instrumentation Cables; Aerial Bunched Cables, Solar Cables, etc.

Contact:

**Chandresh Cables Ltd**  
 G-6 New Madhavpura Market  
 Nr: Police Commissioner Office  
 Sahibaug, Ahmedabad, Gujarat 380 004  
 ☎ 079 – 2562 3055, 2562 3056 • E-mail: [info@avocab.com](mailto:info@avocab.com)

**Internal (Bore) Grinding Machine** ▶

Models Available:  
 HIUC-150, HIUC-300,  
 HIUC-450, HIUC-500 &  
 HIUC-600



**Cylindrical Grinding Machine** ▶

(Manually/Electrically/ Hydraulically)

Models Available: UC-150, UC-300,  
 UC-450, UC-500, UC-600, UC-800,  
 UC-1000, UC-1250, UC-1500,  
 UC-2000, UC-2500, UC-3000



**Centreless Grinding Machine** ▶

(Manually & Hydraulically)

Models Available:  
 DG-50, DG-75, DG-100



**DEVCO INDUSTRIES**

157, G.I.D.C. Ambawadi, Phase II,  
 Wadhwan City-363 035. (Gujarat)  
 Ph : 02752-243997  
 Mobile : 93744 12368  
 E-mail : [devco1980@yahoo.com](mailto:devco1980@yahoo.com)  
 Web : [www.devcogrinders.com](http://www.devcogrinders.com)





A Trusted Name In Cables

**Empire<sup>®</sup>**  
**CABLES**

AN ISO 9001 : 2000 CERTIFIED COMPANY

**ACRAB CAB**  
Wires & Cables



## Total Cables Solutions

IS:694  
  
IS:1554  
IS:7098  
IS : 14255



### PRODUCT RANGE :

- Power & Control Cables (Aluminium/Copper Conductor/Armoured Unarmoured Cables)
- FR / FRLS / PVC Cables. (HT & LT Cable)
- House Wiring / Multicore
- Flexible / Industrial Cables,
- Hook-up Wires.
- 3 Core Flat Submersible Cables.
- Telecommunication Cables.
- Co-axial / Instrumentation/ Computer Cables.
- Aerial Bunched Cables.
- TRS / TRS Braided / Welding Cables.
- CCT / Cat-5 / LAN Cables.
- Solar Cables.
- Moulded Plugs.
- All Kinds of Other Special Cables

## PVC INSULATED INDUSTRIAL WIRES & CABLES

Aerial Bunch Cable ABC upto 11 Kv.

Mfg. By :  
**EMPIRE CABLE INDUSTRIES PVT. LTD.**  
115, Phase - II, Badli Industrial Area, Delhi - 110042  
Tel. : 011-27854325 Mob. : 9990047711, 9810047711

Mktd. By :  
**RAGHAV CABLES PVT. LTD.**  
1853, Surya Bazar, Bhagirath Palace, Delhi-6  
Tel. : 011-2386 8832, 2386 7957, 2387 4632

Dubai Off. :  
**POWER EMPIRE WIRES & CABLES TRADING COMPANY LLC**  
Shop No. 13/1, Al Jaziri Building, Al Nakhal Street, Deira, DUBAI (U.A.E.)  
Tel. : +971 - 582524031, 585870199 M.: +91 98116 47711

✉ [empirecables@yahoo.co.in](mailto:empirecables@yahoo.co.in), [sales@empirecables.com](mailto:sales@empirecables.com)

🌐 [www.empirecables.in](http://www.empirecables.in) | [www.acrabcab.com](http://www.acrabcab.com)

**DEALERS DISTRIBUTORS ENQUIRY SOLICITED**

## Accelerating Design with Solutions

Success in manufacturing is determined by the fact that how much less time we will take to deliver our product to our customer. Coupled with the lower rejection and field failures will help the company to gain major market share. In this context, Kadkraft Systems Pvt Ltd a 30 year old company provides globally proven solution to help the Indian industries to succeed in the market. Leading companies like Shanthy Gears, Premium Transmission, Kirloskar, Elecon, Vulcan, Tata Motors, Daimler, Mahindra, Bajaj Auto and many other have been using KISSsoft and KISSsys successfully for past several years. KISSsoft - India's most popular gearbox design



software from Switzerland is being widely used by leading automotive and industrial gearbox companies. KISSsoft covers all common gear types, shafts, bearings, shaft-hub connections, bolts, springs etc. It is used for the analysis of a single element and to design complex transmissions and drive trains. The software does the geometry and strength calculation based on ISO/DIN/AGMA and other standards for the machine elements. The software can help you to increase torque carrying capacity at minimal costs, selection of the right bearing, micro-geometry modifications and export of accurate 3D gear models for rapid prototyping and 3D printing. 3D scanner is the latest industry trend used for reverse engineering and quality inspection. SMARTTECH3D offers world's highest resolution colour and mono scanners of 24 Mpixel and 20-20 Mpixel stereo scanners respectively. High resolution scan can capture minute details for detailed scanning for reverse engineering and quality inspection. It works with software like Measure, Polyworks and Verisurf. The scanners have some unique features including projection of deviation map on the part, 300 kg part automated rotary table, etc. The scanners are VDI 2634 certified to guarantee the scanning accuracy. It can scan with different Field of View with accuracy of 10 and 17 microns. Leading companies like GE, Volvo, Bosch, Adidas, US Army, Boeing and NASA etc. are using SMARTTECH scanners to design their products.

Contact:

**Kadkraft Systems Pvt Ltd**  
D-133B, Phase 7, Industrial Area, Mohali, Punjab 160 055  
Mob: 98143 62601, 98140 21311  
E-mail: [contact@kadkraft.com](mailto:contact@kadkraft.com)

**Subscribe to  
Industrial Products Source  
at ₹550/- for 2-year.**

## Vibratory Finishing Machine

S.M. Systems manufactures Vibro finishing process involves rubbing of parts to be finished with suitable media (ceramic, plastic, steel, etc) in presence of finishing com-



ound for pre-determined time. VIBRO-FIN vibratory finishing machine has a bowl that holds parts, media, water & finishing compound. The special vibratory motor mounted at C.G. of the system generates intense spiral motion of parts and media in the bowl. The relative motion between parts and media results in deburring, descaling, polishing etc. VIBRO-FIN vibratory finishing machine has different options for separation of parts from media. The bowl has hot cast polyurethane lining or natural rubber lining, drain for discharge of used compound & water. VIBRO-FIN vibratory finishing machine is available in wide range of capacities from 25 lits to 2500 lits. These machines are used when inbuilt separation is not required or it is not possible due to near size of the parts and media. In these machines at the end of the process time parts are picked up manually from the bowl. It is generally preferred when strong vibration intensity is required and for medium to big size parts or for heavy parts.

Contact:

**S.M. Systems Pvt Ltd**  
A-297, Road No.16-Z  
Wagle Industrial Estate, Thane West, Maharashtra 400 604  
Mob: 87670 58666 • E-mail: [sales@smssystemsin](mailto:sales@smssystemsin)

## Robotic Welding

Welding being a cumbersome process achieving higher productivity manually is a major task. With the robot the industry obtained the flexibility and mass production along with quality, productivity and consistency. Robotic automation can adapt to majority all welding technologies. Keepsake provides turnkey solutions for users welding automation requirements. The Company provides welding cells of: Metal Inert Gas (MIG); Tungsten Inert Gas (TIG); Plasma Transfer Arc Welding (PTAW); Laser Welding; and Laser Cladding.



Contact:

**Keepsake Automation LLP**  
1<sup>st</sup> Floor, Keepsake Welding Research &  
Skill Development Centre, LD College of Engineering  
Campus, University Road, Ahmedabad, Gujarat 380 015  
☎ 079 - 2630 7567 • E-mail: [info@keepsakeautomation.com](mailto:info@keepsakeautomation.com)





# PRAGATI GEARS



*Driven by passion*



Hydraulic Pumps



Starter Motor Shafts



Transmission Gears



Industrial Gear Boxes



Power Tools



Defence & Aerospace



Machine Tools



Worm & Worm Wheel



Spiral Bevel Gears



Sprockets

TYPES OF GEARS	RANGE					ACCURACY CLASS
	MODULE		DIAMETER(mm)			
	MINIMUM	MAXIMUM	MINIMUM	MAXIMUM		
SPUR	0.3	8	10	400	DIN 4	
HELICAL	0.3	8	10	400	DIN 4	
SPIRAL BEVEL	0.5	6.5	20	300	DIN 5	
WORM SHAFT	0.5	4	15	100	DIN 6	
WORM WHEEL	0.5	8	30	400	DIN 8	



Ratchets

## Pragati Transmission Private Limited,

No.531, 10th Main, 4th Cross, 4th Phase, Peenya Industrial Area, Bangalore - 560 058  
Email: kadam@pragatigears.com, mktg@pragatigears.com, pragatigears@rediffmail.com  
Tel: 080 - 2836 5364 / 2836 5352 • Mob: 93412 15974 / 70266 18881

[www.pragatigears.com](http://www.pragatigears.com)

## Cylindrical Grinding Machine

DEVCO Model UC-150 Cylindrical Grinder Machine manufactured by DEVCO Industries is available in different models. Its features are: Castings are close grained and well ribbed, minimize vibration and distortion; Wheel head spindle runs in bearings; Work head spindle runs in taper roller bearings; Tail stock, Wheel head and Work head spindle are heat treated to achieve dimensional stability; and performance roundness < 0.005 mm. Optional accessories offered are: Internal grinding attachment, two, and three point steady rests, wheel balancing stand, balancing arbor and wheel flange. Specifications – Distance between centres: 160 mm; Height of centre: 102 mm; Swiveling angle:  $\pm 9^\circ$ ; Traverse speed: 140-260-370-700 mm/min; Infeed of hand wheel: 0.01 div.; Grinding wheel size (d x w x b): 250 x 25 x 76.2 mm; Grinding wheel speed: 2300 rpm; Work head spindle speed: 90-210-360 rpm (three range); and Spindle in taper MT-3.



Contact:

**DEVCO Industries**  
**GIDC Phase-2, Plot No: 157, Wadhwan City**  
**Dist: Surendranagar, Gujarat 363 035**  
**☎ 02752 – 243 997 • E-mail: devco1980@yahoo.com**

## Built-in Cylinder Power Collet Chucks

The Jaws Manufacturing Co introduces its latest product – Air/Hydro Rotary Power Chucks with built-in cylinder. The Power Chuck is specially designed to help users to set up a power workholding system in a low cost way. With a built-in cylinder, it allows users to easily and quickly set up a power work-holding system. The system saves the cost of cylinder mounting flanges, draw bar/tube and connector. This Power Chuck also has quick-change jaw/collet design, helping you to cope with parts of various dimensions. The Power Chuck comes with both air and hydraulic models that range from small sizes to large ones, giving users more options to choose from. It can be applied to convert manual lathes to semi-auto ones with power workholding system, or can be applied to build all kinds of special purpose machines.



Contact:

**The Jaws Manufacturing Co**  
**103 Ramtekdi Industrial Estate, Hadapsar**  
**Pune, Maharashtra 411 013**  
**Mob: 91588 66112, 91588 66113, 91588 66114**  
**E-mail: jawssales@jawsindia.com**

## Low Profile Ratchet Type THL Series

Constrained spaces with high torqueing requirements call for Hydraulic Torque Wrenches which have a Lower Profile with Tritorc's Hex Drive THL series; you can harness

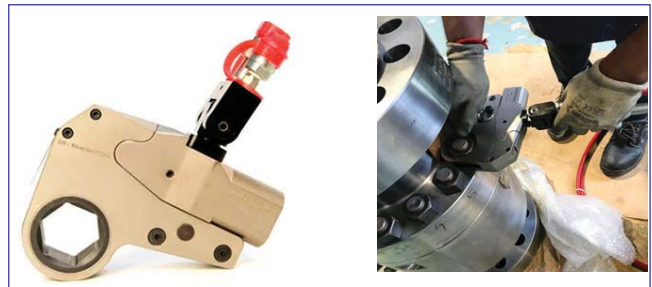

a tool with the following advantages: High nickel alloy steel internal components ensure long-lasting moving parts. The rod engages in the first stroke thus removing any backlash. The Hydraulic Torque Wrenches use an Alloy steel high-strength hydraulic cylinder designed to exert torque as per the application. The ratchet and pawl have a finer tooth for better engagement and torqueing. The quick connectors for the hydraulic lines are leak-resistant for safety even under pressure. This is an industry-standard feature of the Tritorc hydraulic Torque wrench. The low profile of the Hex-type torque wrench allows the tool to fit the narrowest gaps. Technical Specification: Minimum Torque: 293 Nm (214 Ft. Lbs.); Maximum Torque: 53512 Nm (38875 Ft. Lbs.); Drive Unit Minimum Weight: 1 Kgs (2.2 Lbs.); Drive Unit Maximum Weight: 11.4 Kgs: (25.3 Lbs.); Ratchet Unit Minimum Weight: 1.6 Kgs (3.5 Lbs.); Ratchet Unit Maximum Weight: 30 Kgs (66 Lbs.); Maximum Pressure: 70 Bar (1000 PSI); Minimum Pressure: 700 Bar (10000 PSI); Bolt Sizes Serviced Range from: M 19 to M 175; and Number of Tool Models: 5.

Contact:

**Tritorc Equipments Pvt Ltd**  
**Kripam House, Plot No: A-158, Road No. 25**  
**Wagle Industrial Estate, Thane, Maharashtra 400 604**  
**☎ 022 - 4126 6028 • Mob: 84337 08957**  
**E-mail: response@tritorc.com, marketing@tritorc.com**

## Polyester Woven Lashings

Multitech Products Pvt Ltd, an ISO Certified Company offers Polyester Woven Lashings, which are available in sizes of 25, 32, 40 and 50 mm, and in various strength as per customer requirement. Ratchet assembly with J hook with 1 T to 5 T capacities. The Company is a leading manufacturer of Corded Polyester Composite Strap and Wire Buckles. Their Products range includes: Du8nnage Air Bags, Silica Gels, Clay Desiccant, Heavy Duty Desiccant, Tensioners, Trolley, KT Cargo Bars, etc.

Contact:

**Multitech Products Pvt Ltd**  
**A/P- Kasar Amboli, Tal: Mulshi**  
**Dist: Pune, Maharashtra 412 115**  
**Mob: 95958 45499, 98226 11935**  
**E-mail: sales@multitechdesiccant.com**

## Centrifugal Finishing Machine

S.M. Systems manufactures SUPER FIN centrifugal finishing is a unique high energy mass finishing process. In this machine four barrels are mounted on the periphery of the



roating turret. As turret roates along its axis at high speed, centrifugal force is generated inside the barrels. These barrels are also rotated along its own axis (straight axis or skew axis) in opposite direction. Each barrel contains media, finishing compound, water and parts to be finished. Due to rotation of turret and barrel, media inside barrel rub against the parts under pressure. The high pressure sliding / rubbing action of media performs the surface finishing of the parts and reduces finishing time to just a few minutes from many hours. SUPER FIN is ideally suited for high quality finishing. It can process even fragile & delicate parts without any distortion. SUPER FIN with Removable Barrels In this type of SUPER FIN barrels are of detachable type. Barrels are removed from the machine for loading & unloading of parts and media. By keeping one set of spare barrels, the idle time of machine during unloading / loading can minimized and so the output from the machine can be maximized. The barrel rotation axis can be straight or skew as per requirement of the process. Turret & barrel rotation speed (RPM) and can be made variable by incorporating VSD (variable Speed Drive). The machine is provided with manual sorting table for part media separation.

Contact:

**S.M. Systems Pvt Ltd**  
A-297, Road No.16-Z  
Wagle Industrial Estate  
Thane West, Maharashtra 400 604  
Mob: 87670 58666 • E-mail: sales@smsystems.in

## Relays & Relay Modules

Salzer offers AC and DC Relays from 3 to 80 Amps from 1 to 4 pole; DC power relays up to 125 Amps; Silver contacts for enhanced electrical life; Miniature, General purpose, Power and Automotive Relays; Termination via solder, PCB mounted, Plug-in and Screw type terminals; ERDA tested and complies with JSS standards; Relay Modules: 1 and 2 changeovers with 2, 4, 6 and 8 channels.

Contact:

**Salzer Electronics Limited**  
Samichettipalayam, Coimbatore, Tamil Nadu 641 047  
☎ 0422 - 423 3600 • Fax: 0422 - 269 2170  
E-mail: salzer@salzergroup.com



# V.V.MUJUMDAR & ASSOCIATES

AN ISO 9001-2008 Certified Co.



## FLEXIBLE COUPLINGS For CNC Machines, Encoders



## PRECISION LOCKNUTS For Ballscrews, Spindles



## ROLLED BALL SCREWS

From dia 16mm-80mm • Length upto 6 Mtrs standard  
For SPMS, Automation, Robotics, Material Handling

We also undertake Repaires & Servicing of Ballscrews

Plot No. T-165/1/25, Priyadarshini Co-Operative  
Industrial Society, Near Post Office, MIDC, Bhosari,  
Pune - 411 026, Maharashtra

Telefax : 020 - 27129820

Mobile : 9766626745

Email : vvmujumdar@gmail.com

Web : www.vvmujumdar.com

## Valves And Solenoid Valves Series EN

Camozzi India provides Valves and Solenoid Valves Series EN. The Company has developed a new Series of valves to be used in applications requiring a reduced space of installation and in situations where the valves need to be located as near as possible to the operating elements. The single valves can be mounted on any flat surface, allowing compact machine design, which is also enhanced by the reduced dimensions of the valve itself. This new generation of solenoid valves is the evolution of the previous Series E, size 16 - 19 mm valve with ports threaded into the body. As this valve is completely interchangeable with Series E, part of the code is maintained though the valve has a completely new shape and new components. The company firmly believes that competitive forces are the best motivation for innovation, company growth and product development, and that under such conditions the best results ensue. Camozzi India has developed a culture of innovation and a continuous process of improvement in its production capability, which has resulted in closer customer relationships.

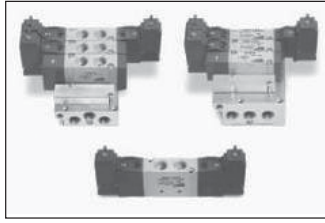

Contact:

**Camozzi India Private Limited**  
D-44, Hosiery Complex, Phase-2 Extension  
Gautam Budh Nagar, Noida, Uttar Pradesh 201 305  
☎ 0120 - 405 5262, 405 5200  
E-mail: [c\\_application@camozzi-india.com](mailto:c_application@camozzi-india.com)

## Cable Drag Chains

Elektromag offers a wide range of metallic/plastic Cable Drag Chains. Features: these cable drag chains enable the conveyance of flexible cables/hoses, etc. to movable units with maximum reliability; its advantages are avoidance of mechanical strain on the cables/hoses; and no tensile stress or compression, no frictional wear as there is no relative movement between the cables/hoses and the cable drag chain, no bending below an established radius, no crushing, buckling or forming of loops or torsion strain. The company started in 1958, is engaged in manufacturing of metallic/plastic cable drag chains and supplying to various steel plants, machine tools, cement, foundries, etc.



Contact:

**Elektromag Methods**  
307 Prabhadevi Industry, Dadar West  
SVS Road, Prabhadevi, Mumbai 400 028  
Mob: 98201 92772 • E-mail: [cablereels@elektromag.com](mailto:cablereels@elektromag.com)

## Digital Multimeter, Model - KM 60-T

KUSAM-MECO has introduced a new TRMS Digital Multimeter Model-KM 60-T. It is a 6000 counts Multimeter having 12 functions and 39 ranges. It has a large back-light display. It measures TRMS AC Voltage up to 750 V and AC Current up to 10 A. It has function of DC Voltage up to 1000 V and DC Current up to 10 A. It can also measure frequency up to 10 MHz. The Resistance range is up to 40 MOhms. Additionally it measures Capacitance upto 9.999 mF. It also has Diode and Continuity Test. Other features include: Non-Contact Voltage detection and pulse output. It also has data hold and MAX/MIN and Rel Zero functions. For taking measurement in poorly lit or dark places, it is equipped with a flash light.



To conserve power, the instrument will be deactivated if there is no input signal for about 15 minutes. Over range is displayed by "OL". It is light in weight (approx. 250 g including battery), is supplied with high quality Test lead, battery and user manual, and is warranted for one year.

Contact :

**Kusam Electrical Industries Ltd**  
G-17, Bharat Industrial Estate, T J Road  
Sewree (W), Mumbai 400 015  
☎ 022- 2415 6638, 2775 4546, 2412 4540  
E-mail: [sales@kusam-meco.co.in](mailto:sales@kusam-meco.co.in)

## Digital Time Switches Crono® & Plus

General Industrial Controls Private Limited offers Digital Time Switches Crono® & Plus. Features are: precise time programming for daily/weekly/pulse switching; 25 ON/OFF programs; weekend exclusion (FRI SAT or SAT SUN) and weekly OFF programming; LED indication of relay status; 12/24 hour display formats; 6 years battery reserve; simple reset and manual override; settable DST and keypad lock feature. The company established in 1972, is one of India's leading manufacturers of process control, automation and instrumentation products.



Contact:

**General Industrial Controls Private Limited (GIC)**  
T-107, MIDC Road, T-Block, MIDC  
Bhosari, Pune, Maharashtra 411 026  
☎ 020 - 4623 2323 • E-mail: [sales@gicindia.com](mailto:sales@gicindia.com)

## Ceramic Bearings

Mac Marketing Corporation offers hybrid ceramic bearings as well as full ceramic bearings. The hybrid ceramic bearing comprises of chromium steel or stainless steel rings and ceramic balls whereas the complete or full ceramic bearing offers the rings to be in ceramic material, balls in ceramic material and cages to be ceramic compatible, such as PEEK or otherwise as requested by the customer. These bearings find numerous applications in machine tools like CNC machining centre, CNC grinding centre, CNC milling machine, swivelling machine and rotating articulation of robot arm and turbines, Medical equipment for producing vaccines and vaccination drugs and also can be used in

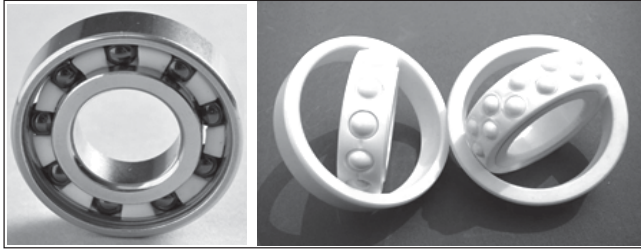

places with extreme temperatures both high and low. Zirconium oxide (ZrO<sub>2</sub>) and silicon nitride (Si<sub>3</sub>N<sub>4</sub>) are typical materials used in all the ceramic bearings. Both provide excellent corrosion and temperature resistance up to 1000° centigrade as well as other mechanical properties. Mac also offers ceramic balls only of various sizes and grades both Zirconium oxide and Silicon nitrate. Apart from ceramic balls we also offer balls in various materials such as stainless steel, plastic (various materials), glass, brass, bronze, aluminium, titanium and grinding balls and rubber balls etc., Mentioned below are the few advantages of a Ceramic Bearing: High chemical resistance; Corrosion resistance; Thermal Expansion; Non- magnetic and current insulation. MAC was established in the year 1987, engaged in the field of Rolling Bearings and allied products including Water Lubricated Bearings, Stainless Steel Bearings, Self-Lubricating Bearings, Slewing Ring Bearings, Ceramic Ball Bearings, Hydrostatic Bearings, Combined Bearings, Rod End Bearings, Wire Race Bearings, and many more, ranging from 1 mm dia up to 7000 mm dia including slew bearings in stacker reclaimer, mounting stations, etc., with an experience of more than 4 decades in the industry.

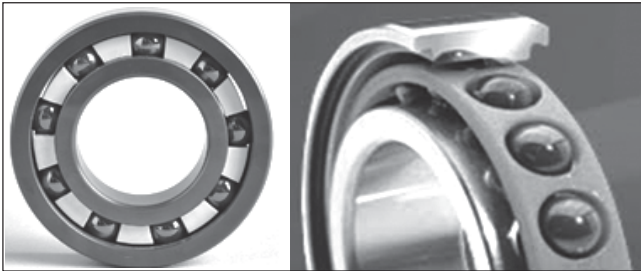

Contact:  
**Mac Marketing Corporation**  
 Mac Manor, 235 RMV, 5th Cross Road  
 2nd Stage, 2nd Block  
 Bengaluru, Karnataka 560 094  
 ☎ 080 – 2351 6096 • Mob: 98450 18280  
 E-mail: info@macmktg.com

## ALPHA Horizontal Bed Heavy Duty Precision CNC Lathe

SriYantra Engineers offers ALPHA Horizontal Bed Heavy Duty Precision CNC Lathe, which is provided with Rigid Cast Iron Legs/Bases, Alpha CNC lathes are robustly constructed for heavy duty applications. The lathes are available in Centre Heights ranging from 200 mm to 800 mm and Admit between Centres from 500 mm and 6000



mm. ALPHA CNC Lathes are Equipped with FANUC/Siemens/Mitsubishi CNC Systems, Ball Screw and Servo Motors for X and Z Axes, Variable Speed Spindle Drive through a Gearbox for High Torque at low RPM. With options of Manual/Hydraulic Chucking System, 4-way tool post/8 Station Turret, Manual/ Hydraulic Tailstock, Chip Conveyor etc., these machines offer Great flexibility and are suitable for batch production of a wide variety of components. Over 300 units of ALPHA CNC Lathes are installed across India. Sales and Service Support is available Pan India.

Contact:

**SriYantra Engineers (P) Ltd**  
 (Formerly: Sri Yantra Engineering Agencies (P) Ltd)  
 #362/A, 10th Cross, 4th Phase, Industrial Area  
 Peenya, Bangalore, Karnataka 560 058  
 ☎ 080 – 4071 0555  
 E-mail: info@sriyantra.co.in

★
● AMP - HOUR ● TEMPERATURE
★

### Digital Humidity Indicators / Controllers

**Basics**

- ▶ Direct, Accurate display of Humidity and Temperature
- ▶ Uses the classical Dry/Wet temperature sensing Technique
- ▶ Sensors are sealed Platinum PT100 type in S.S. immune to atmosphere gases etc.
- ▶ No need of any look-up table as the embedded software accesses the table from the micro controller memory.
- ▶ A sturdy sensor body has in-built water reservoir with facility to connect a water-drip to ensure the wick never dries up.
- ▶ 4 Control outputs for Humidifier, De-humidifier, Heater and Cooler.

HUMIDITY / TEMPERATURE LOGGER - RS232 MODEL No: 7210L



ALSO AVAILABLE USB DIRECT PEN DRIVE LOGGER



Mfd. by **COUNTRONICS** ISO 9001:2015 CERT

3/1/29, Sahibabad Industrial Area  
 Site - IV, Ghaziabad, Uttar Pradesh 201 010  
 Mob: 098105 36887 / 098183 50088  
 E-mail: countronindia@gmail.com  
 Sister Firm: Audiotronics • Website: www.countronics.com

★
EXPORT QUALITY PROCESS CONTROL INSTRUMENTS
★

## Aircrafts Components

Meru Precision Industries offers Aerospace Components for aircrafts, which are manufactured utilizing quality materials and exactness building procedures. Features are: Submit to global quality models and offer these products with superb execution, ero-

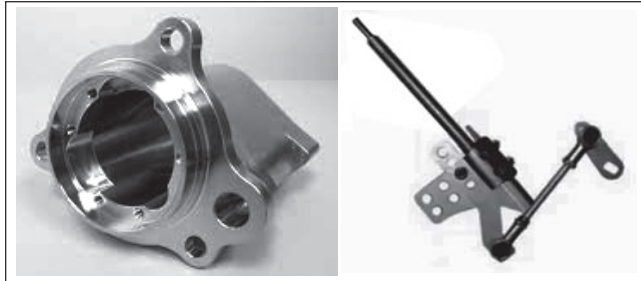

sion safety and more administration life characteristics; and according to the particular prerequisites. The company is engaged in the manufacturing, supplying, and exporting of industrial gauges, aerospace components, jigs and fix-

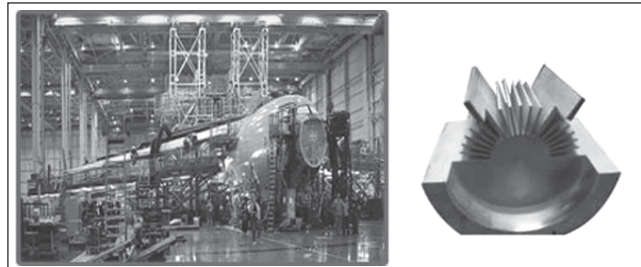

tures, industrial gearboxes, special purpose machines, instrument boxes, lead screw nuts, and splitting machines.

Contact:

**Meru Precision Industries**  
1706, Dr Rajkumar Road, Prakash Nagar  
Rajajinagar, Bengaluru, Karnataka 560 021  
☎ 080 – 2332 4085, 2328 4708 • Fax: 080 – 2352 5559  
Mob: 99864 65377, 96202 23786  
E-mail: merushiv@yahoo.com

## Flexible Couplings/Precision Locknuts/ Rolled Ball Screws

V V Mujumdar & Associates, an ISO 9001-2008 Certified Co offers Flexible Couplings for CNC Machines, and Encoders; Precision Locknuts for Ball Screws, and Spindles; Rolled Ball Screws from dia 16-80 mm; Length up to 6 m Standard for SPMS, Automation, Robotics, and Material handling. The Company also undertakes Repaires and Servicing of Ballscrews.

Contact:

**V V Mujumdar & Associates**  
Plot No: T-165/1/25, Priyadarshini Co-op Industrial Society  
Nr: Post Office, MIDC, Bhosari, Pune, Maharashtra 411 026  
Telefax: 020 – 2712 9820 • Mob: 97666 26745  
E-mail: vvmujumdar@gmail.com

## Surface Plates with Bench Centre & Box Angle Plate

Sanjeev Precision Technologies offers Surface Plates with Bench Centre, and Box Angle Plate. The Surface Plates with Bench Centre (Pix, top) equipment can be used as a Precision Inspection Bench Center as well as a Surface Plate (two-in-one) with high Grade of accuracy. Granite surface plate with metal inserts and T-Slot can be used as a surface Table and a concentricity checking attachment. The Cast



Iron Box Angle Plate to Grade 1 and Grade 2 accuracy is as per IS: 2632. These are basically used for clamping work for tooling, shaping and milling, wherein, job can be fixed on one of its faces and are rotated in 5 positions without the need of repositioning or disturbing accuracy. The Company's other products range includes: Comparator Stand, Cast Iron Bench Centre, Granite Master Squares, Granite Straight Edges, etc.

Contact:

**Sanjeev Precision Technologies**  
4144 Mathur MMDA, Manali, Chennai 600 068  
Mob: 90929 19797, 81299 26287  
E-mail: sptchennai@gmail.com

## Level Adjusting Caster Wheels

Jyoti Architectural Products offers Level Adjusting Caster Wheels. Features are: these level adjusting caster wheels

are now available from ready stock with load capacity 50kg/250/500 / 750 & 1000kg/ wheel unique design allows to move the equipment on wheels whenever required; after positioning at desired place it will rest on rubber pad; and this will eliminate movement and



vibrations of equipment. The company started in 1992 is the prominent manufacturer, suppliers, importers, traders and exporters of caster wheels and furniture components. Being appreciated for their optimum quality, perfect finish and dimensional accuracy, their products are highly demanded in residential as well as commercial application by interior designers and architects.

Contact:

**Jyoti Architectural Products Pvt Ltd**  
A-111, Sagar Tech Plaza, Andheri Kurla Road, Sakinaka  
Andheri East, Mumbai 400 072  
☎ 022 – 4242 1000 • Mob: 93208 92981  
E-mail: sales@jyotiarch.in

## Indication System to Monitor Conveyor Safety Switch Status

Belt Watch is a sophisticated 2 wire indication system to monitor conveyor safeties: Modern complex bulk material conveying systems contain a large number of belts hav-



ing considerable lengths, involving hundreds of safety switches. Checking out the actuated switch for rectifying and putting the system back into operation, therefore, becomes a long drawn out process resulting in huge production loss. While some relief was provided by indicating flags or lamps fitted on the individual switches, it was imperative to provide an arrangement to enable the operator in the remote control room to know immediately the location of the 'operated' switch. Jayashree Belt Watch is the sophisticated monitoring and indication system that is simple, cost effective and most importantly-highly reliable.

Contact:

**Jayashree Electrodevices Pvt Ltd**  
**W1, F-2 Block, MIDC, Pimpri**  
**Pune, Maharashtra 411 018**  
**☎ 020 - 4072 0021 • Fax: 020 - 4072 0026**  
**Mobile: 95525 86754 • E-mail: jedl.sales@jayashree.in**

## Taparia Carpenter Tools Jack Plane

Taparia launches Carpenter Tools Jack planes. Jack Planes are used for shaving off wood to reduce a piece to the desired smoothness and the general workhorses for stock removal. High-quality cast iron body with precision machined base, Carbon steel blade and Brass adjusting screw. Fine adjustment is controlled by adjusting screw; handle for



Impact-resistant and knob for comfort and control. They are well balanced, with a light-weight, ergonomic handle that makes gripping easy. Taparia's Jack planes are widely acknowledged in the market for their high performances and best Value for money qualities.

Contact:

**Taparia Tools Ltd**  
**423/424, A-2, Shah & Nahar**  
**Lower Parel (W), Mumbai 400 013**  
**☎ 022 - 6147 8646 • E-mail: htaparia@tapariatools.com**

## Slewing Bearings

Apex Renogear is a solution for middle size and heavy-duty slewing bearings. Renogear is part of the Xubi Group of Spain, a worldwide leader and a reference in mechanical transmission components.



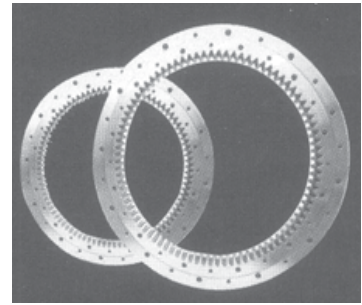











Renogear meets the highest quality demands and is, therefore, able to meet the current customer demands. Renogear produces slewing bearings up to 4.500 mm external diameter. Renogear offers a complete range of slewing bearings customized and adapted to the demands of the customer: single row ball bearing; double row ball bearings; cross roller bearings; three row roller bearings; and roller ball bearings. The gear teeth can be external and internal, both helix and straight. Renogear offers slewing bearings for many applications such as wind generators heavy-duty machinery, mining equipment, cranes or machine tools, among others.

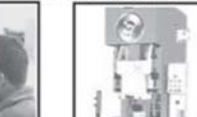

Contact:

**Apex Precision Agencies**  
**303-308 Krishna Bhuvan Annexe**  
**22-B Govandi Station Road, Deonar, Mumbai 400 088**  
**☎ 022 - 6146 4444 • Fax: 022 - 2556 4987**  
**E-mail: sales@apexprecision.co.in**

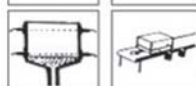
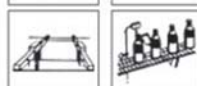
## SENSORS, SAFETY LIGHT CURTAIN, COUNTERS

 Inductive Proximity Switches	 Photoelectric Sensors	 Anti Crane Collision Sensor
 Infrared Sensors	 Large Display Counters	 Mini Infra Red Sensors
 Safety Light Curtains	 Two Hand Safety Device for Rolling Key Presses	 Safety Light Curtains
 Safety Light Curtains	 Safety Light Curtains	 Safety Light Curtains
 Safety Light Curtains	 Safety Light Curtains	 Safety Light Curtains



### Photon Controls (India) Pvt. Ltd

Plot No.C 10/1, Gala No.54, NICE INDL. ESTATE,  
 Ladies Proj. MIDC, Satpur, Nashik - 422 007.  
 Telefax: (0253) 2355498, 2352760 • Mob: 093739 07348  
 E-mail: photoncontro@gmail.com / mukund@photoncontrols.com  
 Website: www.photoncontrols.com



## Drop Point of Grease Apparatus (SICBDPG-01)

Shambhavi Impex offers Drop Point of Grease Apparatus. As per IP 31 the apparatus consists of Brass Sleeve and case with metal cup and a glass Boiling tube with Cork fitted to a bath 600 ml beaker is provided. The assembly is kept on heater with energy Regulator control and stand with FHP electric Stirrer. As per IP 132 the unit Comprises a glass beaker with fiber Cover together with glass test tube with three indentations to receive Chromium plated brass cup cork for tube and a 1.5 mm diameter Brass rod. The assembly is kept on heater with energy regulator and stand with FHP motor stirrer. Drop point Apparatus as per IP 132 and ASTM D 566. Drop point Apparatus as per IP 31. Salient features: optional accessories; IP 40C low range thermometer; IP 41C high range thermometer; and IP 62C drop point special thermometer. The company was established in the year 2003, started exporting laboratory and scientific equipment, and over the years their products range has grown and today covers more than 2500 products.



Contact:

**Shambhavi Impex**  
108 Neco Chamber, 1st Floor, Plot No: 48  
Sector 11, CBD Belapur, Navi Mumbai 400 614  
Mob: 98208 68723, 80489 54982  
E-mail: info@shambhaviimpex.com

## Rotary Limit Switch for Cranes

Crane Control Equipments, supplies Rotary Limit Switch for Cranes. Features are: Its function is to stop the mechanism or drive at the extreme forward or reverse position. This is particularly suitable for the use on reversing drives such as hoists, and winches and also in rolling mechanisms that are used in steel plants such as coke ovens, feeding machinery and valve drives; the rotary limit switch consists of heavy-duty worm gear drive with a ratio of 48:1 or 60:1, which is built in a sturdy cast aluminium housing fitted on the main body of the limit switch and covered with dust tight gasket in cast aluminium enclosure. The company offers products like counter weight limit switch, radio remote control, master controller, etc.

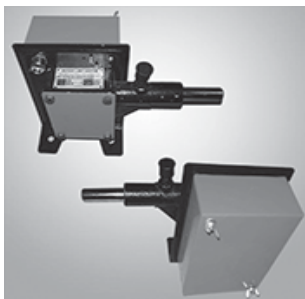

Contact:

**Crane Control Equipments**  
B-249, Okhla Industries Area, Phase-I, New Delhi 110 020  
☎ 011 – 4101 6403 • Mob: 93100 09466  
E-mail: info@cranecontrolequipments.com

## Driver Gloves

Vinit Gloven Manufacturing Pvt Ltd offers Driver Gloves. The features are: it is available from an exclusive range of driver gloves that are made from premium quality leather and are meant to be used while driving as well as handling the equipment; they are designed to protect all ranges of wrists and lower arms; they are available in different sizes and shapes to perfectly match any requirement; it is a cow grain glove; straight thumb and tape binding. The company is an ultra-standards entity; their products and processes not only adhere to industry standards like ISO 9001:2008 and SA 8000 but are actually way more efficient. All their operations are sustainable, eco-friendly, and pro-life.



Contact:

**Vinit Gloven Manufacturing Pvt Ltd**  
3, Pagladanga Road, Tangra P 42  
Udayan Industrial Estate  
Kolkata, West Bengal 700 015  
☎ 033 – 2323 4400 • E-mail: info@vinitgloves.com

## Rotary Air Lock Valves

Maxtech Engineer offers Rotary Air Lock Valves. Its features are: these valves are employed for vacuum/pressure looking to discharge continuous flow of materials. It is offered in CI/steel/stainless steel material; rotary valves are designed to provide improved performance to bulk material processing and production operations; rotary feeders, also known as rotary airlocks or rotary valves, are commonly used in industrial and agricultural applications as a component in a bulk or specialty material handling system. Rotary feeders are primarily used for discharge of bulk solid material from hoppers/bins, receivers, and cyclones into a pressure or vacuum-driven pneumatic conveying system. The company is a manufacturer of industrial pollution control equipment.

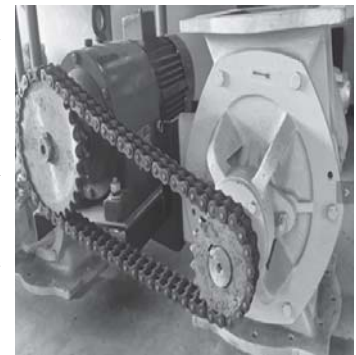

Contact:

**Maxtech Engineers**  
Plot No. 22, Tribhuvan Industrial Estate, Kathwada G.I.D.C  
Opp. Road No. 8, Ahmedabad, Gujarat 382 430  
☎ 079 – 2290 0657 • Mob: 98797 56789, 98250 16718  
E-mail: info@maxtechengineers.com



## Pressure Transmitters

Instruments And Systems offers Pressure Transmitters. The features are: the ISP 200 series offers combined linear repeatability and hysteresis errors that are typically below 0.2 to 1.5% FS of full scale, for high and low pressure measurement, gage and absolute; this circuit provides temperature compensation for a stable output through use of computer-controlled laser trimming of hybrid circuit component; some promising specifications include those of zero and span adjusted; long term stability; operating temperature range 40 to 125 deg C /- 0.25%; and electromagnetic interference [EMI] protection. The company, established in 1985, is engaged as a manufacturer and exporter of a range of measuring instruments and valves that are used in a number of industrial applications.



Contact:

**Instruments And Systems**  
**30, Industrial Area, Mohabbewala**  
**Dehradun, Uttarakhand 248 002**  
**☎ 0135 – 2641 580 • Mob: 94129 92347**  
**E-mail: info@instruments-systems.com**  
**info@instruments-systems.in**

## Highly Efficient IE4 Smooth Surface Motors

NORD Drivesystems offers a wide range of Highly Efficient IE4 Smooth Surface Motors. The advantages are as follows: the new permanent-magnet synchronous motors without cooling fins achieve level IE4 or super premium efficiency; the efficient smooth-surface motors are suitable for use in dry areas as well as in applications requiring frequent cleaning; because they generate very little excess heat, they do not require fans and thus do not contribute to the spread of germs; the IE4 or super premium efficiency synchronous motors operate with significantly more efficiency than the IE3 or standard efficiency synchronous motors. The company develops, produces, and sells drive technologies and is one of the international leaders in the industry. In addition to standard drives, NORD supplies application-specific concepts and solutions, even for special applications, such as energy-saving drives or explosion-protected systems.

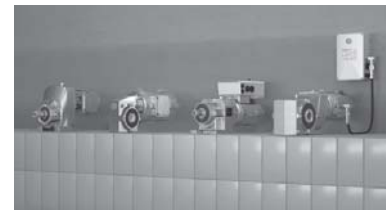

Contact:

**NORD Drivesystems Pvt Ltd**  
**No. 282/ 2 & 282/ 3, Village Mann, T. L. Mulshi**  
**A. D. J. Hinjewadi, M. I. D. C. 2**  
**Pune, Maharashtra 411 001**  
**Mob: 97654 90890 • Email: marketing.in@nord.com**

## Pneumatic Actuated Butterfly Valve

Ashok Vijay Engineering Works is offers Pneumatic Actuated Butterfly Valve. The features are: these valves are best-suited for areas that require regulated flow of fluids using a series of pipes. These valves are also used in larger lines in form of front as well as rear suctions as well as in fire apparatus based applications; the company is known for its expertise in making various dimensions and specifications including in customised finish options; they have applications in industry sectors such as petrochemical, gas, fertilizer plants, chemicals, refineries, power generation plants and others. It can also be customised. The company established in 1961, is a manufacturer, trader and supplier of qualitative array of piston valves, ball valves, ammonia valves, gate valves, check valves, globe valves, butterfly valves and forged valves.



Contact:

**Ashok Vijay Engineering Works**  
**Block No.-3, Abhay Sahakari Udhyog Nagar, Dudheshwar Road**  
**Shahibaug, Tavdipura, Ahmedabad, Gujarat 380 004**  
**☎ 079 – 2562 2238 • Mob: 90999 24050**  
**E-mail: ashokvijay12@rediffmail.com**

# FITZER

World Class Product Brand

PROCESS, MEASURING INSTRUMENTS & AUTOMATION

**PRESSURE**

- LIQUID COLOUR MANOMETERS
- DIGITAL MANOMETER
- DIGITAL PRESSURE GAUGES
- BAROMETER
- VACCUM MANOMETER
- PRESSURE SWITCHES

**FLOW**

- GLASS TUBE / ACRYLIC ROTAMETERS
- METAL TUBE ROTAMETER WITH TRANSMITTER / FLOW INDICATOR TOTALIZER
- BY-PASS ROTAMETER
- ELECTROMAGNETIC FLOWMETER
- FLOW SWITCHES
- AIR VELOCITY KIT

**LEVEL**

- LIQUID LEVEL INDICATORS
- LIQUID LEVEL TRANSMITTER
- LIQUID LEVEL SWITCHES (FLOAT OPERATED)
- CONDUCTIVITY LEVEL SWITCHES
- CAPACITANCE TYPE LEVEL TRANSMITTERS

**FITZER** INSTRUMENTS COMPANY (INDIA) Regd. Correspondence Address:  
 Atali, Near Ambivali Stn. (W), P.O. Mohone, Tal. Kalyan, Dist. Thane-421 102  
 Mobile: 8691816354 / 8691816355 / 8691816356 / 9426470248  
 E-mail: fitzerindia@hotmail.com / fitzergujarat@rediffmail.com

Dealership Enquiries Solicited
Website: www.fitzerindia.com

## High Voltage Transformers

Guru Nanak Electric Works offers a wide range of High Voltage Transformers. The features are: these voltage transformers are available as per requirements and specifications; manufactured from fine quality raw materials, this range of transformers is designed to withstand high load conditions; the transformers are suitable for high end requirements, supporting a wide variety of applications and offering trouble free service; they facilitate transmission of AC electric power or broken current from one circuit to a different circuit through electromagnetic stimulation; and features include high quality, low losses, and high durability. The company established in 1994, has emerged as a leader in manufacturing and export of a comprehensive range of electrical products. This includes high quality low-loss industrial distribution transformers, isolation transformers, voltage controllers, voltage regulators, etc.



Contact:

**Guru Nanak Electric Works**  
Oswal Agro Complex, Backside Oswal Woollen Mill  
G.T Road, Ludhiana, Punjab 141 003  
Mob: 98140 90227 • E-mail: gnew\_avtar@sify.com

## Rollers for Machine Movement

KGK Engineering offers Rollers for Machine Movement. The features are: easy-roll machine movement rollers (EZR-7) is a cost effective, time-saving, and maintenance free solution for smooth and damaged surfaces -free manual movement of machines and loads of all sizes and shapes, (e.g., weldments, castings, containers, bulky crates, etc.);

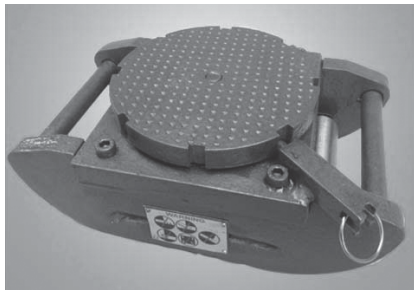

The easy-roll rollers allow machines and loads to be moved to locations on the shop floor that are not accessible by overhead cranes; once the load is placed on the rollers, it can be pushed or pulled manually or by a forklift or tractor; the rollers have a swivel attachment to negotiate turns; and each roller can take a load of 7 metric tons. The EZR-7 easy-roll roller kit comes as a set of 4 rollers and 2 steering handles. The company was established in 2014 out of a passion for designing and manufacturing.

Contact:

**KGK Engineering**  
No 36, BTM Phase 1, Phase 2, Electronic City  
Bengaluru, Karnataka 560 100  
Mob: 70223 75473 • E-mail: info@kgkengineering.com

## Pneumatic Grippers

Vihan Pneumatics & Hydraulics offers a wide range of Pneumatic Grippers. The features are: to cater to the diverse demands of customers in an efficient manner, these grippers are available in different grades and dimensions; the products are offered at market leading prices, these grippers are popular among regular users. Furthermore, they are delivered on time; and their features include high torque resistance capacity, corrosion resistance, and minimal maintenance. The company was established in 2015 and is a recognised trader, distributor, and supplier of pneumatic products. The range includes: pneumatic cylinders, pneumatic fittings, pneumatic units, pneumatic distributors, hydro-pneumatic cylinders, vacuum cartridges, suction cups, level compensators, solenoid valves, pneumatic accessories, pneumatic vacuum products, pneumatic tubes, pneumatic actuators, etc.

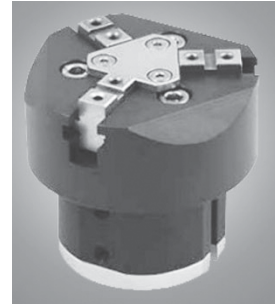

Contact:

**Vihan Pneumatics & Hydraulics**  
E-87, Mahaveer Industrial Park, B/h. Shankheshwar Park-2  
Opp. Midco Industries, Nr. Vatva Rly. Bridge, GIDC Vatva  
Ahmedabad, Gujarat 382 445  
Mob: 98790 62643, 84013 54609  
E-mail: vihanairwork@gmail.com

## Nickel Flanges

Horizon Mercantile Associates offers Nickel Flanges. The features are: these flanges are known for their stability, are manufactured using best quality materials with international quality standards; available in a wide range of shapes and sizes in accordance with and suitable for a variety of industrial requirements. The company, established in 2007, is engaged in the manufacturing and exporting of a range of metal products, including, hastelloy C22/C276, nickel 200/201 products, monel 400/K500, alloy 20, titanium, inconel 600/625, duplex steel, alloy steel, and various others. These products are manufactured from high grade stainless steel, nickel, and other metal alloys using sophisticated technology.



Contact:

**Horizon Mercantile Associates Pvt Ltd**  
Plot No. 2, Ground Floor, Shashi Kripa Bldg., Pawala Street  
Raja Ram Mohan Roy Road, Mumbai 400 004  
☎ 022 – 2385 5158, 2385 5159  
Mob: 98196 79707, 91672 50453  
E-mail: info@horizontrade.in, sales@hmagroup.in

## Cut Gaskets, Non Metallic

Citizen Metals offers a wide range of Non-Metallic Cut Gaskets. The features are: these products use high grade raw materials such as CAF sheets, insulation sheets, graphite, thermoplastics, non-asbestos sheet material, non-asbestos mill-board, and glass fibre; the range encompasses cut gaskets, heat shields, beater addition sheets, washers, spacers, PTFE envelopes, and cork rubber sheets; and the range is procured from reliable vendors to ensure it is



developed at par with industry specifications. The company, founded in 1981, is engaged in the manufacturing and export of a varied range of industrial products. The range includes stainless steel, carbon steel, and alloy steel products. The products show unique attributes such as durability, high tensile strength, rust resistance, and sturdy construction and cater to the needs of diverse industries.

Contact:

**Citizen Metals Private Limited**  
Prasad Chambers, Office No. 912A, 9th Floor  
2022, Charni Road, Opera House, Mumbai, 400 004  
☎ 022 – 6190 5600 • Mob: 98194 48843  
E-mail: [exports@citizenmetals.com](mailto:exports@citizenmetals.com)

## Lithium – Ion Battery 152P

Hydax Hydraulics offers a wide range of Lithium – Ion Battery 152P. The features are as follows: these lithium-ion batteries (LIBs) are considered a pioneering technology that has been successfully adopted as a power source for a wide range of applications, including portable electronics, electric/hybrid electric vehicles (EVs/HEVs). The company was established in the year 1979, a technocrat with over 40 years of expertise behind him. The concept, right from the onset, was to create products that would be indigenously designed, technologically superior, and commercially viable.



Contact:

**Hydax Hydraulics Pvt. Ltd.**  
Plot No. 22B, Attibele Industrial Area,  
Anekal Taluk, Bangalore, Karnataka 562 107  
Mob: 99160 70034, 95134 99976  
E-mail: [sales@hydaxindia.com](mailto:sales@hydaxindia.com)

## Additive Manufacturing Services

Voestalpine High Performance Metals India offers Additive Manufacturing Services. Features: additive manufacturing adds to the range of products and services voestalpine can offer its customers and underscores the research capabilities of the group as well as its ability



as a manufacturer of premium metal powder, the starting point for first-rate 3D printing with metals; with the new technology, Voestalpine is using its capabilities to further advance additive manufacturing and is establishing additional research centers and production facilities for this purpose; specialists are on improvements to metal powders as well as on the design and production of metal components using the 3D printing process. The company is the Indian operation of Voestalpine AG, a leading technology and capital goods group. Based in Linz Austria, Voestalpine is a global partner to the automotive, white goods, and energy industries.

Contact:

**Voestalpine High Performance Metals India Pvt Ltd**  
A-409, Skylark, Sector 11, CBD Belapur  
Navi Mumbai 400 614  
☎ 022 – 2757 7441  
E-mail: [office.india@voestalpine.co.in](mailto:office.india@voestalpine.co.in)

## TECHNICALLY RELIABLE PRODUCTS

We Design Drives, Manufacture Pulleys In All Pitch For Timing Belts Hob Cut With Imported Cutters Conforming To International Standard, Special Vee Belt & Flat Belt Pulleys & Any Belt Pulley As Per Drawing.

We Deal in Imported:

- Timing Belts • Flat Tangential Belts • Wedge-space Saver Belts
- Nylon Sandwich Belts • Conveyor Belts • Poly 'V' Belts
- Endless Belts • Poly Flex Belts • Catter Pillar • Perlon Ropes & Any Special Belts are manufactured as per Client's Requirement.



**TRP**  
**kwedos**  
Belt Drives



B-2, Alaukik Flats, Near Dwarkesh Tower, Judges Bungalows Road,  
Bodakdev, Ahmedabad 380 015.  
Mobile : 99251 11749 • Telefax: 079 - 2687 0311  
E-mail: [sales@kwedos.com](mailto:sales@kwedos.com) / [info@kwedos.in](mailto:info@kwedos.in)

## Turrets

Secon offers wide range of high precision, high quality Turrets, both Hydraulic and Servo type. Turrets are carefully designed and manufactured by M/s. LIO-SHING Co. from Taiwan for present, fast and accurate positioning market. Hydraulic turrets are driven by hydraulic motor for high torque output and maximum stability. Hydraulic turrets clamping / Unclamping is operated through hydraulic Power hence assumes smooth motion and permits for heavy duty Machining. The company is engaged as a manufacturer, trader, service provider, distributor of CNC machine tools.

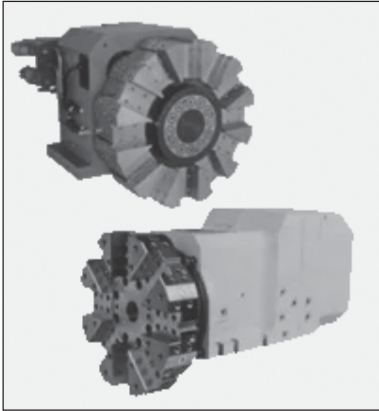

Contact:

**Secon Technological Solutions Inc.**  
3rd Floor, Sri Bhagavati Complex, HMT Main Road  
Gokula 1st Stage, 2nd Phase, Bengaluru, Karnataka 560 054  
Telefax: 080 – 2357 5752 • E-mail: secontech2000@gmail.com

## Bagging System - Manual

Alligator Automations offers a wide range of Manual Bagging Systems. The features are: the process of manual bagging involves the placement of an empty bag on the clamp, manually, by the operator; the bag is then filled, released and dropped onto the sewing conveyor belt; it is straightened and fed to the sewing conveyor manually; the company provides complete turnkey solutions for bag filling requirements a variety of materials and bulk products can be packed by using open mouth filling systems; for gross weighing, the spout of the packer is suspended from an electronic load cell that accurately weighs the amount of product in the bag; its features include: accurate weighing; online bag metal detector; online bag check weigher; bag rejection; ink-jet printers and label applicators; centralized data logging system. The company provides turnkey automated solutions to industries like automobile, pharmaceutical, iron and steel, construction, consumer and many more.



Contact:

**Alligator Automations**  
Plot 5/6/11/12 , Gat 235, 2, Santosh Nagar  
Waki, Pune, Maharashtra 410 501  
Mob: 99701 54252, 90288 93000  
E-mail: sales@alligators.in

## Beam Welding Cutting Machine

Mansoori Weldarc India Pvt Ltd offers Structural Beam Welding Cutting Machine. The features are: the offered machine is manufactured using high grade components and contemporary technology by skilled experts; it is assured to the clients that the range is quality tested on pre-defined parameters, in order to meet industry standards. Apart from this, the clients can avail this machine, as per their needs, at a highly competitive price; it consists of transverse and longitudinal rack and pinion drives for accurate and reliable performance; the H-beam production line machine is easy to use as it has a user-friendly controller; this H-beam welding machine is value for money; a quality machine at a reasonable price; and it is available at the most pocket-friendly rate. The company, established in 2006, is counted among the most promising manufacturers, exporters, and traders of high performing welding machines.



Contact:

**Mansoori Weldarc India Pvt Ltd**  
23/7, Mathura Road, Near Castrol India  
Ballabgarh, Faridabad, Haryana 121 004  
Mob: 93131 03366, 98111 00410  
E-mail: Afzal@weldarcindia.com, director@weldarcindia.com

## Stainless Steel Pipes

Katariya Steel Distributors offers Stainless Steel Pipes. The features are: these pipes are manufactured with heavy machinery and skilled labor; they offer a flowless product range that fulfills the expectations of clients; an expert team of experienced professionals checks every product for quality before delivery; some of its advantages include that of a fine finish, excellent output, smooth conduction, low maintenance, cost effectiveness, high durability, sturdy construction, and ease of use. The company, founded in 1973, manufactures, exports, imports, and distributes a wide range of pipes, fittings, flanges, sheets, plates, fasteners, and other steel products for a variety of industries.



Contact:

**Katariya Steel Distributors**  
22/28, 3rd Panjrapole Lane Shop No. 2  
Cawasji Patel Tank Road, Mumbai 400 004  
☎ 022 – 2242 3168, 6636 3168 • Fax: 022 – 2242 1917  
Mob: 98334 05433, 98234 57777  
E-mail: katariyasteel@yahoo.com, sales@katariyasteel.com

## Parameter Measurement (3-Phase) - Model Nvis 7070

Nvis Technologies provides a diverse selection of the 3-Phase Parameter Measurement Model Nvis 7070. The features are: it measures voltage, current, frequency, active



power, reactive power, apparent power, and power factor; it is a very good product to measure 3-phase electrical parameters simultaneously without using individual meters; it is suitable to measure active, reactive, and apparent energy in both the 3-phase configurations such as WYE or DELTA; it works with both 3-phase 3-wire and 3-phase 4-wire systems; it has the best of the specifications and features in this particular segment, such as a microcontroller-based design for accurate measurement; a 240 x 128 graphical LCD display to view all the parameters simultaneously; it can be used with single-phase and three phase supply. The company is a leading technological solution provider in the education and environmental sectors.

Contact:

**Nvis Technologies Pvt Ltd**  
141-A, Electronic Complex, Pardesipura  
Indore, Madhya Pradesh 452 010  
☎ 0731 – 4211 500 • E-mail: info@nvisotech.com

## Concrete Cutter Machine

Jamshedji Constro Equip Pvt Ltd offers Concrete Cutter Machine. The features are: the entire range is fabricated using high-grade raw material and fitted with precision engineered components; the company offers an extensive range of concrete cutters, manufactured in line with the latest technological advancements; the range is tested on well-defined parameters to ensure that the final range offered is defect-free; to ensure high performance, these cutters are equipped with an energy-efficient engine and power motors; they are also provided with a water tank of 50 litres for high functionality. The company is engaged in manufacturing and exporting a wide range of construction machinery.



Contact:

**Jamshedji Constro Equip Pvt Ltd**  
A - 46 H Block, MIDC Industrial Area  
Pimpri, Pune, Maharashtra 411 018  
Mob: 91722 22137, 98501 53305 • E-mail: info@jamshedji.com

## Grid Tie Solar Inverter

Power-One Micro Systems offers Grid Tie Solar Inverter. The features are: this type of inverter provides net metering capabilities and helps in converting DC into AC, making customers self-sufficient in power generation and also helping them to produce enough power to give back to the local electrical grid; their grid tied solar inverters make power cuts



a dream for you without depending on diesel generators or battery powered inverter systems; the grid tied solar inverter can be customised to generate and provide solutions based on your needs; the features include: transformer-less design and compact design; IP65 Industrial production class; MPPT Efficiency > 99%; maximum efficiency 98%; mimic LCD display; optional remote monitoring through GPRS/Wifi Kit; wide voltage range for Synchronisation; wide frequency range for synchronization. The company is a leading manufacturer of power conversion technology in India. They have made a significant mark in the Indian market by pioneering in the fields of solar on-grid inverters, solar hybrid inverters, solar off-grid inverters, and solar power plants.

Contact:

**Powerone Micro Systems Pvt Ltd**  
5th Cross KSSIDC Building, GF3, Peenya 1st stage  
Peenya, Bengaluru, Karnataka 560 058  
☎ 080 – 2839 7832 • Mob: 90350 10265  
E-mail: rajeshmr@poweroneups.com

## GI Pipes

Industrial Piping Products offers GI Pipes. The features are: these pipes are designed and developed from high-grade materials; used in sanitary fittings in commercial and residential places, tested before dispatch to supply an error- and defect-free range, and available at reasonable prices with timely delivery. Some of the advantages are such long service life; lightweight; and sturdy design. The company, founded in 2007, is engaged as a manufacturer, trader, wholesaler, and retailer of a broad range of engineering products. The range includes pipe fittings, U-clamps, metal pipes, metal flanges, metal fasteners, tube fittings, butterfly valves, gate valves, ball valves, and many more.



Contact:

**Industrial Piping Products**  
3242, First Floor, Baba Baij Nath Market, Pipal Mahadev Gali  
Huaz Qazi, Chawri Bazar, New Delhi 110 006  
☎ 011 – 2326 7475 • Mob: 98113 77008, 93502 90172  
E-mail: industrialpiping2007@gmail.com

## Pneumatic Electric Cylinder

Metal Work Pneumatic India offers Pneumatic Electric Cylinders. The features are: the motor can be selected from an optimised range, which encompasses both stepping and brushless motors; there is a version for in-line assembly, where the drive shaft is jointed directly onto the screw; there is also a geared motor version, where transmission is provided by pulleys and a cog belt with a transmission suitable for motor drives; special adaptor flanges and joints can be provided if the customer wishes to use a particular make of motor; its features include optimum performance; extended working life; precise designing;. The company, which is an ISO 9001:2008 and ISO 14001:2004 certified organization, is engaged in the manufacture, supply, import, and export of pneumatic products. The range offered is widely acknowledged in the market for features like low maintenance, longer service life, a fine finish, light weight, and dimensional accuracy.



Contact:

**Metal Work Pneumatic India Pvt Ltd**  
No-18-20, 1st Cross, Industrial Area  
Adj Limb Compound  
Bannerghatta Main Road, Bilekahalli  
Bengaluru, Karnataka 560 076  
☎ 080 – 2648 0076, 2648 0012  
Mob: 98450 25416, 82176 03885  
E-mail: sales@metalwork.in

## Quick Release Couplers – Pneumatic

Vijay Air Control offers Quick Release Couplers – Pneumatic. The features are: it is uni-directional shut-off coupler with an automatic shut-off valve built in the socket; an excellent general purpose coupler for connecting factory air supply to pneumatic tool hose; important structural parts of steel models are hardened for added strength. Extremely wear resistance and durable; it is available in various body materials, sizes and connection types to suit a wide range of applications. The company is a one large workplace where work is done and then put on the market in the form of products and services. This work must be benefit if it is to hold its own in the face of competition.



Contact:

**Vijay Air Control**  
44/A, 59th 'A' Cross, 4th 'N' Block  
Rajaji Nagar, Bangalore-560010  
☎ 080 – 2314 8871, 2314 1136 • Mob: 89511 01436  
E-mail: saivacblr@vacpneumatic.co.in

## Waste Oil Heater

Elite Material Handling Co offers Waste Oil Heater - EL 75H. The features are: this energy logic waste oil heaters are the simplest to own and operate. That's because the heaters run on fuels from 5 to 90 weight (even synthetics) to maximise the efficiency and heat output of the waste oil you burn; the patented metering pump provides consistent, reliable fuel delivery, regardless of fuel type, without manual adjustments; and the stainless steel heat exchanger is able to withstand the higher temperatures produced by this burner. Stainless steel is also a superior heat conductor, which means you get warmer faster; its features include: heating up to 1,750 square feet, approximately one to four service bays; BTU input of 75,000 BTU (21.98 kW) per hour; fuel flow rate: 0.54 gallons/hour (2.0 liters/hour); heat rise over input air: 100-120°F (55.6 - 66.7°C); airflow: 500 cfm; exhaust flue diameter: 6"; dimensions: 75"H x 21"W x 26"L; weight: 210 lbs. The company provides logistics solutions in material handling related to transportation, storage, loading and unloading, and packaging.



Contact:

**Elite Material Handling Co**  
16, 3rd Cross Road, HAL 2nd Stage  
Doopanahalli, Indiranagar  
Bengaluru, Karnataka 560 008  
☎ 080 – 2521 6561, 6599 1403  
Mob: 93430 93181 • E-mail: eliteindia@yahoo.com

## Arc Welding Machine

Arc Welding Company offers Automatic Submerged Arc Welding Machine. The features are: the tractor mounted arc welding machine is designed to run on a track and can be mounted on the job placed adjacent to it to carry out welding; this feature allows the user to move the air welding machine from one place to another, the boom mounted arc welding machine is designed to mount on a column and boom assembly, side beam carriage, stationary fixtures and any other welding head manipulating device. The company established in 2002, is an authorized dealer of ESAB. Arc has established themselves as a well-known trader of welding machinery, equipment, spare parts and accessories allied products conforming to international standards.

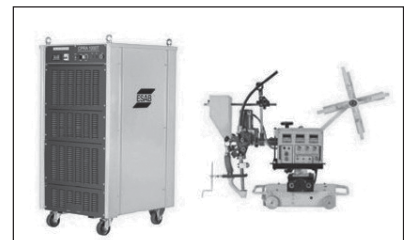

Contact:

**Arc Welding Company**  
Shop no. 7, CSC-1, DDA Market, GH 14  
Paschim Vihar, New Delhi 110 087  
Mob: 99992 00148 • E-mail: arcweldingcom@gmail.com

## Adhesive Sealants

Hitlock Adhesives India offers Adhesive Sealants. The features are: these sealants manufactured in a comprehensive range, formulated from natural and synthetic ingredients; these adhesives are chemical compounds in liquid or paste forms that adhere or bond two or more items together; available in various bonding strength, our range of extremely strong adhesive increasingly used in various industrial applications; and stringently checked and tested on several quality parameters, these products are flawless and deliver long bonding life even in adverse atmospheric conditions. The company is a manufacturer and importer/exporter of a wide range of industrial adhesives. Known for their high bond strength, cost-effectiveness and ease of applications, these multipurpose products are used for joining and fastening purposes in diverse industries.



Contact:

**Hitlock Adhesives India**  
104, Chandu Studio Compound  
Behind 2, Star Hotel, Kalina, Mumbai 400 098  
☎ 022 – 2666 0890/4195  
E-mail: info@hitlock.in

## Gravure Printing Machine

Mohindra Engineering Company offers Gravure Printing Machine. The features are: they are extremely valued for their sturdy construction, user friendly interface, durability, and low maintenance; they can be availed of with super simplex unwind and re-wind facilities; printing material - film, paper, aluminum foil, pet, BOPP, PVC film, polyester, bolyster, poly, metallised film, etc.; available number of colors - 1 - 8 colors; web width - 20" to 80"; the web roller is made of aluminum rollers or steel rollers; its features include unwind shaft - air shaft, tapper cone with solid shaft or shaft ness; tension controller - manually and auto registration control system (AC motor); in feed unit - synchronised control (AC motor). The company, which started in 1990, is a manufacturer and exporter of paper bag making machines, flexo printing machines, rotogravure printing machines.



Contact:

**Mohindra Engineering Company**  
RZ- 73, Nursing Garden, Near Khyala Village  
New Delhi 110 018  
Mob: 92126 58395, 99997 78804  
E-mail: mohindrimechanicalworks@gmail.com

## Sorting Automation Systems

Renovus Vision Automation Pvt Ltd offers Sorting Automation Systems. The features are: they offer an extensive range of high speed sorting automation systems that are configured with advanced technologies and modern tools; the products are in standard technical specifications and can be automated as per the preferences of clients; the design is based on a sorting automation system for component sorting based-color, size, shape, legend bar code, 3D matrix, QR code, and integrated packing after sorting. The company, specialises in designing, manufacturing, supplying, and trading a wide assortment of machine vision turnkey solutions, special purpose machines, inspection systems, automation systems, robot-based automation, high speed pick and place solutions, industrial cameras and lighting, and others.

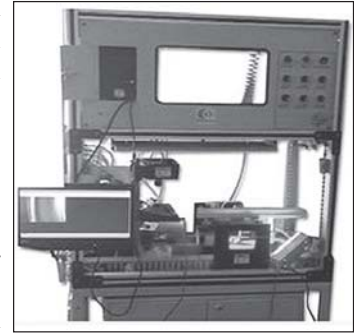

Contact:

**Renovus Vision Automation Pvt Ltd**  
No.13 , Singasandra, Aishwarya Crystal Layout  
Begur, Bengaluru, Karnataka 560 068  
☎ 080 – 6531 7777 • Mob: 90356 47777  
E-mail: jhon.khalkho@renovus.in

## Tube Bundle Heat Exchanger

United Cooling Systems provide a wide range of Tube Bundle Heat Exchanger. Their features are: an intermediate tube bottom, having insert tubes arranged concentrically in the tubes, is located in the inlet chamber; these insert tubes projecting out on both sides from the tubes and form annular spaces therewith; the heat exchanger has an inlet tube bottom and an outlet tube bottom, in which are fastened the ends of tubes which connect the bottoms and through which the medium of high inlet temperature flows; a tube bundle heat exchanger for cooling a medium having a high inlet temperature. The company is one of the world's largest total cooling tower and heat exchanger manufacturer, exporter and supplier apart. Product range includes cooling tower, heat exchanger, industrial cooler and many more.



Contact:

**United Cooling Systems (P) Limited**  
P.B. No. 4412, C-5, Private Industrial Estate, SIDCO Post  
Kurichi, Coimbatore, Tamil Nadu 641 021  
☎ 0422 – 2673 175 • Telefax: 0422 – 2676 082  
Mob: 94433 04342 • E-mail: info@unitedcoolingtower.com

## Ultrasonic Brass Inserts

Kalyani Sales Corporation is offering a range of Ultrasonic Brass Inserts. The features are: these ultrasonic brass inserts for plastic components are available in sizes ranging from M2 to M10 for all types of plastics, especially thermoplastics; brass inserts have two bands of opposite herringbone knurl and a pilot end for easy insertion; they are installed by ultrasonic vibration or heat transfer; in comparison to the conventional inserts, during moulding process, they remain firm and strong and are post moulded inserts with advantages like clean, reusable permanent threads; special brass inserts can also be availed on request. Primarily used in the avenues like automobile, electronics, home appliance industries, toys, hospital, laboratory and medical equipments, etc. The company engaged as a supplier of every kind of industrial fastener and primarily for thin sheet metal fabrication, with a highly productive manufacturing unit and efficient work force.



Contact:

**Kalyani Sales Corporation**  
Karveer Nivasini Housing Society, Building No. 58  
Flat No 3, 4 & 6, First & Second Floor, Near Ambai Tank  
Kolhapur, Maharashtra 416 010  
☎ 0231 – 263 0143 • Mob: 99605 50053  
E-mail: kalyanisalescorp@bsnl.in

## Extruded Rubber Cord

V H Polymers offers Extruded Rubber Cord. The features are: high temperature resistance (-50°C to +300°C); excellent resistance to oils, fuels, lubricants, and most mineral acids; corrosive fluids compared to other polymers; atmospheric oxidation, sun, and weather; fungus and mold; extremely low permeability to a broad range of substances; this rubber cord resists many aliphatic and aromatic hydrocarbons; excellent compression set values at high temperatures; resists degradation by over 300 fluids; good electrical properties at low voltage, low frequency; good mechanical properties at high temperatures; good mechanical strength over repeated flexing. The company started in 1981, is engaged in manufacturing and exporting a wide range of molded rubber components.



Contact:

**V H Polymers**  
Plot No: 279, Flat No: 9, Jawahar Nagar  
Goregaon West, Mumbai 400 062  
☎ 022 – 2344 7285 • Mob: 98212 44999  
E-mail: response@vhpolymers.com

## Pneumatic Denseveyor

Macawber Engineering Systems India offers Pneumatic Denseveyor. The features are: with most applications, level probes and outlet valves are not required to be mounted within the pressure vessel since the vessel closing device; the special relationship between vessel capacity and pipeline insures the movement of material without dependence on material fluidization, pipeline boosters or high velocity smooth, low-velocity dense-phase pneumatic conveying of powders, granules and irregularly shaped materials without degradation or segregation; hot, wet, fine or coarse, blended or batched denseveyor handles them all. Phase density, two important features of the denseveyor design, combine to provide a non-fluidizing conveying technique, which in turn reduces air requirements. The company is a manufacturer and supplier of pneumatic conveying systems, dense phase pneumatic conveying systems, and material handling systems.



Contact:

**Macawber Engineering Systems India Private Limited**  
Hindustan Kohinoor Industrial Complex, 130-131  
Lal Bahadur Shastri Road, Vikhroli West, Mumbai 400 083  
☎ 022 – 2579 4624 • Mob: 98673 55413  
E-mail: sales@macawberindia.com

## Automatic Biscuit Making Plant

Ultra Worldwide offers Automatic Biscuit Making Plant. Its features are: this machine makes and cuts biscuits in the desired shape from the dough sheet supplied by the sheeters/gauge rollers; the dough sheet is made of fermented dough or soft sweet dough; one roll is used for printing and the other for cutting, resulting in continuous top quality production; pneumatic side tracking control with individual speed controls (VFD); independent speed control for cutting web and cutting rolls for smooth and accurate cut. The company, established in 1995, is one of the leading manufacturers and exporters of food processing and other allied machines.



Contact:

**Ultra Worldwide Private Limited**  
201 Joshi Chambers, Ahmedabad Street, Iron Market  
Near Masjid Railway Station, Chinch Bandar, Mumbai 400 009  
☎ 022 – 2348 1424 • Mob: 98210 64899  
E-mail: ultra\_international@vsnl.com



## Wrapping Machine

Sharp Engineering offers Luggage Wrapping Machine. The features are: it is suitable for fast transporting and storing; adopting programmable logic control reliable in performance, convenient in operation; it can protect the package against dust and damp or damage; photocell detector automatically senses luggage height; the machine can wrap a big luggage as 850 mm in height; with pre-stretch carriage, pre-stretch rate up to 300%, film savings; holder speed adjustable; film tension adjustable; easy tracking for wrap counter device uniquely designed for packaging luggage, cargoes and goods in airports, docks and stations. The company, founded in 1996, is an exporter, manufacturer, wholesaler, trader, and retailer of packaging machines. The product lines are strapping machines, carton sealing machines, and hand pallet trucks. These are used, extensively in diverse industries such as pharmaceuticals, paint, rubber, paper, and many more.

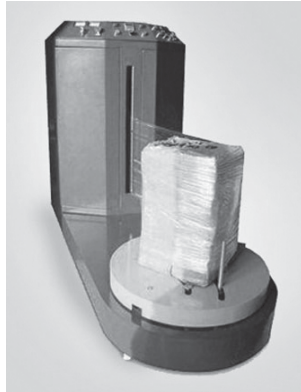

Contact:

**Sharp Engineering**  
2, Ramprasad Yadav Compound, Lane Number 1  
Near Jain Dairy, Koldongri, Andheri East, Mumbai 400 069  
☎ 022 – 2683 5583 • Mob: 98209 39960  
E-mail: response@sharpstrapping.com

## Polifan Flap Discs Z SG

PFERD offers a wide range of Polifan Flap Discs Z SG. The features are: the flap disc polifan power stands out due to its aggressive stock removal rate and excellent tool life while achieving the highest level of efficiency; it is the best conventional flap disc for steel; its benefits are: rimming the tool enables the abrasive to be used optimally; fast work progress and maximum economic efficiency thanks to the aggressive stock removal rate; maximum aggressiveness over the entire tool life; fewer tool changes due to the excellent tool life. The company is engaged in the development, production, support, and distribution of tool solutions for jobs involving surface and material cutting.



Contact:

**PFERD**  
326, B-Block, AECS Layout, Brookefield  
Bengaluru, Karnataka 560 037  
☎ 080 – 4218 7117 • Mob: 98806 65415, 97414 81117  
E-mail: sales@swit.in

## Pneumatic Welding Guns

Shreeji Weld Industries offers Pneumatic Welding Guns. The features are: the offered pneumatic gun is manufactured using the best grade raw material and latest tech-

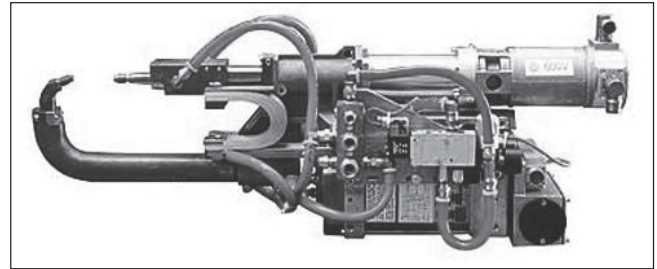

nology in compliance with the international quality standards; these are appreciated among clients due to their high performance, robust construction and compact structure; automatic change in welding parameters with forces as per sheet combination detected; no operator dependency for welding parameter change; free programmable mid position for high lift opening; “Soft touch” of electrodes at time of gun close; and usage of maximum parts from standard IT gun for reduction in spare variety. All electrical specifications remain same as standard pneumatic guns. The company established in the year 2000, is amidst the innovative business names readily instrumental in the area of manufacturing and exporting a comprehensive variety of products.

Contact:

**Shreeji Weld Industries**  
Gala No.42/43, Lotlikar Compound  
Tondre Village, Behind Hindalco Company  
Near Water Tank, Taloja  
Navi Mumbai, Maharashtra 410 208  
Mob: 93232 75103 • E-mail: shreejiweld@gmail.com,  
shreejiweld.com

## Blasting Machine

Guru Nanak Manufacturing Company offers Shot Blasting Machine. These machines are used in the finishing of industrial components and products; they are manufactured by experts using the finest grade materials in accordance with industry standards; they are machine checked by experts for quality across several parameters to ensure a defect-free product; they are available at very low prices; and the specifications are as follows: maximum load on table: 1 ton; maximum job height: 1000 mm; and door options: The company, founded in 1998, is engaged in the manufacturing and supply of a wide range of blasting machines. This includes: tumblast blasting machines, tumblast shot blasting machines, tabletop model shot blasting machines, single hanger shot blasting machines, etc.

Contact:

**Guru Nanak Manufacturing Company**  
Kamal Park, 42/2, Near Aman Nagar  
Aman Nagar, Jalandhar, Punjab 144 004  
☎ 0181 – 509 1321 • Mob: 98154 96000, 95175 11368  
E-mail: metalfinishing@yahoo.co.in

## AC Fail Annunciator

JVS Electronics offers a wide range of AC Fail Annunciator- JAV 016. The features are: JAV 016 -AC fail annunciation module. When the AC supply in the panel fails, an announcement to this effect is required. This unit works with DC auxiliary supply for AC fail indication respectively. The unit will get energised through the N/C contact of the in-built AC supply monitoring relay; a set of separate hooter contacts are provided for connecting the hooter in the unit for getting audible annunciation. The AC fail unit will have a DC hooter; its features include: display through super bright SMD LEDs; built-in test and accept push buttons; a built - in AC fail relay; and a compact, moulded case. The company is an exporter, manufacturer, and supplier of audio indicating instruments, visual indicating instruments, electrical indicating instruments, etc.



Contact:

**JVS Electronics Pvt Ltd**  
#121, Manchanayakanahalli, Bangalore Mysore Highway  
Bidadi, Ramanagara, Bangalore, Karnataka 562 109  
Mob: 94482 88863 • E-mail: Bangalore@jvselectronics.in

## Industrial Infrastructure Lighting

Bajaj Electricals Ltd offers Industrial Infrastructure Lighting. The features are: infrastructure lighting requires a holistic approach with specific solutions for different func-



tions; the company is committed to developing such large-scale projects across India; this BU is present in the segments of manufacturing plants, railways, airports, BRTS, ports, corporations, and logistics parks; it has also developed lighting as a base to give complete solutions for exceptional energy and maintenance savings. The company, a globally renowned and trusted company, is a part of the Bajaj Group. Their operations include consumer products (appliances, fans, lighting), luminescence exports, and EPC (Power Transmission and Distribution).

Contact:

**Bajaj Electricals Ltd**  
45/47, Veer Nariman Road, Kala Ghoda, Fort, Mumbai 400 023  
☎ 022 - 2204 3841, 2204 5046

## Pharmaceutical Dust Collector

Imperial Pharmachines Pvt Ltd offers Pharmaceutical Dust Collector. The features are: this dust collectors are become a necessity in most pharmaceutical companies; these not only improve the tablet quality but also increase production by ensuring trouble free production and allowing running of tablet presses at higher speeds; normally a lot of dust is generated during the compression process. This dust if not controlled would settle in the upper punches, turret and other parts in the compression zone; excess dust in the compression zone can lead to black particles, upper punch jamming and various other problems; and it is therefore advisable to have a dust collector unit attached to the tablet press to suck out the dust generated. The company a four decade old company, engaged in manufacturing of pharmaceutical machines and tools.



Contact:

**Imperial Pharmachines Pvt Ltd**  
136, Shivkrupa Industrial Estate  
LBS Marg, Vikhroli West, Mumbai 400 083  
☎ 022 - 2578 1989, 2577 0554  
Fax: 022 - 2578 0000 • E-mail: sales1@pharmachine.in

## Steam Boilers, Vertical

Fuelpac Boilers & Engineering Company India offers a wide range of Steam Boilers, vertical. The features are: designed and developed in compliance with industry defined principles, making use of pristine quality basic materials purchased from certified sellers in the industry; rigorously tested on a number of parameters to guarantee their flawlessness and high quality; these product features include excellent performance, a longer service life; and the least maintenance. The company, established in 1984, offers products such as steam boilers, thermic fluid heaters, electrode electrical boilers, hot water generators, hot air generators, chemical process equipment, heat exchangers, water storage tanks, and heating system accessories.



Contact:

**Fuelpac Boilers & Engineering Company India Pvt Ltd**  
H-1/94, Gujarati Society, Opposite Dahanukar College  
Near Adarsh Petrol Pump, Mumbai 400 057  
☎ 022 - 2611 2782, 2613 3361 • Fax: 022 - 2611 0457  
Mob: 91678 55580, 98208 64432  
E-mail: fuelpac@fuelpacboilers.com, fuelpacjoban@gmail.com

## Mig Mag Welding Machine

Warpp Engineers offers Mig Mag Welding Machine. The features are: these machines are available in 250, 350, 500 and 630 amps range; it has advanced soft switching inverter technology, low spatter; continuous adjustment of welding voltage and current; slow start facilitates easy arc striking; it is specialities include reduced melting ball at the end of welding; high operating frequency hence small size and weight; high power factor and efficiency; it has a preset digital display of welding voltage and current; default current/voltage match makes it easy for operation. The company was established in 1994 by setting up its design, production, and quality management facilities in Mumbai. Over two decades of experience in welding and plasma products have greatly helped Warpp establish itself in the Indian welding equipment market.



Contact:

**Warpp Engineers Pvt Ltd**  
Survey No.36, House No.15/3, Little Lacy House  
Unique Industrial Complex, Dhumal Nagar, Golani Naka  
Vasai East, Waliv, Palghar, Maharashtra 401 208  
Mob: 93246 82069, 98205 61818  
E-mail: warp@vsnl.com, info@warpp.co.in

## Seam Welding Machine

Vijay Electricals offers Seam Welding Machine. The features are: these machines are manufactured without compromising on quality and use high quality spare parts and components; their team of logistics personnel makes sure that the consignments are timely delivered at customers' destinations; and this machine is applicable in engineering industries for body clamping and feeding. This machine is widely appreciated for its construction, durability, and corrosion resistance; the capacity varies from 202 to 700 diameter cans (extra arm is required for 202 diameter cans), and the welding speed ranges from 10 to 15 meter /minute. The output quantity is 20 to 30 sheets per minute, the electricity - 15 KVA 50 hz and the net weight is 600 kg. The company, established in 1985, is one of the leading manufacturers and suppliers of a wide range of high-quality welding machines.

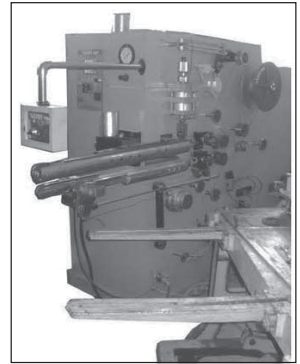

Contact:

**Vijay Electricals**  
Plot No. 9, Ballabgarh Sohna Road  
Nangla Gujran 60 Feet Road, Faridabad, Haryana 121 004  
Mob: 98911 49638 • E-mail: ajay\_giri1981@yahoo.co.in

## Attention Readers...

*If you are a manufacturer or dealer of any industrial product,  
we invite you to  
send your Product write-ups for Free publication,  
in about 200 words describing the product, such as  
its technical specifications, special features, applications, etc,  
along with a clear photograph of the product to:*

**ipseditor@gmail.com or**

*The Editor*

## Industrial Products Source

**Product News Publication**

104, Sudama Yash, Kelkar Cross Road  
Nr: Ramkrishna Hotel, Ram Nagar, Dombivili (E), Thane 421 201

## Pneumatic Positioners

Susin I-Tork India offers Pneumatic Positioners, SSL & SSR series. The features are: SSL & SSR series have a high performance pilot valve coupled with piezoelectric technol-



ogy and achieve the smartest control with various setting functions; its features include auto-calibration for optimum conditions; precise control performance and high dynamic response; easy operation with four-key pads and full text graphical LCD; single and double acting actuators; low air consumption due to piezo electric microvalve; pressure regulator built-in to eliminate variations in supply air pressure; problem-free characteristics on very small actuator; economical energy saving; extremely vibration resistant design; high resistance against shock and vibration; mounting on linear actuators according to IEC 534; mounting on rotary actuators according to VDI / VDE 3845. The company, an ISO 9001:2000 certified company, manufactures a full range of valve and damper automation products.

Contact:

**Susin I-Tork India (P) Ltd**  
4/134 - B, Thadagam Road, KNG Pudur Cross  
Coimbatore, Tamil Nadu 641 108  
☎ 0422 – 2406 026, 6505 426  
E-mail: info@susinitork.in

## Microprocessor Based Engineering Unit Model EU-08 RTP

Nippon India offers Microprocessor Based Engineering Unit Model EU-08 RTP. It has Hi and Lo Alarm set point with Relay O/P and Process Value (PV) Re-transmission 4~20 mA DC with 24 V DC Transmitter Supply, all input and range programmable from front panel switches. Input Sensor: T/C – Type: J/K/R/S/T/E; RTD – Type: PT 100/CU-53; Analogue: 0-10 V DC/ 4~20 mA DC (Scalable – 1999 to 9999 with selectable DP); Display: 0.8" height, 4-digit; Mains: 180 ~ 264 V AC, 50 Hz; Dimensions: 48 mm (H) x 96 mm (W) x 78 mm (D).

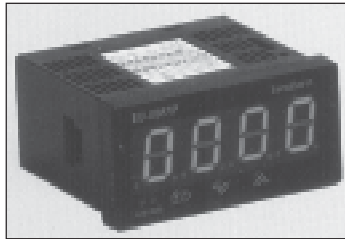

Contact:

**Nippon India**  
237/8 New Sonal Link Indl Estate, Building No: 2  
Link Road, Malad (West), Mumbai 400 064  
☎ 022 – 4062 0000 • Fax: 022 – 4062 0099  
E-mail: sales@nipponindia.com

## Light Duty Cross Flow Fan – Centrifugal Blowers

Delco Fans Pvt Ltd offers a wide range of Light Duty Cross Flow Fans—Centrifugal Blowers, a new product line particularly well suited to small systems. The features are:

where concentrated air-flow, space, and noise levels are serious considerations; airflow available from 40 to 2400 CFM at zero static pressure; available from 18 watts to



1 HP, in single and three phase; driven by a quality performed light weight shaded pole / TEFC motor having 2800 RPM; products manufactured using the most sophisticated technology; aluminum, MS, and SS impellers available; low power consumption and long-life expectancy light weight with high mechanical stability; equipped with precision ball bearings having plastic or metallic outer casings; application areas: business machines; wave soldering machines; gas chromatographs; popcorn machines; office equipment's pumps; appliances. The company was founded in 1975, and their manufacturing range consists of FHP electric motors, geared electric motors, centrifugal blowers, and industrial fans; presently, they have more than 900 customers in India. Their motors are used in the following equipment: panel coolers; blood bank equipment; laboratory equipment; and many more.

Contact:

**Delco Fans Pvt Ltd**  
Plot No. A/388, Road Number 28  
CP Talav, Wagle Industrial Estate  
Thane West, Maharashtra 400 604  
Mob: 97692 01564 • E-mail: delcofans@gmail.com

## Cyanoacrylates Adhesive

Priya Components offers Cyanoacrylates Adhesive. The features are: cyanoacrylates adhesive are one-part acrylate adhesives. They cure instantly on contact with a mated surface through a reaction with surface moisture; these are commonly called "super glues. Cyanoacrylates adhesive have high strength and excellent adhesion to a wide variety of substrates; the cyanoacrylate systems are offered in a wide range of viscosities, curing times, gap filling, shear strengths, and temperature ranges. The company, founded in 2008, is engaged in the trading and supply of a highly reliable range of Teflon tapes, hose pipe clamps, adhesives and sealants, aluminium bottles, glass bottles, plastic bottles, strapping rolls, McCleod gauges, etc.

Contact:

**Priya Components**  
A-4, Old Padra Road, Behind Rajvee Towers  
Anupam Nagar, Sahkar Nagar  
Tandalja, Vadodara, Gujarat 390 020  
Mob: 99250 23362  
E-mail: priyacomponents@yahoo.co.in

## Superior Quality Cutter-Crushers

Rajat Equipments offers Superior Quality Cutter-Crushers. The features are: they are available in various models and can be customised as per specifications; they have sturdy construction with less maintenance and efficient performance; high-wear-resistant cutting blades placed separately from the crushing area, which are easy to change; and high-wear-resistant crushing teeth. Pulverizer pads, steel demolition jaws, and wood cutting blades are also available; the sealed slew ring doesn't require maintenance apart from standard greasing; it is available in power rotation and free rotation types, including mechanical brake and water jet options; it is light-weight and has a short cycle. The company manufactures and supplies a wide range of vessels and construction equipment. They ensure that the manufacturing adheres to industry standards, using the finest raw materials and advanced technology to ensure performance, capacity, service life, strength, and precision.



Contact:

**Rajat Equipments Pvt Ltd**  
Plot No. 33, Bhanpuri Road, Near Police Station  
Industrial Area, Bhanpuri, Raipur, Chhattisgarh 492 001  
Mob: 98264 21900 • E-mail: info@rajat-group.com

## Fiber Laser Marking Machine

Asian Machine Tool Corporation offers Fiber Laser Marking Machine. The features are: to fabricate this range precisely, executives make use of finest class basic material together with modern tools to retain its defect free nature; this massive industrial know-how and market familiarity are actively committed to delivering a splendid array of laser marking machines; the array is well examined before getting shipped at the premises of their clients; the product is rugged with high functionality and durability. The company founded in 2012, offers a wide collection of marketing machines to their customers. They use top notch quality material and examine products properly before delivery.



Contact:

**Asian Machine Tool Corporation Pvt Ltd**  
Gat No 1239b, Office No3, F Wing  
Mulshi Vaibhav, Next To Pirangut Police Station  
Village Pirangut, Pune, Maharashtra 412 108  
Mob: 88054 95151 • E-mail: md@amtepl.com

## Autonomous Measuring Cells with Integrated Handling Robot

Blum-Novotest Measuring & Testing Technology offers a wide range of Autonomous Measuring Cells with Integrated Handling Robot – BMK5. The features are: the measuring and automation concept BMK 5 is a variable measuring cell that can be expanded with modules; it can perform additional tasks such as sorting, labelling and packaging of components if the corresponding modules are integrated; applicable as stand-alone system or as in-line module in a machine tool; integrated as an in-line system with correction control loop or as an autonomous post-process test system; and it has flexibly equipped working area and high efficiency by minimum setup costs. The company has made a name for itself in the list of top suppliers of bore gauge, radio receiver in India.



Contact:

**Blum-Novotest Measuring & Testing Technology Pvt Ltd**  
No. 06 (Old No. 107) 2nd Floor, 1st Main Road  
Widia Layout, Attiguppe, Bengaluru, Karnataka 560 040  
☎ 080 – 2318 5468 • Mob: 90750 04435  
E-mail: info@blumnovotestindia.in  
shyambv@blumnovotestindia.in

## Two Wheeler Battery – GmC-CS-2.5LC

Gem Batteries offers a wide range of Gem Two Wheeler Battery – GmC-CS-2.5LC. The features are: Gem ensures minimum topping up frequency during high temperature abusive operation; patented dry charge technology assures 20% higher performance even after longest storage life; unique polyethylene separator with glassmatt back-up provides longest life in the most arduous operating environment; double seal terminal/pole design ensures leak-proof operation; patented grid alloy composition for long life and minimum water loss; and optimum designed plates with maximum surface area ensure highest cranking power for instant ignition. The company is engaged in manufacturing automotive, inverter and tubular batteries under the brand name Gem. It is ISO 9001:2000 certified company that has pioneered, implemented and introduced some of the most mission-critical solutions in the battery, inverter and UPS industry.



Contact:

**Gem Batteries Private Limited**  
B-2/11, M.C.I.E., Badarpur, New Delhi 110 044  
☎ 011 – 4064 5555 • Fax: 011 – 4064 5556  
E-mail: info@gembatteries.com

## Tube Filling Sealing Machine

Veena Pharma Machinery provides Tube Filling Sealing Machine. The features are: this tube sealing machine uses a rotary type of cup rotation with the help of an indexer; in automatic tube sealing machines, tube holders are made from aluminium and coated tube holders have to be changed for different tube diameters; the output speed ranges from a maximum of 20 to 25 tubes / min. Output speeds vary according to different grammages or different tubes; and in an automatic tube sealing machine, filling accuracy is  $\pm 1\%$ . Tubes are melted here to improve the performance of the water-jacketed unit. The company, established in 1994, designs and delivers innovative and affordable packaging machines and is now a trusted name in the small-scale industry segment.



Contact:

**Veena Pharma Machinery**  
A-2/4, Padmini Industrial Complex, Kalher Pipe Line Road  
Near Gundvli Gaon, Purna Village  
Bhiwandi, Thane, Maharashtra 421 302  
Mob: 93239 58996, 90045 63628, 99677 07369  
E-mail: sales@veenapharma.com

## Portable Non Maintained Lights

Autolite Emergency Lighting System LLP provides Portable Non Maintained Lights. The features are: the offered product automatically switches-ON on mains power failure and provides illumination from the battery source for a specified duration; once it is totally charged, the battery gets automatically cut-off, to facilitate quick recharge on resumption of mains supply. The company has been manufacturing emergency lighting systems for any requirement and different applications, thus increasing the range of models. The emergency lights are provided with a perfect mounting arrangement so that they can be easily installed on a wall or ceiling with minimum effort.



Contact:

**Autolite Emergency Lighting System LLP**  
406, Sohan Commercial Plaza, Navghar Road  
Near Railway Station, Vasai (E), Palghar, Maharashtra 401 210  
☎ 0250 – 6598 444 • Mob: 98331 08571, 80876 66677  
E-mail: info@autolite-india.com

## Diamond Grinding Wheels

Wintech Diamonds Products offers Diamond Grinding Wheels. The features are: these diamond/CBN grinding wheels and rollers are used for milling hardened material's, polishing surfaces, polishing rough edges, removing unwanted burr's, creating radius edges, fillet corners and for many more applications; all types of diamond grinding wheels can be manufactured by Wintech, no matter the size or shape; the quality of our products is unparalleled and renowned; its features include: diamond/CBN grinding wheels are very easy to operate and easy to adapt with various applications; they provide greater grinding ability and suitable for many materials because of their unique bonding structure. The company is a result of technical know-how that brings about optimum tool performance, providing fast cutting without sacrificing their long lifespan.

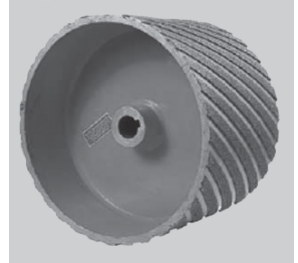

Contact:

**Wintech Diamonds Products**  
Old No. 132, New No. 45, Harivaradhan Street  
Santhosh Nagar, Kandanchavadi  
Chennai, Tamil Nadu 600 096  
Mob: 80562 24669, 98403 17793  
E-mail: wintechdiamondravi@gmail.com

## Cone Hydro Extractor

Guruson International offers a wide range of Cone Hydro Extractor. The features are: this machine with three-leg suspension to check vibration created by unbalanced rotating fabric/material; internal rotating perforated basket is dynamically balanced and made up of stainless steel (304); the body structure is made of graded cast iron and provided with heavy-duty steel springs; special construction with a formed basket and equipped with spindle to take up yarn cones, the special basket shape and movable spindle ensure excellent extraction of cones without distorting the shape; its features include: high speed machine; leaves less moisture; auto timed; automatic brake; easy to operate; and outer and inner drum stainless steel. The company established in 1985, is a prominent manufacturer and exporter of a wide range of industrial dyeing, washing, dry cleaning and finishing systems.



Contact:

**Guruson International**  
2512/10, 9 B/3, Industrial Area- A Extension, Transport Nagar  
Industrial Area- A, Ludhiana, Punjab 141 003  
☎ 0161 – 505 6246 • Fax: 0161 – 501 5297  
E-mail: guruson@rediffmail.com, info@guruson.com

## Computer-Controlled Pipecutter, 4-Axis

Mehta Sanghvi & Co offers a wide range of 4-axis Computer-Controlled Pipecutter, Model W-244, from Watts Specialties Inc, USA. Features are: this is a 24-inch, rugged computer-operated 4-axis machine that is simple to use and highly productive. It produces variable bevel angles, and fully beveled holes; its 4-axis control for controlled bevels and deep weld penetration; the W-244 is controlled by a heavy-duty industrial computer designed to run in extreme temperature, humidity and vibration; this easily programmable system is accurate, reliable, easy to maintain and easy to operate. With this machine one can cut any contoured pipe-end in minutes. By using the simple computer menu one can also set up saddle holes, slots, rectangles or other custom cuts. The company is a trader, manufacturer and supplier of industrial safety and welding equipment and accessories.



Contact:

**Mehta Sanghvi & Co**  
**Industrial Unit No: 21, Gr Floor, Gokul Industrial Estate**  
**Premises Co Operative Society, Plot No: 150**  
**Sir Mathuradas Vasanji Road, Marol**  
**Andheri East, Mumbai 400 059**  
**☎ 022 – 2859 2847 • Mob: 98201 27614**  
**E-mail: mehtasanghvi.k@gmail.com**

## Firefighting Panel

Koyka Electronics offers quality Firefighting Panel, which is manufactured by experts using high grade components and innovative technology; available in different designs and sizes as per the needs of clients, within a specific time frame; it works for both manual/auto mode; when pressure drops the booster pump kick-starts automatically to keep the main line for desired pressure; and easy connection installation; available in wall mounting /floor mounting; operating voltage - AC 220 V - 380 V; power - 200 W; working temperature - 20°C - 50°C. The company is a manufacturer, importer, exporter and supplier of a various types of sealing machines, packaging machines, filling machines, powder packing machines, food processing machines, snacks making machines, multihead weigher machines, etc.



Contact:

**Koyka Electronics Pvt Ltd**  
**1165 Sector-7D, Mathura Road, Faridabad, Haryana 121 006**  
**Mob: 98105 01205 • E-mail: harsh@koykagroup.co.in**

### Subscription Order Form

To,  
 The Circulation Manager  
**Product News Publication**  
 104, Sudama Yash, Nr. Ramkrishna Hotel  
 Kelkar Cross Road, Ram Nagar, Dombivli (E), Thane 421 201

Dear Sir,

I / We would like to subscribe **Industrial Products Source**.

Please commence my/our subscription with the \_\_\_\_\_ (Month & Year) Issue.

Name \_\_\_\_\_

Address \_\_\_\_\_

\_\_\_\_\_

\_\_\_\_\_ Pin code \_\_\_\_\_

Telephone \_\_\_\_\_ Mobile No. \_\_\_\_\_

Date: \_\_\_\_\_ Signature \_\_\_\_\_

## Industrial Products Source

Visit us at: [www.ips.co.in](http://www.ips.co.in) / [www.industrialproductssource.com](http://www.industrialproductssource.com)

1-Year (12 issues) ₹ 300/-

2-Year (24 issues) ₹ 550/-

3-Year (36 issues) ₹ 750/-

*Subscribers who wish to receive magazine through courier, will be charged extra*

I / We enclose the payment of Rs. \_\_\_\_\_

in favour of **PRODUCT NEWS PUBLICATION**,

by "A/c. Payee" Draft / Cheque No. \_\_\_\_\_

Dated \_\_\_\_\_ of Bank \_\_\_\_\_

Our Bank details for NEFT payment Transfer:

Name of the company: **PRODUCT NEWS PUBLICATION**

Name of our bankers: IDBI BANK, Dombivli (East Branch)  
 Thane Dt.

A/C NO: 118102 00000 6569

Nature of Account: Current

IFS Code: IBKL0000455

## Mosfet Base Welding Machine

Welding Aids offers DC TIG (inverter base) Mosfet Base Welding Machine. This welding machine is soft switch technology, high efficiency, low power consumption; automatic protection from over current, over heat, over/under voltage; TIG welding and MMA welding; it has up/down slope of welding current



arc pre & post flow of gas and with automatic HF control. In TIG welding stich welding option is also provided; it is suitable for welding of the stainless-steel parts, pressure vessels and pipeline, provide more efficiency; and it is Light in weight, portable, multi purpose TIG/MMA machine, reliable arc starts with HF, deep penetration, easy arc striking, stable current, high speed and dynamic response, noise free, and ensures spatter less welding. The company is engaged in trading, importing, and providing service for a wide range of welding and cutting equipment, such as welding cutting machines, portable cutting machines, etc.

Contact:

### Welding Aids

No. 4033, Ajmeri Gate, New Delhi 110 006

☎ 011 – 2321 4114 • Mob: 98110 62635, 98119 45400

E-mail: [weldingaids@gmail.com](mailto:weldingaids@gmail.com)

## Line Interactive UPS

Powerone Micro Systems offers Line interactive UPS. The features are: it is used for small business, web and departmental servers; providing complete protection to your computers and electronic equipment against surges, blackouts and power fluctuation; these UPS are your perfect choice; for equipment with larger power requirement, their line interactive UPS system are the most reliable by providing solid battery backup to maintain sufficient power to save work when the power fails; these Line interactive UPS are being used by various small Industries, household works and IT Sector around the globe; its features include: high Efficiency; wide input range suit for any condition; high reliability due to digital controllers; change over time less than 4 milli seconds; and sleek and Low foot print. The company is a leading manufacturer of power conversion technology in India.



Contact:

### Powerone Micro Systems Pvt Ltd

5th Cross KSSIDC Building, GF3, Peenya 1st stage

Peenya, Bengaluru, Karnataka 560 058

☎ 080 – 2839 7832 • Mob: 90350 10265

E-mail: [rajeshmr@poweroneups.com](mailto:rajeshmr@poweroneups.com)

## Fire Retardant Coating

Marco Trading Company offers Fire Retardant Coating. The features are: fire retardant coating is a safety product that prevents the rapid spread of fire, allowing time for extinguishing it before it spreads rapidly; the product is processed under the surveillance of adroit professionals using optimum quality chemical compounds and sophisticated technology; it is acknowledged for its quality and effectiveness. The product goes through stringent inspection by quality experts before delivery; it is available at economical prices, and its benefits include being accurate in composition, having a longer shelf life, and being highly effective. The company is engaged in the supply and trading of a range of fastener products and safety equipment. This comprises hammer anchors, fixing anchors, injection systems, safety shoes, steel fasteners, nut fasteners, plasma cutters, protective gloves, etc.



Contact:

### Marco Trading Company

1/2, Udhana - Sachin Hwy, New RBL GIDC Colony

Madhav Nagar, Pandesara, Udhana, Surat, Gujarat 394 221

Mob: 96388 86161 • E-mail: [info@marcouae.com](mailto:info@marcouae.com)

## Hydraulic Machine Oil Cooler

Mark Engineers offers Hydraulic Machine Oil Cooler. The features are: hydraulic oil coolers designed to deliver superior cooling effect as well as complete accuracy in terms of feed as well as speeds, thus providing for products within defined tolerance limits; effective heat transfer rates, in-built fan support makes these suitable for cooling in-accordance with dry bulb temperatures; use of precision designed machine parts also result in low wear and tear; it designed to deliver superior cooling effect and complete accuracy in feed as well as speeds, thus providing for products within defined tolerance limits; designed for achieving effective heat transfer rates; and hydrostatically tested so as to ensure optimal functional support. The company established in 1997, is engaged in manufacturing export/import and of a wide range of products for process industry.



Contact:

### Mark Engineers

312/2, Phase-II, H Road, G.I.D.C Estate

Vatva, Ahmedabad, Gujarat 382 445

☎ 079 – 4008 3134, 2583 6558

Mob: 98250 12504, 98250 30474

E-mail: [markheatcool@gmail.com](mailto:markheatcool@gmail.com), [info@markheatcool.net](mailto:info@markheatcool.net)



## Welding Rotators

Arcraft Plasma Equipments offers Welding Rotators. The features are: these self aligning welding rotators are manufactured in compliance with the industry set standards and are widely used for welding applications; it is available with them at affordable prices, these welding rotators are highly appreciated among the customers; the heavy duty structure made out of fabrication steel; it is extremely robust and vibration free; backlash free gear box ensures jerk free rotation; irrespective of diameter job remains central to the frame of the rotator; and optional anti-drift mechanism facility available; suitable for interfacing with NC or CNC controllers. The company founded in 1992 is an ISO 9001-2008 certified company are listed as the most renowned manufacturers, suppliers, exporters and service providers of a wide range of supreme quality welding, cutting machines and automation systems.



Contact:

**Arcraft Plasma Equipments (India) Pvt Ltd**  
124 ,Diamond Industrial Estate, Ketkipada, Dahisar (East)  
Near Dahisar Check Naka, Mumbai 400 068  
☎ 022 – 2896 5890, 2896 3247  
Mob: 98206 84001, 9819163287  
E-mail: [arcraftplasma@gmail.com](mailto:arcraftplasma@gmail.com)

## Magnetic Crack Detectors, Maxiflux Stationary Type

Eastwest Engineering & Electronics Pvt Ltd offers Maxiflux Stationary Type Crack Detectors, which are general purpose heavy-duty bench type crack detectors. They are most suitable to test Crankshafts, Connecting Rods, Bars, Billets and many other types of ferrous components. The Crack Detector typically consists of a stationary Head stock and crank operated tail stock. Common Standard Features: Sturdy steel frame work construction; Pneumatic clamping with soft contacts with copper braiding pads to avoid sparking; Stainless steel V shaped test tray; Stainless steel tank with pump, hose and spray gun for spraying magnetic ink; Collapsible canopy to create dark area for Fluorescent particle testing; Auto push button Demagnetization; Black light (UV light) with High Intensity lamp and UV filter.



Contact:

**Eastwest Engineering & Electronics Pvt Ltd**  
D-191, MIDC, Nerul, Navi Mumbai 400 706  
☎ 022 – 2768 6241 • Fax: 022 – 2768 6245  
E-mail: [info@eastwestndt.com](mailto:info@eastwestndt.com)

## High Tension Transformer

Muskaan Power Infrastructure offers a wide range of High Tension Transformer. Features are: high tension transformer with state of the art technology two-in-one system; servo controlled automatic voltage controller either on LT side or HT side; transformers with built-in rolling contact Type AVR; suitable for indoor/outdoor installation; copper wound HT two-in-one system; the standard off-circuit tapping of transformers can correct limited voltage variation; equipment is basically a combination of HT AVR with a standard distribution transformer; and fluctuating voltage from grid is controlled by the HT AVR; LT output within  $\pm 1$  per cent accuracy; higher efficiency makes the distribution transformer to utilize up to 100 per cent capacity. The company is engaged in manufacture, supply and export of a wide range of electrical and power equipment.

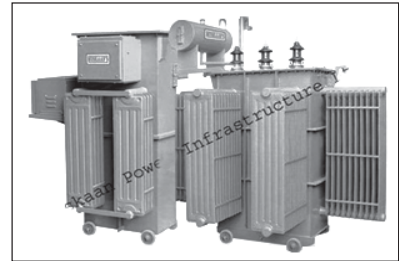

Contact:

**Muskaan Power Infrastructure Ltd**  
Sua Road, Industrial Area-C  
Dhandari Kalan, Ludhiana, Punjab 141 014  
☎ 0161 – 251 0641 • Mob: 94170 33948  
E-mail: [info@muskaanengineers.com](mailto:info@muskaanengineers.com)

## Worm Reduction Gearbox

Micro Precision Works is offering Worm Reduction Gearbox. The features are: its features are robust construction, increased efficiency, flexibility, interchangeability, compactness, durability and reliability; its fulfils a wide range of output RPM and horse power requirements; worm reduction unit are developed for heavy load works and power transmission with latest technology; these are also able to tackle many troubles like leakage, heating, worm damage, shaft bending, low efficiency; it has low provide high range of torque, flexible motor mounted in a convenient position; ensure high efficiency and low maintenance; extra cooling fan and heat transfer for improved efficiency. The company, founded in 1989, is engaged in manufacturing, supplying, and exporting a comprehensive collection of all types of gearboxes and conveyor accessories.



Contact:

**Micro Precision Works**  
Plot No. 207/A, Pushpam Industrial Estate  
Nika Tube Cross Road, Compound G.I.D.C  
Ahmedabad, Gujarat 382 445  
Mob: 99243 04636 | E-mail: [microgearbox@gmail.com](mailto:microgearbox@gmail.com)

## High Quality Pneumatic Printing Machines

Converge Transprint Systems offers High Quality Pneumatic Printing Machines. The features are: these are manufactured by highly skilled professionals from utmost quality components and latest technology, in sync with industry standards; it is closed cup type, user friendly operation, has minimum start up time and solvent consumption. It ensures clean working area and is environment friendly. It has 90 mm cup diameter; the max printing area is 85 mm. It prints on uneven surface and the maximum printing output is 1800 strokes per hour. It is microprocessor based and has pneumatic drive; and to maintain quality, the machines are tested on various quality parameters. The company founded in 2004, is engaged in manufacture and export of a wide range of printing machines, indexing tables and printing inks.



Contact:

**Converge Transprint Systems Pvt Ltd**  
F-27 Ground Floor, Sharad Industrial Estate  
Lake Road, Bhandup West, Mumbai 400 078  
☎ 022 – 2566 0252 • Mob: 93208 23985, 93215 21198  
E-mail: [transprint@vsnl.net](mailto:transprint@vsnl.net)

## Silicone Sealant

Join Leader Chemtech provides 550 Mirror Silicone Sealant. Their features are: it is a high modulus, neutral-curing, nor corrosive, weatherproof and anti-mildew sealant; known for its adhesion that provides a permanent flexible bond for mirrors to plaster, metal, or wood; mirror silicone sealant is mainly designed for bonding mirrors; it can also be used for anti-mildew and sealing of many materials, like glass, ceramic, etc.; it has application like mirror silicone sealant is ideal for mirror installations, bonding mirrors to painted surfaces, plaster, metal, or wood; mirror silicone sealant is also suitable for sealing, bonding, and mending tasks in car, boat, caravan, and houses; the product can be used on alkaline surfaces such as concrete, fibrous cement, mortar, asbestos and plaster. The company is a manufacturer and marketer of quality adhesives and sealants for last 17 years, serves industries like construction, automobile, DIY and other.



Contact:

**Join Leader Chemtech Private Limited**  
103, F.I.E, Chaudhary Charan Singh Marg, Patparganj  
Industrial Area, Patparganj, Delhi, 110 092  
Mob: 93111 45624 • E-mail: [sales@joinleader.in](mailto:sales@joinleader.in)

## Long Throat Depth Spot Welding Machine

Arm Welders Pvt Ltd are offering Long Throat Depth Spot Welding Machine. The features are: it is available in AC and 3-phase MFDC versions; it has a high-efficiency encapsulated transformer and a low-loss secondary circuit for maximum welding current; it includes sturdy RAM for high-speed operation; a safety cutoff switch for water flow in the transformer; and thyristors and an inverter. It enables 50 to 60% power saving with MFDC machines; its specifications include: AC rating - 100KVA to 150 KVA AC 2 phase; MFDC rating - 75KVA MFDC 3 phase; throat depth - 800 mm to 1200 mm; and nominal electrode force @ 5.5 bar - 350 kgs / 550 kgs; spot welding capacity - up to 2.5 +2.5 mm sheet; secondary current feedback controller. The company founded in 1978 under the visionary guidance. With the strong fundamentals of giving value and quality products, the company is catering to varied customer needs for over three decades and evolved as a strong quality brand in the domestic and international market.



Contact:

**Arm Welders Pvt Ltd**  
T- 96/2, MIDC, Bhosari  
Pune, Maharashtra 411 026  
Mob: 98220 39805 • E-mail: [sales@armwelders.com](mailto:sales@armwelders.com)

## Speed Reducer

MGM-Varvel Power Transmission offers a Bevel Speed Reducer. The features are: this bevel speed reducer has wide applications in various automobile parts and in other machinery; these speed reducers are available in various specifications and sizes; its features include: efficient working; high demand; high efficiency; main use: fractional and medium drives; manufacturing: 6 sizes, aluminium pressure die-cast up to size 3; grey cast iron from size 4 up, and three stages. The company, founded in 2011, is engaged as a provider of three phase asynchronous brake motors, one stage helical gearboxes, bevel helical gear boxes, planetary speed reducers, worm speed reducers, etc.

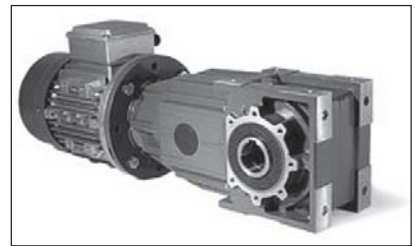

Contact:

**MGM-Varvel Power Transmission Pvt. Ltd.**  
S.No. 308/43, PLOT No. 6, VGP Industrial Complex  
Taluk Chettipedu, Sriperumbudur, Tamil Nadu 602 105  
☎ 044 – 6568 1815, 6462 7008  
Mob: 87544 70747 • E-mail: [info@mgmvarvelindia.com](mailto:info@mgmvarvelindia.com)

## Arc Welding Machine

Cruxweld Industrial Equipments offers Heavy Duty Stud Type Arc Welding Machine. The features are: the welding machines are compact, portable, highly effective, energy saving, resistant to voltage fluctuation and stable welding current; on-off switch control, current control and current indicator provided on the front panel, special design provides for excellent dynamic characteristic and ensures smooth and optimum metal transfer; light weight and compact transformer with robust construction – ideal choice for the site usage, excellent welder friendly due to high tech transformer design; reliable dynamic output; applicable for welding all kind of ferrous metal such as low carbon steel, medium carbon steel and alloy steel, etc. The company founded in 1997, are listed as the most renowned ISO 9001:2008 certified manufacturer, distributor, supplier and exporter of a comprehensive assortment of various welding machines and plasma cutting machines.



Contact:

**Cruxweld Industrial Equipments**  
5, Sector 29, Faridabad, Haryana 121 008  
Mob: 88008 82983 • E-mail: sales@cruxweld.com

## Socket Screws, Countersunk

Canco Fasteners offers Socket Screws, Countersunk. The features are: that these countersunk socket screws are manufactured in a comprehensive assortment; they are available in various sizes, shapes, grades, and materials; they are manufactured using advanced technologies in modern manufacturing facilities; quality norms are followed in accordance with international standards; they are produced from quality raw materials and have remarkable tensile strength; and they are appreciated for their corrosion resistance and long service life. Some of its advantages include remarkably tempered screws, and superb thread. The company, which was founded in 1987, is a manufacturer and exporter of fasteners and related hardware. Their product range includes heavy-duty anchors, general fixing anchors, light fixing anchors, self-drill anchors, pipe clamps, and many more.



Contact:

**Canco Fasteners**  
B-6/2, Safderjung Enclave, DDA Commercial Complex  
New Delhi 110 029  
☎ 011 – 4252 5500 • Mob: 98110 63537, 98113 15315  
E-mail: canco@vsnl.com, info@cancofasteners.com

# Industrial Products Source



**will be available as e-magazine.**

**Up to December 2023**

**visit : [www.ips.co.in](http://www.ips.co.in)**

## Control Cables

HPL Electric and Power Ltd offers Control Cables. Features: Range – 1.5 and 2.5 sq mm up to 37 core, 1100 volt grade conforming to IS: 1554-1/1988 and IS 7098-1/1988; Solid/Stranded 100% pure annealed Electrolytic copper conductor; Insulation PVC/XLPE/HR; Armoured/Unarmoured – GI Round wire/Flat Strip; Outer Sheath PVC (ST-1 and ST-2)/FR-LSH/FR/ZHFR; Heavy Duty Performance; Best combination safety; Efficient and economical; Use in Process Control, Communication and Panel control. The Company's other products range includes: Domestic and Industrial Wires; Co-axial Cables (CCS and CU), Submersible Cables; Multi-core Flexible Cable as per IS:694/2010; Telephone Cables, Instrumentation Cables, Networking Data Cables, Fire Alarm and Fire Survival Cables, Flat Elevator Cables, CCTV Cables, DC Solar Cables, etc.



Contact:

**HPL Electric and Power Ltd**  
Windsor Business Park, B-1D, Sector 10  
Noida, Uttar Pradesh 201 301  
☎ 0120 – 465 6400 • Fax: 0120 – 465 6333  
E-mail: hpl@hplindia.com

## Anti-spatter Polyurethane Tubes

Vijay Air Control provides a wide range of Anti-Spatter Polyurethane Tubes -new generation - PNU-VO Series. The features are: it is ultra softness enables to display excellent efficiency in piping; outstanding anti-weather, anti-curve and anti-fatigue properties; it is suitable for welding applications also available OD: 6, 8, 10 and 12mm; available colours: blue, yellow, black, red, green, and white; customised colours available on request with minimum order quantity. The company is one large workplace where work is done and then put on the market in the form of products and services. This work must be benefit if it is to hold its own in the face of competition. Only a company based on sound economic, technical and organisation principles and which is in a position to have a say in future developments is a match for the challenges presented by the market and competition.



Contact:

**Vijay Air Control**  
44/A, 59th 'A' Cross, 4th 'N' Block  
Rajaji Nagar, Bangalore, Karnataka 560 010  
☎ 080 – 2314 8871, 2314 1136  
Mob: 89511 01436, 98806 52082  
E-mail: saivacblr@vacpneumatic.co.in

## Digital Pulse Mig Welding Machine

Fusion Resources offers Digital Pulse Mig Welding Machine. The features are: a 400 amps output rating that allows better welding quality and improves productivity; high-grade welding with GT pulse control; a user-friendly touch panel and remote control; high precision wire feeding quality with encoder feedback function; a cable-less remote control that ensures high mobility; being built to operate in touch conditions and on all types of work-sites; and faster service support across India. The company was founded in 2006, and specialises in trading and supplying a highly reliable assortment of arc welding machines, welding robot systems, MIG and MAG welding machines, TIG welding machines, air plasma cutting machines, and welding torches.



Contact:

**Fusion Resources**  
93, 6, GIDC Road, Suresh Nagar-1, GIDC  
Makarpura, Vadodara, Gujarat 390 010  
☎ 0265 – 3098 176 | Mob: 98254 36895, 92272 00270  
E-mail: fusionresources@gmail.com, satyagrawal@gmail.com

## Solar Lantern

Unitop Power Electronics supplies a wide range of Solar Lanterns. Features are: a portable source of light that can be easily moved like a torch and can be kept anywhere without occupying much space; in fact, present day solar lanterns come in various decorative and aesthetic shapes that enhances look and feel of your house; there are widely used as emergency lights in the areas under frequent power shutdowns; and its features include environment friendly, portable, rugged and dependable, silent operation, light output 400 lumens, i.e., equivalent to a 40 W incandescent lamp, LED for battery status indication and its safeguard. The company manufactures and exports a range of power protection and power backup systems.



Contact:

**Unitop Power Electronics Pvt Ltd**  
Shop No: C-124, FFC, I-Area, Okhla Phase III  
Okhla Industrial Area, New Delhi 110 020  
☎ 011 – 2631 1484 • Mob: 99717 14511  
E-mail: ujwal@unitoppower.in

# Industrial Products Source

A Magazine for Indian Industries since 2004

## SPECIAL SECTION SCHEDULE - March 2023 to December 2023

March	2023	Chemical, Pharma, Bio-Tech & Food Processing, Packaging, Pollution Control Equipment
April	2023	Pumps & Valves, Pneumatics & Hydraulics, Chemical & Petrochemicals, Process Plant & Machinery
May	2023	ACME 2023 Exhibition + Focus: Machine Tools & Automobile Accessories
June	2023	Foundry Equipment, Casting, Forging & Shot Blasting, Boilers & Furnaces
July	2023	Industrial Automation, Instrumentation, Testing & Measuring Instrument
August	2023	Gears & Bearings, Motors & Drives, Clutches & Brakes, Oils & Lubricants
September	2023	Pumps, Valves, Tubes & Pipe Fittings
October	2023	Material Handling & Storage Equipment
November	2023	Electrical & Electronics, Solar, Wind & Alternative Energy
December	2023	20 <sup>th</sup> Annual Issue



### Area of Circulation (Industry wise)

- Agriculture
- Air Condition
- Airlines & Aerospace Industries
- Atomic Sector
- Automation
- Automobile
- Bio-Tech & Pharmaceuticals
- Boilers
- Banking Sector
- Cement
- Ceramics
- Chemical Plants
- Construction Machinery & Equipment
- Defence
- Electrical & Electronics
- Exporters
- Fasteners
- Fertilizer
- Food & Beverage
- Foundry & Forgings
- Heat Exchangers & Cooling Towers
- Heavy Engineering
- Hydraulics & Pneumatics
- Industrial Safety & Security
- Libraries
- Machine Tools
- Material Handling
- Oils & Refineries
- Paints
- Paper & Pulp
- Petrochemicals
- Plastic & Rubber
- Pollution Control Boards
- Printing & Packaging
- Project Consultants
- Pumps & Valves
- Railways
- Research Institutions
- Steel
- Sugar / Tea
- Testing Laboratories
- Textiles
- Universities
- Welding

### Advertisement Tariff

Size	4-Color	Black & White
Full Page (17.5 [W] x 25 [H] cm)	₹ 21,000/-	₹ 14,000/-
Half Page (H-17.5 [W] x 12 [H] cm) (V-8.5 [W] x 25 [H] cm)	₹ 12,800/-	₹ 8,500/-
Quarter Page (8.5 [W] x 12 [H] cm)	₹ 7,200/-	₹ 4,800/-
Double Spread (35 [W] x 25 [H] cm)	₹ 42,000/-	₹ 28,000/-
<b>Cover Pages</b>		<b>4 - Color</b>
Front Cover-Half Page (H)		₹ 24,000/-
Front Cover-Quarter Page		₹ 15,000/-
Front Cover-Strip (H) (17.5 [W] x 6 [H] cm)		₹ 15,000/-
Front Inside Cover		₹ 27,000/-
Back Inside Cover		₹ 27,000/-
Back Cover		₹ 32,400/-
Front Gate Fold		₹ 54,000/-

Home Page	3-Months	6-Months
Small Banner (100 x 100 pixels)	₹ 6,000/-	₹ 10,000/-
Large Banner (240 x 100 pixels)	₹ 8,000/-	₹ 14,000/-

Inclusive of Design & Hosting - 12 kb maximum  
 If the advertiser wishes to change the design or any updating in the banner will be charged extra

	Subscription Charges
1-Year (12 Issues)	₹ 300/-
2-Year (24 Issues)	₹ 550/-
3-Year (36 Issues)	₹ 750/-

Outstation payment should be at par cheque/DD drawn in favour of "Product News Publication" only

Trim Size: 28 [H] x 21 [W] cms; Bleed Size: 28.6 [H] x 21.6 [W] cms Material Requirement: CorelDraw or PDF Files



Editorial, Circulation & Marketing Office

**Product News Publication**

104, Sudama Yash, Nr: Ramkrishna Hotel, Kelkar Cross Road, Ram Nagar, Dombivli (E), Thane 421 201

E-mail: ipsmaginfo@gmail.com / ipsmag@yahoo.com

Visit: [www.ips.co.in](http://www.ips.co.in) / [www.industrialproductssource.com](http://www.industrialproductssource.com) to view our e-magazine

## Industrial Milling Machines

Daljit Machines offers Industrial Milling Machines. The features are: these machines are worked to create shapes and sizes and operated in all kinds of industries; the size, power and built quality of milling machines vary a lot, so choosing any one of them from the machine dock range is quite important to have that precise efficiency; the milling machine has got a cutter installed that makes it operate multi-purposefully on milling and turning materials. Also, it helps in removing the material from the surface of the work piece; a milling process involves cutting tools like the end mills which have special cutting surfaces. The cutters made from highly resistant materials have extended cutting surfaces that produce less friction. The company has for the last four decades manufactured and exported machine tools. It has established itself to be exceptionally good in production, supplying and exporting of industrialised machine products.

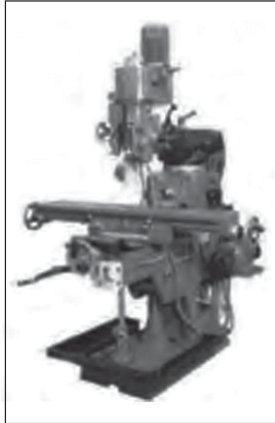

Contact:

**Daljit Machines**

Street No. 7, Opp. Power House

New Janta Nagar, Ludhiana, Punjab 141 003

☎ 0161 – 5099 009 • Mob: 98786 09009, 85349 00009

E-mail: sales@daljitmachines.com

## Robot Simulation and offline Programming

Difacto Robotics and Automation offers Robot Simulation and Offline Programming. The features are: Robot simulation and off-line programming (OLP) form the core of digital manufacturing technologies; they provides simulation and OLP services for robot based automation systems that enable: robot placement and layout optimization, Cycle time optimisation, reachability studies and interference checks, design validation (fixtures, weld guns, grippers, tools, material handling equipment, and others),etc. The company offers turnkey industrial automation systems and solutions with industrial robots. With its passion for excellence and concentrated focus on customer requirements, they has transformed itself from a small startup to an established technology partner to various renowned clients across India and the world.

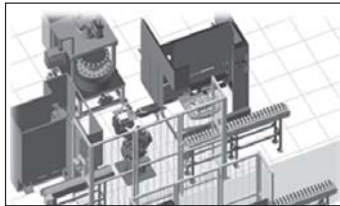

Contact:

**Difacto Robotics and Automation Pvt Ltd**

Plot No. 103, 113, 114, 7th Main, 3rd Cross Road

3rd Stage, Industrial Area, Bengaluru, Karnataka 560 058

☎ 080 – 4212 0041, 2837 2040

E-mail: info@difacto.com

## Blasting System for Roll Etching

Surface Finishing Equipment Company provides a wide range of Blasting System for Roll Etching. The features are as follows: the machine is based on the pressure blasting principle. The rolls are placed on two rotating stations (two headstock and two tailstock arrangements) in this machine. You can use one large roll of 6 metres or two small rolls of 3 meters. The rotating station will have a chuck and tailstock type system on which the job is placed and rotates; the job loading and unloading will be done from the top, which reduces the overall space requirement of the machine. The machine is equipped with a nozzle reciprocation system (VFD controlled). Two No. of nozzle will move forward and backward on two blasting station by motorized Carriage Trolley arrangement through lead-screw/Chain sprocket type system. Encoders will be provided to control the stroke length of the reciprocation system through HMI/control panel as shown in GA drawing; the Roll will rotate on its axis (VFD controlled drive) and the Nozzle by the reciprocating arrangements will move forward and backward and clean the Roll uniformly from outer periphery. At a time 2 nos Roll of 3 mtr length can blast at two stations; the spent abrasive is collected in bottom hopper of the cabinet from where it will falls down into the screw conveyor unit, where it is conveyed by longitudinal screw conveyors. The screw conveyor conveys the abrasive media into the boot of the bucket elevator. The bucket elevator lifts the media and pours it into the Air Wash media separation unit, where the reusable abrasive goes into the blast generator and the abrasive is recycled through the blast nozzle. The abrasive is transferred to the blast generator when the mushroom valve for filling the media into the blast generator is opened. The blast generator will be briefly depressurized in order to open the mushroom valve. The mushroom valve gets closed when compressed air is switched on and the abrasive storage tank gets pressurized, allowing the free fall of abrasive into the mixing tube. From the mixing tube, the abrasive is carried away by compressed air to the nozzle for blasting. A sufficient capacity of dust collectors is incorporated to suck up the dust produced in the blast chamber and keep the chamber and environment clean. The company was founded in 1977 and is the oldest manufacturer of shot blasting machines in India. Since then, it has delivered more than 6000 shot blasting and peening machines.



Contact:

**Surface Finishing Equipment Company**

E-100, M.I.A., Phase-II, Basni

Jodhpur, Rajasthan 342 005

☎ 0291 – 274 0128, 274 0259 • Mob: 98290 22624

E-mail: sfecjodhpur@gmail.com, surfacefinishing@yahoo.com

## Stretch Wrappers

Millenium Packaging Solutions offers Stretch Wrappers. The features are: it is offered efficiency, strength, longer service as well as longer working life; it is PLC controlled (optional); power pre-stretch system supplying up to 300% stretch; all AC motor with frequency inverter control; photo eye pallet height sensor; photo eye sensing delay; film tension control adjustment; and it has a separate start/reset/emergency stop button; soft start/soft stop; heavy duty chain drive. The company founded in 2000 is engaged in manufacturing, supplying, distributing wide range of strapping, sealing and packaging machines.



Contact:

### Millenium Packaging Solutions

132, Mohammadpur, Bhikaji Cama Place, New Delhi 110 066

☎ 011 – 2610 6352 • Mob: 98730 01434, 99909 88210

E-mail: sales@milleniumpackaging.in

## Piping Thread Sealant

Glue Farm (India) Pvt Ltd provides a diverse selection of Piping Thread Sealant. The features are: this piping thread sealant is an effective solution for leaking pipes; it is wide-



ly used for sealing metal pipes and fittings; it is processed using the finest quality chemical compounds under the vigilance of skilled professionals; and it is inspected by quality experts with a series of testing procedures for quality. It is reasonably priced, and some of its advantages include the prevention of fretting corrosion, quick bonding, and a long shelf life. The company, which started in 2011, is a manufacturer and supplier of locking adhesives and sealants. The range is made up of products like silicone sealants, retaining adhesives, and structural adhesives. These products with a longer shelf life are manufactured following the established industry norms and guidelines, utilising the finest raw materials and modern machines.

Contact:

### Glue Farm (India) Pvt Ltd

No. 16, 5th M16, 5th Main Road, Chikka Adugodi  
Tavarekere Main Road, Bengaluru, Karnataka 560 029

☎ 080 – 2550 4889 • Fax: 080 – 2552 1385

Mob: 96118 71123 | E-mail: info@gluefarm.in

## PAC/DC Welding Machine

Modi Arc Electrodes Company offers a TIG 500 PAC/DC Welding Machine. The features are: the high frequency 20KHz inverter technology provides lightweight, small volume, and energy savings, significantly reducing the customer's running cost; the advanced IGBT and fast recovery diode module combine with upgraded circuitry to provide longevity and reliability;



the effective protection circuitries against various damaged risks such as lack of phase, overload of voltage or current, voltage shortage, and overheating deliver high reliability during operation; as a versatile, multi-purpose, multi-process welder, this has the adaptive features of crater, repeat, pulsed TIG, spot TIG, DC TIG, mixed AD/DC TIG, etc. The company, a well-known entity incepted in 1962, is a prominent manufacturer and supplier of a qualitative assortment of deep penetration electrodes, mild steel electrodes, low hydrogen/low alloy steel electrodes, etc.

Contact:

### Modi Arc Electrodes Company

Suite No. 601, 6th Floor, Copia Corporate Suites 9

Jasola Commercial Complex

Jasola Vihar, New Delhi 110 025

Mob: 83938 89192 | E-mail: infodelhi.modiarc@groupmkm.in

## Trouble Free Performance Hydraulic Cylinder

Hydraulic Force Enterprises offers Trouble Free Performance Hydraulic Cylinder. The features are: these cylinders are practical and assure long, trouble free performance and minimum maintenance; cylinders are available in a variety of constructions that meet international standards, like tie rod construction, welded construction, one-piece construction, bolted type, threaded head, low lift, high lift, and telescopic construction; piston rod made out of EN-8 & EN9 material duly machined, ground, hard chrome plated and re-ground up to high polish. Cast iron pistons are also available; seals are provided, i.e., a rod seal, a rod wiper seal, and a tube seal, for a sealing arrangement that assures low friction and a trouble-free life; and tie rods are made out of medium-carbon steel that is pre-stressed at assembly to minimise the possibility of elongation. The company, which started in 1996, is engaged in manufacturing and supplying high-grade hydraulic and scientific machines and equipment.



Contact:

### Hydraulic Force Enterprises

Plot No. 101, Pocket G-21, Sector-7, Rohini, Delhi 110 085

☎ 011 – 2876 5987, 2876 1718

E-mail: hydraulicforce3@gmail.com

## HT Switchgear Panel

GSS Powerserve offers a wide range of HT Switchgear Panels. Features are: It is reliable in operation; low maintenance; superior functionality; manufactured using premium quality raw material; highly efficient, easy to maintain, smooth functioning and optimum quality; vacuum circuit breaker panels up to 36 kV; SF6 gas insulated vacuum ring main units (including add-on units) in various combinations (multi circuit range) as per customer requirement up to 24 kV; oil RMUs; outdoor VCBs up to 36 kV; indoor GIS panels up to 36 kV; retrofit solutions for old bulk oil circuit breakers (replacement of BOCB trolley with retrofit VCB trolley); SF6 gas circuit breakers 36 kV, 66 kV, 110 kV, 230 kV. The company is supported with well qualified and highly experienced professionals with 20 years' experience in the field of power quality audits and offer suitable solutions.



Contact:

**GSS Powerserve Private Limited**  
Popular Garden, 5/29 Barathipuram  
Coimbatore, Tamil Nadu 641 103  
Mob: 75024 59382 • E-mail: sales@gsspowerserve.in

## Robotic Machine Tending

Synetics Automation Solutions offers Robotic Machine Tending. The features are: these products provide specialised robotic machine tending solutions; if the components are heavier and different operations are performed on a combination of one or more CNCs or CNCs and a VMC, then robotic systems are the choice; robotic systems are also more flexible when compared to stand-alone autoloader and gantry systems; this is system integration for robotic cells with the following: infeed and outfeed systems such as slat chain conveyors, rotary tables, belt conveyors and bin feeders; orientation fixtures and intermediate inspection stations; safety systems with interlocking gates; complete interfacing with CNC machines; the machining process has to be stable and the manual intervention for offset corrections and insert changes has to be minimal to achieve maximum productivity. The company founded in 2010, is a provider of industrial automation and robotic solutions.

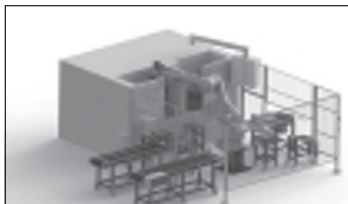

Contact:

**Synetics Automation Solutions Pvt Ltd**  
No. 410/2, Nehru Nagar West, Tex Park Road  
Coimbatore, Tamil Nadu 641 014  
Mob: 87540 66025 • E-mail: sales@synetics.co.in

## Hydraulic Fittings

Supreme Engineers offers a wide range of Hydraulic Fittings. These fittings are precisely manufactured to withstand vacuum, pressure, and hydraulic fluids used in the system. To make them suitable for most hydraulic applications, these are available in different dimensions and sizes at affordable prices. Its features include sturdiness, a flawless finish, and rust resistance. These products are designed at a sophisticated manufacturing unit using supreme-quality raw materials and the latest technology in compliance with set industry norms; the raw materials are procured from reputed vendors of the market, and tested on various parameters before further processing. The company, established in 2006, manufactures a wide range of CNC precision components, hydraulic fittings, triple screw pumps, and SS fittings. These products are available in different specifications and can be customised as per the requirements of the clients.



Contact:

**Supreme Engineers**  
7, Techno Industrial Estate, Behind Wonder Point Complex  
C T M Road, Amraiwadi, Near Shreeji Dairy  
Ahmedabad, Gujarat 380 026  
Mob: 98796 11703 • E-mail: supremeahmedabad@yahoo.com

## Transformers & Chokes, Inductors & Reactors

Salzer Electronics Limited offers Transformers and chokes, Inductors, and Reactors. Dry Type Magnetics – VPI, AN- AF Water Cooling etc; Transformers Range: 1 kVA to 1 MVA, 1 phase and 3-phase. Chokes/Inductors/Reactors Range: 1 kVAR to 1 MVAR, 1 phase and 3-phase. Applications: Voltage step-up and Step-down, Isolation, Power factor Correction, Harmonics Filtering, Current/Power smoothening, etc. Sectors: Renewable Energy (UPS/Wind/Solar), Drive sectors, Industrial Sectors and Railway/Traction/Mobility, etc. The Company also offers Energy Savers and Panels, Modular Switches, Limit and Foot Switches, Wires and Cables, Wire Harness and Power Cords, Enameled Copper Wires and Polywrap Wires, Rotary Switches (AC/DC), Photo Voltaic Isolators, Cable Ducts, Contactors and Overload Relays, etc.

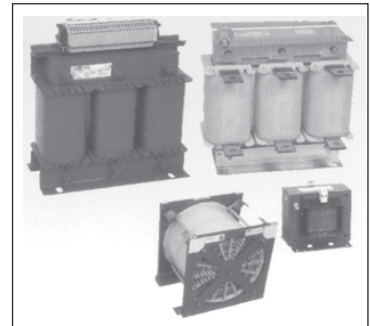

Contact:

**Salzer Electronics Limited**  
Samichettipalayam, Coimbaore, Tamil Nadu 641 047  
☎ 0422 – 423 3600 • Fax: 0422 – 269 2170  
E-mail: salzer@salzergroup.com



## Wood & Coal Fired 1000 Kg/Hr Packaged Steam Boiler

Heat Max Engineering Wood & Coal Fired 1000 Kg/Hr Packaged Steam Boiler. The features are: a boiler is an enclosed vessel that provides a means for combustion heat to be transferred into water until it becomes heated water or steam; the hot water or steam under pressure is then usable for transferring the heat to a process. Water is a useful and cheap medium for transferring heat to a process; the boiler system consists of: feed water system, a steam system, and a fuel system. The feed water system provides water to the boiler and regulates it automatically to meet the steam demand; throughout the system, steam pressure is regulated using valves and checked with steam pressure gauges; its features include: fully automatic; excellent performance; longer service life; low maintenance; and rugged construction. The company is a manufacturer of industrial thermic fluid heaters, industrial steam boilers, and hot water generators.



Contact:

**Heat Max Engineering**  
Plot No. 5-6, Khodiyar Estate  
Behind Indo German Tool  
Ahmedabad, Gujarat 382 445  
☎ 079 – 2584 0215 • Mob: 98240 52714  
E-mail: hmevipul@yahoo.com

## Axial Flow Fans

Air Mech Industrial Technologies provides a wide range of Axial Flow Fans. The features are: they manufactured with high-grade aluminium alloys and stainless steel, housed on either mild or stainless steel casing, with direct and belt driven options; some of its advantages are that of quick and easy installation, robust design, high efficiency and precise air flow, oil free and clean air operation, low noise levels, minimum moving parts, and low and simple maintenance, and the range of axial flow fans caters from micro establishments to major manufacturing facilities, small shops to malls, from metal processing plants to pharmaceutical industry. The company is a solution provider for attaining efficient working environments in various industries.



Contact:

**Air Mech Industrial Technologies**  
12, Golani Industrial Estate, Waliv Road  
Dewan And Shah Udyog Nagar, Golani Naka  
Vasai East, Waliv, Palghar, Maharashtra 401 208  
Mob: 92222 20996 • Mob: info@airmech.in

## Pipe Sealant

Hibond Adhesives (India) offers a wide range of Pipe Sealant. The features are that: a skilled team of professionals has developed this pipe sealant in an extensive range; it is formulated with the help of quality chemical compounds and modular machines in compliance with set industry standards; and it is used for sealing pipes and metal fittings. Sealant is strictly checked on different quality parameters, assuring its flawlessness at the user's end; and some of its benefits include affordability, temperature resistance, and great results. The company is a manufacturer and supplier of industrial adhesives, for over 20 years, it has grown from strength to strength in the Indian market and international markets by virtue of being one of the largest importers and exporters of industrial adhesives.



Contact:

**Hibond Adhesives (India) Pvt Ltd**  
Door No. 29, Rukmini Sandesh, 29 - A, Friends Colony  
Bhandup East, Mumbai 400 042  
☎ 022 – 2564 3003 • Fax: 022 – 2564 5657  
Mob: 93211 21315 • E-mail: info@hibondadhesives.com,  
sales@hibondadhesives.com

## Petrol Power Backup Generator

Delhiwala Zaheeruddin Jamaluddin offers a wide range of Petrol Power Backup Generator. The features are: further, these petrol driven emergency power backup generators can also be made available in different power capacity choices to pick; it allows minimum fuel consumption which makes it economical to use, low operation noise level, high quality performance support and powered by 4-stroke gasoline engine; these are equipped with large capacity fuel tank for long service life, steady output and easy operations, widely used as an emergency power supply solution, rated AC voltage of 110/220/230/240V and has start method recoil starter. The company started in 1990, is a manufacturer, wholesaler, service provider and traders of premium quality diesel generator sets and accessories.

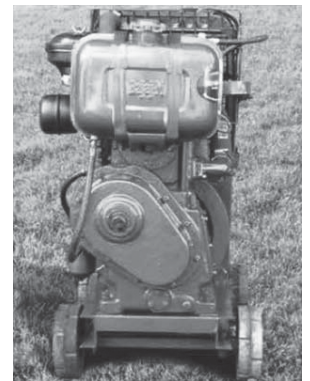

Contact:

**Delhiwala Zaheeruddin Jamaluddin**  
No.159, 4th Lane, Darukhana, Reay Road  
Mazgaon, Mumbai 400 010  
☎ 022 – 2371 2013 | Mob: 91674 68837, 98210 55088  
E-mail: delhiwalazi@yahoo.com

## Solar Hot Water System

Haadi Enterprises offers a wide range of Solar Hot Water System. The features are: this solar hot water system has applications in both domestic and commercial areas; manufactured using latest technology in compliance with international quality standards; the heater makes use of solar energy, heat waters to a very high temperature and it remains for a long time; contains an insulated tank and collector support structure with inner coating of layers of copper, stainless steel and aluminium, which helps in heating water to a very high temperature, and the system is cost efficient, environment friendly and the powder coating provides double protection against harsh climate conditions. The company founded in 2007, is a leading manufacture, trader and supplier of solar equipment, water heaters, hot water systems and much more. They offers a quality range of solar products, with a team of professionals and advanced machinery to manufacture superior quality products.



Contact:

**Haadi Enterprises**

**#44, 1st Main Road, Manorayanapalya New Extension**

**Dinnur, RT Nagar, Bengaluru, Karnataka 560 032**

**Mob: 98451 58011, 96206 38110**

**E-mail: haaditnerprises1109@gmail.com**

## Stainless Steel Pulverizers

Sree Valsa Engineering Company offers Stainless Steel Pulverisers. The features are: these machines are used in pharmaceutical and food industry. Their expert manpower manufactures these machines in compliance with set industrial norms using best-quality stainless steel; leveraging upon their technical know-how, they are engaged in manufacturing and exporting an exclusive range of stainless-steel pulverisers; highly demanded among clients, these stainless-steel pulverisers are available in different specifications for clients; and their features include a rust proof structure, being easy to install and maintain, and having a high working efficiency. The company is the pioneer manufacturer and exporter of food processing equipment, and machinery in India.

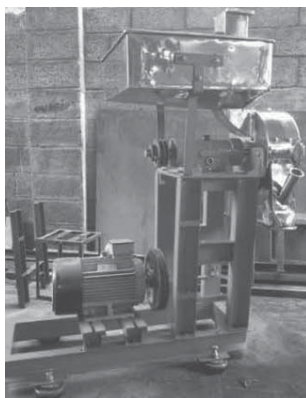

Contact:

**Sree Valsa Engineering Company**

**261, Nandha Nagar Road, Singanallur, Tamil Nadu 641 005**

**Mob: 98430 12172 • srvlsn@yahoo.com**

## Safety Bump Cap to Protect at Work

Tej Engineering offers Safety Bump Cap to protect at Work. The Surfex Scarf safety bump cap has profited from its development to become one of the safest and secure products of its type on the world market. Features: All Season – water repellent and breathable material inner anti sweat band for additional comfort and coolness reflective band for high visibility. Ergonomic Shell Specially developed for its lightness, comfort, dynamic design and ease of insertion into the cap. Detachable EVA aerated protective foam for ease of replacement or cleaning. 5 LED light on the front of the cap, with CR2032 batteries supplied provided with or without the protective shell. Due to the micro perforations the shell is well ventilated.



Contact:

**Tej Engineering Pvt Ltd**

**Unit No: 450, Edison Building No: 1, TTC Industrial Area**

**MIDC, Juinagar, Navi Mumbai 400 705**

**☎ 022 – 2087 1071, 2087 1072**

**E-mail: mumbai@tejengineering.com**

## CNC Router Machine

Mengi Engineering Company offers CNC Router Machines. Specifications of SM 6090 Power – Work table size: 600 mm x 900 mm x 120 mm; Table: T-slot combined table; Frame: Cast Iron; X, Y, Z Drive system: X, Y, Z ball screw; Max Rapid: 20 m/min; Max working speed: 15 m/min; Positioning accuracy:  $\pm 0.05$  mm; Working accuracy:  $\pm 0.1$  mm/300 mm; Spindle power: 3.5 kW; Spindle rotary speed: 24000 RPM; Power motor: Stepper motor; Voltage: AC 380 V, 50/Hz, 3 HP; Command language: G code; Control: DSP hand shank; Software: ART-CAM; Weight: 900 kg; Max travel speed: 15000 mm/min; Max working speed: 10000 mm/min; Working precision: 0.05 mm; Repeatability precision: 0.01 mm.



Contact:

**Mengi Engineering Company**

**Plot No: A/232, Road No: 21, Y Lane**

**Wagle Estate, Thane 400 604**

**☎ 022 – 2582 3203 • Mob: 97699 76747**

**E-mail: audatechindia@gmail.com**

## DeburringEXPO – the Industry Meet for Deburring and Finishing

Requirements and processes are changing in many ways for the manufacturing industries as a result of structural and technological change. Where deburring and the production of precision surface finishes are concerned, this results in the need for new and modified solutions. The 5th DeburringEXPO will present innovations and trends for these production steps, which are becoming increasingly relevant for quality and efficiency, at the Karlsruhe Exhibition Centre from the 10th through the 12th of Oc-

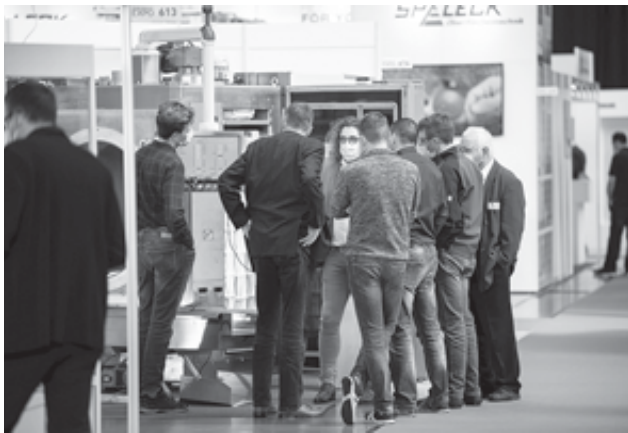

Its clear focus on the production steps involving deburring, rounding and the production of precision surface finishes makes DeburringEXPO the ideal presentation platform for current and new solutions

tober, 2023. This makes it an absolute must for industry players in order to exchange information with interested parties and customers about their investment plans. With its bilingual expert forum, the leading trade fair for deburring technologies and precision surface finishing also hosts one of Europe's most coveted sources of knowledge.

Its clear focus on deburring and edge rounding, as well as the production of precision surface finishes, has made DeburringEXPO the leading trade fair in Europe for these manufacturing steps. It's a must-attend event for companies from the industry sector, and its dates are firmly anchored in the trade fair calendar. This hardly comes as a surprise, because international expert visitors always arrive at the event with concrete tasks, RFQs and projects, for which efficient solutions are being sought. This was confirmed amongst others by Iris Münz, commercial director of Ultratec Anlagentechnik Münz GmbH, after participating at the last event in 2021: "We were pleasantly

surprised – not only by the number of leads, but rather by their quality as well. Visitors came to us with very precise requirements for specific components." Furthermore, a very high proportion of the participating expert visitors are involved in operational investment decisions, i.e. an average of about 95% at each and every DeburringEXPO.

### The Ideal Information Platform for All Industries and Materials

Beyond this, the exhibition portfolio of the leading trade fair for deburring technologies and precision surface finishing covers processes that are also becoming increasingly important in parts manufacturing throughout all industry sectors. "Companies are being confronted with ever-stricter or modified and new

requirements, where previously used processes and technologies are reaching their limits. For example, these include more demanding specifications for surface quality, more complex component geometries and a changing component spectrum, as well as new and modified materials and manufacturing processes," reports Hartmut Herdin, managing director of private trade fair promoters fairXperts GmbH & Co. KG. Additional factors involve process automation and digitalisation, which not only ensure the reproducibility required for many applications, but can also alleviate the shortage of skilled personnel. Not least of all, climate protection, the efficient use of energy and resources and cost optimisation in parts production are becoming increasingly important as



DeburringEXPO is the Europe-wide meeting place for parts manufacturers from all industries who are seeking solutions for their requirements

# Company News

competitive factors. DeburringEXPO covers this range of requirements in a targeted, thematically specific manner. It provides a complete overview of up-to-date, innovative solutions, shares information on current trends in various industries and offers insights into research projects. And thus the leading trade fair for deburring technologies and precision surface finishing creates an ideal environment for the presentation of current and new solutions, for early technology monitoring, and for the establishment and expansion of partnerships and networks. As of the end of January, these convincing arguments had already prompted 70 companies to make firm booth space bookings – including almost all market and technology leaders. “Based on numerous enquiries and reservations, we’re expecting 150 to 180 national and international exhibitors, which is a significant increase as compared with the last event in 2021 and almost matches pre-corona levels,” adds Gitta Steinmann, DeburringEXPO project manager.

## Supplementary Programme with Theme Parks and Expert Forum

With theme parks covering the issues of “Component Cleaning”, “Quality Control” and “Automation”, the supplementary programme at the upcoming DeburringEXPO will focus on three aspects that specifically contribute to meeting current and future requirements for component surface quality.

The integrated 3-day expert forum at DeburringEXPO with simultaneously interpreted presentations (German <> English) is one of the most sought-after sources of knowledge anywhere in Europe. It enables visitors to enhance their know-how in the fields of deburring, rounding and component cleaning, as well as in the production of precision surface finishes, by presenting new solutions, research results and benchmark applications.

Further information, please contact:

Website: [www.deburring-expo.de](http://www.deburring-expo.de)

## Industrial Products Source

**A technical magazine useful for:**

**Industries, Libraries, Technical Institutions Polytechnics,  
Engineering Colleges etc.**

**20<sup>th</sup>  
YEAR OF  
PUBLICATION**

### Subscribe Now:

For 1 year (12 issues)	Rs. 300/-
For 2 years (24 issues)	Rs. 550/-
For 3 years (36 issues)	Rs. 750/-

The issues are available as e-Magazine also. Visit: [www.ips.co.in](http://www.ips.co.in)

### Product News Publication

104, Sudama Yash, Kelkar Cross Road, Ram Nagar  
Dombivili (E), Thane 421 201  
Mob: 98206 70855 / 98208 38998  
E-mail: [ipsmag@yahoo.com](mailto:ipsmag@yahoo.com) / [ipsmaginfo@gmail.com](mailto:ipsmaginfo@gmail.com)

## LMW at IMTEX 2023

The engineering conglomerate, Lakshmi Machine Works Limited started its value driven machine tool division in 1988 to produce finest range of CNC Machines. The journey of LMW was established in 1962 to provide Indian textile mills with the latest spinning technologies. Today, LMW is a leading textile machine manufacturers in India and one among the three in the world to produce entire



range of textile spinning machinery. LMW's foundry makes precision castings for industries worldwide. The company has added an Advanced Technology Center to manufacture components for the Aerospace industry.

The machine tool division has developed the own capability to design and manufacture world class CNC turning and machining centers. The high precision mother machines coupled with skilled people produce high quality



products. We made a substantial investments on manufacturing facilities, which brings technological competence that address the global market. A dedicated spindle assembly make spindles upto 24000 rpm. They make different spindles like, belt driven, direct driven and built-in motor spindle. These spindles undergo spindle run testing, spindle dynamic balancing. All the assembly lines are dust-free and temperature controlled to ensure maximum accuracy.

We at LMW, focuses on major demanding factors in the



market 1) Accuracy & long lasting repeatability 2) Reliability 3) Reduction in cycle time 4) Low cost per component 5) High productivity.

LMW launched and displayed some of our latest machines in turning, milling and turnmill centers at IMTEX 2023 being held at BIEC, Bengaluru from 19<sup>th</sup> to 25<sup>th</sup> January 2023.

LMW has launched, S Turn I, The state-of-art turning machine has maximum turning dia of 320 mm, maximum turning length of 400 mm. The machine comes with 8 station hydraulic turret, spindle speed of 4500 rpm, spindle power of 5.5/ 7.5 kW. The machine has interfaced with gantry automation. High speed positioning keep non-cut time to the minimum. The machine is suitable for Aerospace, Automobile, Defence and General Engineering.



Gigaturn I, an optimal large dia turning center with maximum turning dia of 510 mm and maximum turning length of 640 mm. The machine comes with 12 stations turret, rigid fixture for stable turning, customized EOS screen. It has wide chip disposal area for easy maintenance. The machine is suitable for Automobile, Pumps & Valves and Oil & Gas.

JD-1, a precision machine. It has direct drive spindle BBT 30, with speed upto 24,000 rpm. The machine has rigid structure with wider working area, it is ergonomically de-

# Company News

signed for easy loading and unloading operations. The machine comes with faster tool change time of 1 sec. It is designed for high speed machining for materials such as Aluminum and special aluminum alloys. The machine be suited for components for electronic segments such as mobile case, laptops and tablets.

We have also launched 2 machines from popular J series Vertical Machining Centers. J6 R has rotary pallet changers which is a major requirement from many high volume production customers. It has a table size of 850 x 500 mm, spindle speed upto 10,000 rpm. It comes with 24 ATC tools. The machine is suitable for Automobile, Aerospace, Defence, Die & Mould, Pumps & Valves and General Engineering.

J8 – Heavy duty Vertical Machining Center, has a table size of 1200 x 600 mm, spindle speed of 6000 rpm and it has BT 50 tooling for heavy duty machining to meet the requirements of larger components. The machine is suitable for Automobile, Aerospace, Agri & Earthmovers, Die & Mould, Pumps & Valves and General Engineering.

JH 500 – State-of-art, horizontal machining center has 500 x 630 pallet size with pallet loading capacity of 500 kg. The machine comes with hydraulic rotary pallet changer. It has 40 tool station. This machine is suitable for Automobile, Pumps & Valves, Aerospace and General Engineering.

The company has established a pan India network of sales and services that cater to every industrial city in India. Machine tool division provides integrated solutions for various industrial needs in Automobile, Aerospace, Die & Mould, Defence, Pumps & Valves, Railways, Medical Equipment, Forging, General Engineering, etc. LMW also provides automation solutions such as simple loaders, Gantry systems, and Robots that are tailored to meet the customer requirements.

Contact:

**Lakshmi Machine Works Limited**  
**Machine Tool Division**  
**Arasur, Coimbatore 641 407**  
**E-mail: info@lmwenc.com**

## LANXESS Performance Materials showcases impressive range of high performance plastics at PLASTINDIA 2023

LANXESS Performance Materials, a leading global joint venture established between LANXESS and Advent International for high-performance engineering polymers is presenting a range of modern and light weight solutions with high-performance plastics for the automotive, two-wheeler and e-mobility industry at PLASTINDIA 2023 from 1<sup>st</sup> to 5<sup>th</sup> February. The company is also exhibiting select applications of high-performance plastics in the electronics and electrical industry.



Polyamides and polybutylene terephthalates, reinforced with a glass fiber content of up to 60 percent, are ideal for applications in lightweight construction, which can be attributed to their strength and stiffness. They form a lightweight and economical alternative to sheet molding compounds (SMC) and other reinforced thermosets, as well as to metals like steel, aluminum and die cast zinc. LANXESS Performance Materials, therefore, has been regularly adding new variations to its already wide range of injection molding materials in this segment.

At PLASTINDIA 2023, LANXESS is exhibiting lightweight and sustainable solutions for automobiles such as front-end module structure, air intake hose, engine cover, brake pedal, spare wheel recess, oil module and other parts frequently used by automobile manufacturers. The company is one of the largest suppliers of high performance materials in the field of engineering plastics (Durethan®, Pocan®) both in India and globally. A breakthrough this year, is the application of these materials in both injection molded and blow molded designs in different parts of two wheelers, for example – blow molded single layer polyamide fuel tank. This is the first-of-its-kind application, in which specifically developed Durethan® BC550Z is being used to manufacture the fuel tank of two wheelers matching the stringent norms laid down by Environ-



mental Protection Agency, USA.

“India is emerging as one of the world’s fastest growing passenger car markets and second largest two-wheeler market in the world. This makes us optimistic about the prospects of our high performance plastics in India and a large platform like PLASTINDIA will only validate the potential. Various new applications are being continuously tested and tried by all large auto manufacturers and this year, the two wheeler industry holds promise too. The compounding facility for Durethan® and Pocan® in Jhagadia, Gujarat is able to address the needs of not just the Indian market but also customers overseas”, said Milan Vignjevic, Director – Sales and Marketing, LANXESS Performance Materials – APAC region.

“Our product portfolio is very comprehensive and robust, including not only a wide range of injection molding engineering plastics, but also blow moldable polyamide materials and extrusion grades, namely, Durethan® and Pocan®, which offer immense design flexibility and weight reduction to automobiles. We have achieved another product innovation in the production of continuous fiber-reinforced thermoplastic composites (TEPEX®). LANXESS subsidiary Bond-Laminates, which manufactures these composites, is now able to continuously series-produce large semi-finished composite products in which the continuous fiber layers can be oriented at almost any conceivable angle, thus allowing customization according to the application needs. These products, together with our excellent technical support can offer next-generation solutions to many of our customers’ design

and performance challenges”, added Thomas Babl, Head of the Regional Technical Marketing & Engineering Services, LANXESS Performance Materials – APAC region.

Commenting on the Indian market, Pankaj Khare, Business Head - LANXESS Performance Materials India Private Limited said, “With the support of the government, electric vehicles have started penetrating in the Indian market. LANXESS Performance Materials is perfectly poised to cater to this growing market through its broad portfolio of PA6, PA66 & PBT e-mobility application solutions. We encourage our customers to connect with us for their requirements of high performance plastics (including FR compounds) for battery systems and electric power train innovations.”

The global compounding network of LANXESS Performance Materials guarantees market and customer proximity. It has a compounding facility at its site in Jhagadia, Gujarat with a capacity of 20,000 metric tonnes. This facility manufactures polyamide and polyester composites reinforced with glass fibers and other fillers, namely products from the Durethan® and Pocan® product range, which in turn, offer benefits for a variety of applications in the automobile, electrical and electronics industries. Interestingly, this facility also has capability to develop and manufacture colored compounds, which helps meet the newer customer requirements in automobile as well as electronics and electrical industries.

The site in Jhagadia is a key manufacturing base for LANXESS Performance Materials globally and has been built to world class standards. The production facilities as well as the utility services at the site ensure safe and environmentally responsible operations.

#### About LANXESS

LANXESS is a leading specialty chemicals company with sales of EUR 6.1 billion in 2021. The company currently has about 13,200 employees in 33 countries. The core business of LANXESS is the development, manufacturing and marketing of chemical intermediates, additives and consumer protection products. LANXESS is listed in the leading sustainability indices Dow Jones Sustainability Index (DJSI World and Europe) and FTSE4Good.

The further information, please contact:

Website: [www.lanxess.in](http://www.lanxess.in)

Subscribe to  
**Industrial Products Source**  
at ₹550/- for 2-year.

## EcoProFleet Ensures a Digitally Optimized Material Flow

**From compact cars to pick-up trucks, the EcoProFleet driverless transport system developed by Dürr specifically for paint shops transports bodies with great flexibility. The Automated Guided Vehicle (AGV) comes into its own in combination with the new DXQ software products from Dürr's Digital Factory. Together, hardware and software enable variable production layouts, optimally controlled material flow and maximum efficiency and scalability in the industrial painting process.**

AGVs are key to a smooth transition between work decks and temporary factory storage, covering most of the painting process spectrum. EcoProFleet is designed for this variety. The AGV can pick up any model, from compact cars to SUVs and pick-up trucks to unique shapes like truck cabs, place them down in work decks, or keep them ready during the painting process.

In the paint shops of the future, where modular work boxes replace the old lines with their rigid cycle times, AGVs are on the move up to 24 hours at a time, in the case of the EcoProFleet. It is the only driverless transport system on the market now that can operate around the clock since it does not need to charge its energy stores overnight like other models. Instead, EcoProFleet connects briefly to charging points along its routes. These charging points are where the AGV would be stationary anyway, for example, when transferring a body to a work deck. The short interval is enough to charge the capacitors so that the AGV has enough energy after placing down the body to return immediately to the production area and start the next job.

### Flexible route changes

DXQlogistics.control is Dürr's tailored software solution for the driverless transport system's control logic. It controls the material flow digitally according to work deck utilization, equipment and availability.

The software can decide autonomously about the next job step and work deck based on the body type and defined process steps. To optimize logistics, it can also take in destinations outside the route chart, such as outward transfer stations or temporary storage locations. This means it can always respond flexibly, for example, if a malfunction occurs at a work deck or rework to a body surface necessitates changing the original route.

Ultimately, the combination of the EcoProFleet driverless transport system and the DXQlogistics.control software solution results in the optimal utilization of all work decks. Workers no longer need to wait for the next body

since the software plans all the tasks ahead and even factors in transport time. Unproductive downtimes and cycle time losses thus become obsolete, replaced by production efficiency. Since Dürr's hardware and DXQ software are perfectly coordinated and individually combinable thanks to their modular design, they will play an instrumental role in making the paint shops of the future much more flexible and scalable than was previously possible.

The Dürr Group has had a direct representation in India since 1997, and Schenck RoTec has since 1986. The Dürr Group currently employs around 680 staff there, offering the entire portfolio including sales and service: Dürr India, based in Chennai, offers painting, application, final assembly and energy efficiency technology products as well as air pollution control, noise abatement systems and battery coating lines. Since April 2015, Dürr India has also been offering on-the-job as well as classroom training in paint and application systems to customers at its training center. Schenck RoTec India, in Noida, produces balancing technology as well as testing and filling technology. The HOMAG Group produces machinery and equipment for the woodworking industry. It has a presence in Bangalore, where it operates a production site and sales and service company HOMAG India.



The combination of EcoProFleet and DXQlogistics.control ensures optimal utilization of all work decks

The Dürr Group is one of the world's leading mechanical and plant engineering firms with extensive expertise in automation and digitalization/Industry 4.0. Its products, systems and services enable highly efficient and resource-saving manufacturing processes in different industries. The Dürr Group supplies sectors like the automotive industry, mechanical engineering, chemical, pharmaceutical, medical technology and woodworking industries.



It generated sales of •3.54 bil-lion in 2021. The company has almost 18,400 employees and 120 business locations in 33 coun-tries. The Dürr Group operates in the market with the brands Dürr, Schenck and HOMAG and with five divisions:

- **Paint and Final Assembly Systems:** paint shops as well as final assembly, testing and filling technology for the automotive industry, assembly and test systems for medical de-vices
- **Application Technology:** robot technologies for the automated application of paint, sealants and adhesives
- **Clean Technology Systems:** air pollution control, noise

abatement systems and coat-ing systems for battery elec-trodes

- **Measuring and Process Systems:** balancing equipment and diagnostic technology
- **Woodworking Machinery and Systems:** machinery and equipment for the woodwork-ing industry

For further information please contact:

**Dürr India Private Limited**  
**Kabilan Veeraiyan**  
**Management Systems & Marketing**  
**Tel: +91 44 43 93 1-606 1 E-mail: kabilan@durrindia.com**

## Monitoring and Documenting Ultrasonic Frequency and Power In-Line on a Batch-by-Batch Basis

In high-purity industries, companies are increasingly faced with the challenge of recording and documenting all cleaning process parameters for each batch of parts. Until now, in-line measuring of ultrasonic frequency and power in fully automated immersion cleaning systems has been a problem. Thanks to the development of the APM (Acoustic Performance Measurement) solution, Ecoclean has now solved this dilemma.

Precision cleaning in fully-automated, ultrasonic multi-

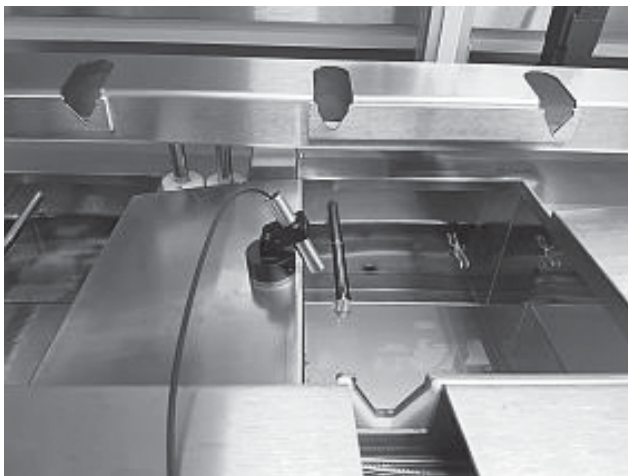

The APM reproducibly monitors ultrasonics parameters in-line for each batch using special microphones placed in a fixed position at the edge of the tank, which record the frequency and power. Analysis, evaluation and storage of the collected data are carried out by the innovative measuring system's software

bath immersion systems is state of the art in high-purity industries such as the medical device sector, precision optics and the semiconductor supply industry, as well as when it comes to analysis, laser and vacuum technologies. Companies not only have to consistently meet extremely high cleanliness requirements, but they also have to record and document compliance with all validated process parameters for each batch of parts. While existing in-line measurement technology makes it possible to monitor parameters such as temperature, conductivity and pH value of the baths as well as the dwell time of the parts in the baths in an easy and reproducible manner, up to now there has been no way to automatically monitor ultrasonic frequency and power in-line. The current practice is to use test foils, which do not allow deviations to be detected with sufficient accuracy, or hydrophones. With these methods, ultrasonic frequency and power are measured manually. Since the measuring device is moved during the monitoring step, measurement results are not reproducible. In addition, the sensor must be immersed in the various baths, which can lead to contamination.

### Reproducible, in-line batch monitoring with automatic analysis

Ecoclean GmbH's newly developed Acoustic Performance Measurement (APM) system, on the other hand, is capable of monitoring the parameters of ultrasonic frequency and power in-line at each processing station and for each batch. Special directional microphones are used for this, which are placed in a fixed position at the edge of each tank, and directed towards the centre of the bath surface.

# Company News



In addition to batch-by-batch monitoring, the APM system can also be used for monitoring at defined time intervals, such as once a shift or once a day. For this, the microphone is fixed-mounted to the automatic transport system, meaning that these measurements are also performed in a reproducible manner without contact with the medium

Thus, measurements are carried out without any movement or contact, ensuring reproducible results and enabling them to be precisely assigned to the batch concerned. Analysis, evaluation and storage of the data are carried out by the software of the innovative measuring system.

Under identical conditions, the microphone records the sounds emitted by the cleaning medium under identical conditions for each batch. The measured ultrasonic frequency and power values are continuously transmitted to the system's software, where they are evaluated by algorithms and compared with previously-defined and stored setpoint values of the part-specific cleaning program. Should there be any deviations, the system issues a warning or error message. To rule out the possibility of sounds from surrounding tanks falsifying the measure-

ment results, the software detects and masks out any interfering signals.

All data and evaluations recorded during in-line monitoring by the APM are automatically transferred to the cleaning machine's batch logging system, which comes as standard. This makes it easy to ensure and prove that the ultrasonically induced cavitation determined during validation of the cleaning process has been adhered to in production for each batch.

### **Alternatively: measurements at defined intervals**

If ultrasonic parameters do not need to be recorded for each batch, the APM can also be used to monitor parameters at defined time intervals, such as once a shift, once a day or once a week. For this measurement strategy, a microphone is fixed-mounted to the automatic transport system (ATS), so that here, too, measurements are made without contact with the medium and their reproducibility is guaranteed. For this check, the ATS advances to the respective tank where it measures both the frequency and the sound power. When the software analyzes and evaluates the data, the values measured are compared with set parameters defined during validation of the cleaning process for the treatment station. The measurement results are archived automatically in the machine's PLC, meaning that proof can also be supplied over a longer period of time. Compared to previous practice, even this application option of the new APM system offers far more reliable results and thus significantly higher process reliability .

Ecoclean's innovative APM won second place at the FiT2clean Awards, which were presented for the first time by Fachverband industrielle Teilereinigung e.V. (FiT) in 2022.

Contact:

[www.ecoclean-group.net](http://www.ecoclean-group.net)

## Industrial Products Source

April 2023

Pumps & Valves, Pneumatics &  
Hydraulics, Chemical & Petrochemicals  
Process Plant & Machinery

## IIT-Madras Research Park Signs Thin Film R&D MoU with First Solar

IIT Madras Research Park (IITMRP), India's first university-based research park, today announced that it has signed a Memorandum of Understanding with First Solar, Inc. (Nasdaq: FSLR), the largest American photovoltaic (PV) solar manufacturer (First Solar).

The two organizations intend to cooperate on a range of research and development (R&D) activities including the localization of supply chains in India of thin film and other next-generation PV technologies, high-volume manufacturing, testing of PV modules, and high-value recycling.

Prof. Ashok Jhunjhunwala, President – IIT Madras Research Park, IITM Incubation Cell & RTBI, said, "First Solar is the world leader in thin film solar and its knowledge and track record in both R&D and high volume manufacturing represents a tremendous opportunity for India, which is working to secure its clean energy supply chains. First Solar has demonstrated the potential of thin film to counter China's dominance of crystalline silicon with high performance solar panels that are competitive, sustainable, and responsibly produced. We are pleased to collaborate with the company to broaden our understanding of its technology, while sharing our expertise in renewables."

Unique among the world's ten largest solar manufacturers for being the only US-headquartered company, for not using a crystalline silicon (c-Si) semiconductor, and for not manufacturing in China, First Solar produces its thin film PV modules using a fully integrated, continuous process under one roof and does not rely on Chinese c-Si supply chains. The company's eco-efficient module technology, which uses its proprietary Cadmium Telluride



(CadTel) semiconductor, has the lowest carbon and water footprints of any PV module available today.

Kuntal Kumar Verma, Chief Manufacturing Officer, First Solar, on the MoU said, "First Solar has a long history of investments in R&D and partnerships with leading academic institutions around the world and we're thrilled to initiate what we anticipate will be a robust partnership with the IIT Madras Research Park," said Kuntal Kumar Verma, chief manufacturing officer, First Solar. "The MoU covers a number of areas that directly support India's decarbonization, energy independence, and sustainability goals and we would be pleased to share our experience, while also benefitting from the institution's expertise in areas such as field testing."

In 2021, First Solar announced that it would invest in a new full vertically integrated thin film solar manufacturing facility in Tamil Nadu with an annual capacity of 3.3 gigawatts (GW)DC. The facility, located in Pillaipakkam, Tamil Nadu, is expected to be commissioned in the second half of 2023.

### About IIT Madras Research Park

IIT Madras Research Park is India's first University-based Research Park and a Section 8 Not-for-Profit Company home to 75+ R&D companies, 240+ Startups and 9 Centre of Excellence. Envisioned to "Bringing unlike minds together", the Research Park primarily focuses on pioneering Industry-Academia interaction leading to commercialization of scalable and unique technology-based solutions, several of which have found wide market reach. The Research Park holds high eminence for epitomizing an innovation paradigm ecosystem across geographical



# Company News

boundaries, driving the roadmap towards achieving mammoth technological goals for India through its flagship project- 10X.

For more information:

**IIT Madras Research Park visit: <https://respark.iitm.ac.in/>**

## About First Solar, Inc.

First Solar is a leading American solar technology company and global provider of responsibly produced eco-efficient solar modules advancing the fight against climate change. Developed at R&D labs in California and Ohio, the company's advanced thin film photovoltaic (PV) modules represent the next generation of solar technolo-

gies, providing a competitive, high-performance, lower-carbon alternative to conventional crystalline silicon PV panels. From raw material sourcing and manufacturing through end-of-life module recycling, First Solar's approach to technology embodies sustainability and a responsibility towards people and the planet. For more information, please visit [www.firstsolar.com](http://www.firstsolar.com).

For further information, please contact:

**IIT Madras Research Park**

**Ravi / Saloni**

**Mob: 93828 87608, 98404 12140**

**E-mail: [ravishankar.kandarpa@mslgroup.com](mailto:ravishankar.kandarpa@mslgroup.com) / [saloni.bisani@mslgroup.com](mailto:saloni.bisani@mslgroup.com)**

## Borouge Accelerates Sustainability and Circularity in India with Innovative Polyolefin Solutions

- Borouge's design solutions incorporate recycled polyolefins to drive towards a circular economy
- Its sustainable and differentiated solutions for India's Infrastructure sector aim to better serve local communities
- 2023 marks 25 years of Borouge's continual commitment to value chain partners and customers

Borouge Plc (ADX symbol: BOROUGE / ISIN: AEE01072B225), a leading petrochemical company that provides innovative and differentiated polyolefin solutions, is advancing its sustainability and circularity ambitions in India with its value-creating products.

To further accelerate the transition to a circular economy, Borouge is showcasing groundbreaking innovations and solutions from its portfolio including Agriculture, Advanced Packaging, Circular Economy, Energy, Healthcare, Infrastructure and Mobility at PLASTINDIA 2023 from 1 to 5 February 2023 in New Delhi.

Rainer Hoefling, Chief Executive Officer, Borouge Pte Ltd said, "2023 marks a significant milestone for Borouge as we celebrate the 25<sup>th</sup> anniversary of service to our cus-

tomers including our Indian subcontinent partners. India has always played a critical role in our business expansion and we are heartened by the collaboration and partnerships that we have formed in the market. We see a perfect synergy between Borouge's growth ambitions in India and bringing our innovation and technological expertise to our partners in the market. We are committed to supporting the fast-growing industries in India by developing creative solutions that bring value to partners and customers."

PLASTINDIA 2023 marks the 11<sup>th</sup> edition of Asia's largest polymers exhibition. Borouge has been a key participant of the tri-annual trade show while contributing to the local communities via agriculture, water and gas infrastructure projects of national significance including the recent completion of 900 greenhouses in Jaipur, Rajasthan and the Urja Ganga Gas Pipeline Project.



Borouge's booth at PLASTINDIA 2023

"Borouge's participation in PLASTINDIA 2023 allows us to showcase our latest products and gives us the opportunity to reconnect with our customers in person to ensure that we are helping them respond to the dynamic market needs. The polyolefin market in India has expanded rapidly over the past two

decades and we are proud that our differentiated solutions not only contributed to industry developments in India, they have had positive impact on society as well. This is why we are confident and well-positioned in supporting our Indian customers while advancing our efforts in innovation, circularity and sustainability for a better tomorrow,” added Eddie Wang, Senior Vice President, Asia South, Borouge Pte Ltd.

## Highlights of Borouge’s products and solutions

With the company’s expansion of strategic partnerships with recycling companies recently, Borouge has also introduced design solutions that incorporate recycled polyolefins to drive the transformation towards a zero waste economy. Highlights include courier bag, collation shrink film, non-food bottle and cap application, all of which contain a combination of post-consumer recycled polyolefins and Borouge’s premium Anteo™ and Borstar® polyethylene grades. Other circular economy solutions include full PE mono-material pouches and packaging developed in collaboration with value chain partners.

Anteo™ FK1826 is a bimodal terpolymer linear low-density polyethylene produced using the proprietary Borstar® technology for high performance flexible packaging requirements. With its superior mechanical and sealing performance, Anteo™ promotes high throughput and cost-efficient processing in blown film production, offering further downgauging potential and cost competitiveness when used together with the Borstar® family.

RH668MO is a polypropylene random copolymer, based on proprietary Borstar® Nucleation Technology (BNT) that combines excellent clarity and aesthetics with superior productivity, designed for use in premium houseware and food containers. Its combination of high flow and BNT allows for cycle time reduction and energy savings, providing tangible cost and sustainability benefits.

Also featured is the Borstar® FB1200, a bimodal polyethylene designed for agriculture films which come with a unique matt surface, excellent mechanical strength and toughness, and superior melt strength and higher bubble stability. It complements Borouge’s suite of agriculture solutions for greenhouses, mulch films, aqua pond liners, and drip irrigation, enhancing farming efficiencies with precision farming with benefits including crop yield

improvement, water savings and resource conservation.

Borouge is also displaying its differentiated solutions for the Infrastructure sector, featuring its latest product portfolio that promotes durability and sustainability with the goal of better serving communities in India and globally.

One of Borouge’s key exhibits at PLASTINDIA 2023 is BorSafe™ HE3490-ELS-H, its latest PE100 solution for thick-walled and large diameter pipes in industrial applications. A recent addition to Borouge’s high-density polyethylene (HDPE) pressure pipe portfolio, it has superior low sag properties that enable a more uniformly distributed wall thickness compared to conventional PE100 materials, delivering tangible material savings for pipe producers.

Borouge has also recently introduced Borstar® HE3477-RT, a new innovative polyethylene of raised temperature resistance (PE-RT) Type II bi-modal material, designed for heating and industrial pipes that can achieve more than 50 years of service life at elevated temperatures. Its superior processability allows for easier production of heating and industrial pipes with larger diameters than most PE-RT Type II currently available. It is also an excellent material that can address the growing demand for replacing conventional metallic materials in district heating and industrial applications.

Borouge is bringing its polymer solutions to life with live machine demonstrations at PLASTINDIA 2023, which will be open to all event participants. Borouge’s booth at PLASTINDIA 2023 is located at 2H, GF-D1.

## About Borouge Plc

Borouge Plc, listed on the Abu Dhabi Securities Exchange (ADX symbol “BOROUGE” / ISIN “AEE01072B225”), is a leading petrochemical company that provides innovative and differentiated polyolefin solutions for the energy, infrastructure, mobility, advanced packaging, healthcare and agriculture industries. ADNOC owns a majority 54% stake, and Borealis holds a 36% stake in Borouge. To find out more, visit: [www.borouge.com](http://www.borouge.com).

For further information, please contact:

**Rehab Omar Ateeq**  
Vice President, Global Communications  
E-mail: [media@borouge.com](mailto:media@borouge.com)

**Subscribe to:**  
**Industrial Products Source**  
**at ₹300/- for 1 year; ₹550/- for 2 year.**

# Products INDEX

<b>A</b>		<b>C</b>	
AC Capacitors		c-i Cable Drag Chains	12
AC Fail Annunciator	26	Cables & Wires	7
Accelerating Design with Solutions	8	Capacitance Type Level Transmitters	17
Additive Manufacturing Services	19	Capacitors	c-i
Adhesive Sealants	23	Cartonator Pockets	4
Aerial Bunch Cable ABC upto 11 kV	7	CCT / Cat-5 / LAN Cables	7
Aerial Bunched Cables	7	Centreless Grinding Machine	6
Air Velocity Kit	17	Centrifugal Finishing Machine	11
Aircrafts Components	14	Ceramic Bearings	13
All Kinds of Other Special Cables	7	Ceramic Infrared Heater	3
Alloy Steels	c-ii	Clamps for Photo Cells	4
ALPHA Horizontal Bed Heavy Duty		CNC Machines – 5 Axis	c-iv
Precision CNC Lathe	13	CNC Machines – Turning - Milling –	
Anti Crane Collision Sensor	15	Applications	c-iv
Anti-Collision Device	c-i	CNC Router Machine	42
Anti-spatter Polyurethane Tubes	36	CNC-Lathe Machine – Heavy Duty	c-iv
APFC Control Panels	c-i	Co-axial / Instrumentation /	
Arc Welding Machine	22 & 35	Computer Cables	7
Armchair	c-i	Coiled & Disc Springs	c-ii
Automated Reference Method Sampler	5	Cold Work Tool Steels	c-ii
Automatic Biscuit Making Plant	24	Compact Geared Motor	c-iii
Autonomous Measuring Cells with		Computer-Controlled Pipecutter, 4-Axis	31
Integrated Handling Robot	29	Concrete Cutter Machine	21
Axial Flow Fans	41	Conductivity Level Switches	17
<b>B</b>		Cone Crusher	5
Bagging System – Manual	20	Cone Hydro Extractor	30
Ball Screws	11	Constant Wattage Heating Cables	3
Barometer	17	Control Cables	36
Beam Welding Cutting Machine	20	Conveyor Belts	19
Belt Conveyors	5	Conveyors & Components	4
Bipod	4	Counters	13 & 15
Blasting Machine	25	Crane Automization	c-i
Blasting System for Roll Etching	38	Crane Scale	c-i
Brackets & Guides	4	Customized Gears	c-iii
Brute Force Screen	5	Cut Gaskets, Non Metallic	19
Built-in Cylinder Power Collet Chucks	10	Cutter Pillar	19
By-Pass Rotameter	17	Cyanoacrylates Adhesive	28

Cylindrical Grinding Machine	10	<b>G</b>	
Cylindrical Grinding Machine	6	Gas Filled Power Capacitors	c-i
<b>D</b>		Gear Assemblies	c-iii
Defence & Aerospace Gears	9	Gear Boxes	c-iii
Diamond Grinding Wheels	30	Gear Design Software	c-i
Die Designs	c-i	Gear Drives	c-iii
Die Steels	c-ii	Geared Motors	c-iii
Digital Humidity Indicators / Controllers	13	GI Pipes	21
Digital Multimeter, Model - KM 60-T	12	Glass Tube/Acrylic Rotameters	17
Digital Pressure Gauges	17	Gravity Limit Switch	c-i
Digital Pressure Switches	17	Gravure Printing Machine	23
Digital Pulse Mig Welding Machine	36	Grid Tie Solar Inverter	21
Digital Time Switches Crono® & Plus	12	Grinding Machines	6
Drive Solutions	c-iii	<b>H</b>	
Driver Gloves	16	Heavy Duty Bucket Elevator	5
Drop Point of Grease Apparatus (SICBDPG-01)	16	Helibevel Geared Motor	c-iii
<b>E</b>		Helical Inline Geared Motor	c-iii
Electro Hydraulic Thrustor Brake	c-i	Heliworm Geared Motor	c-iii
Electro Hydraulic Thrustor	c-i	High Engineering Plastic Shaft	4
Electromagnetic Flowmeter	17	High Frequency Screen	5
Electronic Safety Guards	15	High Precision Gears	9
Endless Belts	19	High Quality Pneumatic Printing Machines	34
EPCOS Capacitors	c-i	High Tension Transformer	33
Extruded Rubber Cord	24	High Voltage Transformers	18
<b>F</b>		Highly Efficient IE4 Smooth Surface Motors	17
Fiber Laser Marking Machine	29	Hook-up Wires	7
Fire Retardant Coating	32	Hot Work Tool Steels	c-ii
Firefighting Panel	31	House Wiring / Multicore Cables	7
Flat Tangential Belts	19	HT Switchgear Panel	40
Flexible / Industrial Cables	7	Humidity / Temperature Logger	13
Flexible Couplings	11	Hydraulic Fittings	40
Flexible Couplings/Precision Locknuts/ Rolled Ball Screws	14	Hydraulic Machine Oil Cooler	32
Flexible Geared Coupling	c-i	Hydraulic Pumps	9
Flow Meters	13	<b>I</b>	
Flow Switches	17	Impact Hammer Crusher	5
Forging Components c-ii		Impact Sockets	c-ii
Forging/Casting Simulation	c-i	Indication System to Monitor Conveyor Safety Switch Status	15
FR / FRLS / PVC Cables (HT & LT Cables)	7	Inductive Proximity Switches	15
		Industrial Gear Boxes	9

Industrial Infrastructure Lighting	26	Mig Mag Welding Machine	27
Industrial Milling Machines	38	Mini Infra Red Sensors	15
Infrared Sensors	15	Modular Dry Type Power Capacitors	c-i
Insulated Conductor Bar	c-i	Modular Supports	4
Internal (Bore) Grinding Machine	6	Mosfet Base Welding Machine	32
<b>K</b>		Moulded Plugs	7
Kusam-Meco True RMS Digital Clampmeter		Multi Wire Cable Trolley	c-i
Model KM 2719	6	<b>N</b>	
<b>L</b>		Nickel Flanges	18
Lab Furnaces	3	Nylon Sandwich Belts	19
LAN Cables	7	<b>O</b>	
Large Display Counters	15	Oil Filled Power Capacitors	c-i
Level Adjusting Caster Wheels	14	<b>P</b>	
Lever Limit Switch	c-i	PAC/DC Welding Machine	39
Light Duty Cross Flow Fan – Centrifugal Blowers	28	Panel Accessories	3
Line Interactive UPS	32	Parameter Measurement (3-Phase) -	
Liquid Column Manometers	17	Model Nvis 7070	21
Liquid Level Indicators	17	Perion Ropes and Belt	19
Liquid Level Switches (Float Operated)	17	Perlon Ropes	19
Liquid Level Transmitter	17	Petrol Power Backup Generator	41
Lithium – Ion Battery 152P	19	Pharmaceutical Dust Collector	26
Loadcell Indicator	3	Phase Cap Capacitors	c-i
Long Pipeline Heating Cables	3	Photoelectric Sensors	15
Long Throat Depth Spot Welding Machine	34	PID Controller	3
Loose Gears	c-iii	Pin Type Load Cell	c-i
Low Profile Ratchet Type THL Series	10	Pipe Conveyors	5
<b>M</b>		Pipe Sealant	41
M.I.Power Cables	3	Piping Thread Sealant	39
M.I.Thermocouple Cables	3	Planetary Geared Motor	c-iii
Machine Tools	9	Plastic Mould Steels	c-ii
Magnetic Crack Detectors, Maxiflux		Pneumatic Actuated Butterfly Valve	17
Stationary Type	33	Pneumatic Denseveyor	24
Master Controller	c-i	Pneumatic Electric Cylinder	22
Material Handling Equipments	c-i	Pneumatic Grippers	18
Measuring Instruments	17	Pneumatic Positioners	28
Metal Forming Simulation Software	c-i	Pneumatic Welding Guns	25
Metal Tube Rotameter with Transmitter /		Polifan Flap Discs Z SG	25
Flow Indicator Totalizer	17	Poly Flex Belts	19
Microprocessor Based Engineering Unit		Poly V Belts	19
Model EU-08 RTP	28	Polyester Woven Lashings	10



Portable Non Maintained Lights	30	Scanners 3D (Highest Resolution)	c-i
Potentiometers	4	Seam Welding Machine	27
Power & Control Cables (Aluminium / Copper / Conductor / Armoured Unarmoured Cables)	7	Self-Limiting Heating Cable	3
Power Capacitors	c-i	Sensors	15
Power Factor Controller	c-i	Shaft Mounted Speed Reducer	c-iii
Power Tools	9	Short Stroke Conductive Plastic Potentiometer	4
Precision Locknuts	11	Short Wave Infrared Heater	3
Pressure Switches	17	Silicone Sealant	34
Pressure Transmitters	17	Single Toggle Jaw Crusher	5
Process Instruments	17	Slewing Bearings	15
Programmable Counter	15	Socket Screws, Countersunk	35
Pulley in all Pitch for Timing Belt	19	Solar Cables	7
Pulse Jet Bag Filter	5	Solar Hot Water System	42
Pushbutton Switches	3	Solar Lantern	36
PVC Insulated Industrial Wires & Cables	7	Sorting Automation Systems	23
<b>Q</b>		Special Vee Belt & Flat Belt Pulley	19
Quick Release Couplers – Pneumatic	22	Specialized Cables	6
<b>R</b>		Speed Reducer	34
Ratchets	9	Spiral Bevel Gears	9
Radio Remote Control	c-i	Spring Steels	c-ii
Relative Humidity & Temperature Transmitters	3	Sprockets	9
Relays & Relay Modules	11	Square & Round Bars	c-ii
Repairs and Servicing of Ball Screws	11	Square Cap Capacitors	c-i
Resistance Box	c-i	Stainless Steel Pipes	20
Resonance Screen	5	Stainless Steel Pulverizers	42
Robot Simulation and offline Programming	38	Starter Motor Shafts	9
Robotic Machine Tending	40	Steam Boilers, Vertical	26
Robotic Welding	8	Stretch Wrappers	39
Rolled Ball Screws	11	Superior Quality Cutter-Crushers	29
Rollers for Machine Movement	18	Surface Grinding Machine (Manual)	6
Rotary Air Lock Valves	16	Surface Plates with Bench Centre & Box Angle Plate	14
Rotary Conductive Plastic Servo Potentiometer	4	<b>T</b>	
Rotary Limit Switch	c-i	Tachometers	13
Rotary Limit Switch for Cranes	16	Taparia Carpenter Tools Jack Plane	15
<b>S</b>		Telecommunication Cables	7
Safeload Controller	c-i	Temperature Measuring Instruments & Allied Products	17
Safety Bump Cap to Protect at Work	42	Temperature Transmitters	3
Safety Guards	15	Terminal Connectors	3
Safety Light Curtains	15	Thermocouple Assemblies & Thermowells	3

Thermocouple Cables	3	<b>V</b>	
Three Core Flat Submersible Cables	7	Vacuum Manometer	17
Through Beam Sensors	15	Valves And Solenoid Valves Series EN	12
Thyristor Switch Module	c-i	Vertical Machine Center – Twin Spindle	c-iv
Timing Belts	19	Vertical Shaft Impactor	5
Tool & Alloy-Special Steels	c-ii	Vibrating Feeder	5
Tools – Collets	c-ii	Vibrating Grizzly Feeder	5
Transformers & Chokes, Inductors & Reactors	40	Vibratory Finishing Machine	8
Transmission Gears	9	<b>W</b>	
Tripod	4	Waste Oil Heater	22
Trouble Free Performance Hydraulic Cylinder	39	Wedge Space Saver Belts	19
TRS / TRS Braided / Welding Cables	7	Welding Rotators	33
Tube Bundle Heat Exchanger	23	Wire Rod	c-ii
Tube Filling Sealing Machine	30	Wire Rope Load Cell	c-i
Turrets	20	Wood & Coal Fired 1000 Kg/Hr Packaged	
Two Hand Safety Device for Rolling Key Presses	15	Steam Boiler	41
Two Wheeler Battery – GMc-CS-2.5LC	29	Worm & Worm Wheel	9
<b>U</b>		Worm Reduction Gearbox	33
Ultrasonic Brass Inserts	24	Wrapping Machine	25

## A D V E R T I S E R S ' I N D E X

<b>B</b>		<b>M</b>	
British Electricals	3	Masyc Projects Pvt Ltd	5
<b>C</b>		Moldex Corporation	4
Countronics	13	<b>P</b>	
Crane Control Equipments	c-i	Pankaj Potentiometers Pvt Ltd	4
<b>D</b>		Photon Controls (India) Pvt Ltd	15
Devco Industries	6	Power Build Pvt Ltd	c-iii
<b>E</b>		Pragati Transmission Private Limited	9
Empire Cable Industries Pvt Ltd	7	<b>S</b>	
<b>F</b>		Shree Trading Syndicate	c-i
Fitzer Instruments Company (India)	17	<b>T</b>	
<b>K</b>		TRP Kwedos Belt Drives	19
Kadkraft Systems Pvt Ltd	c-i	<b>V</b>	
<b>L</b>		V.V. Mujumdar & Associates	11
Lakshmi Machine Works Limited	c-iv	Ventura Alloy and Steels Private Limited	c-ii

# With a reliable partner, your journey becomes smooth.

Ensure a smooth journey with PBL's reliable range of products.



**Loose Gears**  
Customized  
Gears



**Series A**  
Compact  
Geared Motor



**Series J**  
Shaft Mounted  
Speed Reducer



**Series M**  
Helical Inline  
Geared Motor



**Series C**  
Heliworm  
Geared Motor



**Series F**  
Parallel Shaft  
Geared Motor



**Series K**  
Helibevel  
Geared Motor



**Series PL**  
Planetary  
Geared Motor

GEARED MOTORS | GEAR BOXES | CUSTOMIZED GEARS | DRIVE SOLUTIONS

- Robust design • Modular construction • User-friendly interface • Quick installation
- Economical operation • Easy maintenance



Phone: +91-2692-231070, 231120, +91-75675 67567 | Website: [www.powerbuild.in](http://www.powerbuild.in) | E-mail: [infopbl@powerbuild.in](mailto:infopbl@powerbuild.in) |  



J  
S  
E  
R  
I  
E  
S

THE NEXT  
GENERATION  
PARTNER  
FOR QUALITY



## VERTICAL MACHINING CENTER

### FEATURES

- Direct drive spindle speed up to 10,000 / 12,000 rpm
- Precision linear guideways on X, Y & Z axes
- Faster tool change time <2 sec
- Ergonomically designed for easy loading / unloading operations
- Wider column ensures heavy duty machining
- Improved chip & coolant management
- Compact design with larger working area

### Stroke (in mm)

x - axis 600 — 1050

y - axis 500 — 600

z - axis 500 — 600

### Spindle Power (in kW)

7.5 — 22



www.lmwnc.com

INDIA'S FINEST  
RANGE OF CNC MACHINES

FOLLOW US ON:



LMW CNC



**LAKSHMI MACHINE WORKS LIMITED**

MACHINE TOOL DIVISION