

Industrial Products Source

ISSN 0973-1857

A Magazine for Indian Industries

Vol 21

Issue 3

March 2024

₹ 30/-

A Product News Publication

Total no. of pages 60

Visit: www.ips.co.in
to view our e-magazine

Focus:

Cables, Wires, Connectors, Control Panels Transformers,
Switchgears & Welding Equipment

Products Index
Page 54



AN ISO 9001:2015
AND CE CERTIFIED COMPANY



Electro Hydraulic Thruster Brake Electro Hydraulic Thruster Resistance Box Rotary Limit Switch Gravity Limit Switch Lever Limit Switch

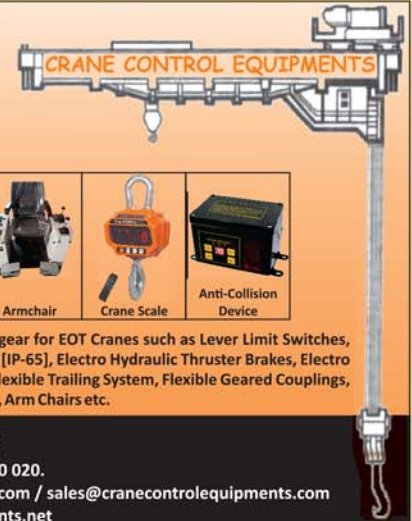

Master Controller Multi Wire Cable Trolley Flexible Geared Coupling Insulated Conductor Bar Radio Remote Control Crane Automization Wire Rope Load Cell Pin Type Load Cell Safeload Controller Armchair Crane Scale Anti-Collision Device

We are a national level company manufacturing & supplying for **THIRTY SIX YEARS** to OEMs & user/govt depts. Complete range of control gear for EOT Cranes such as Lever Limit Switches, Counter Weight Limit Switches, Rotary Geared Limit Switches, Differential Limit Switches, Master Controllers, Pendant Push Button Stations [IP-65], Electro Hydraulic Thruster Brakes, Electro Hydraulic Thrusters, Electro Magnetic Brakes, S S Punched Grid Resistance Boxes, Radio Remote Control, Shrouded Bus Bar System, C-Track Flexible Trailing System, Flexible Geared Couplings, Brake Drum Couplings, Cable Trolleys, Cables Reeling Drums, Gear Boxes, Crane Wheels, Digital Crane Scales, Load Cells, Anti-Collision Devices, Arm Chairs etc.

**DEALERS ENQUIRY
SOLICITED**

CRANE CONTROL EQUIPMENTS

Office & Works: B-249, Okhla Industrial Area, Phase - I, New Delhi - 110 020.

Tel: 011-4101 6403 to 405 • Mob: +91-98100 09466, 93100 09466 • E-mail: info@craneconrolequipments.com / sales@craneconrolequipments.com

Web: www.craneconrolequipments.com / www.craneconrolequipments.net

TACKLERS

Engineering Pvt. Ltd.



**50 Years of
EXPERIENCE**
backed by TRUST

Material Handling with
**SAFETY & QUALITY
AT CORE**



CRANE KITS

- Wire Rope Hoists
- New Generation Hoist
- Double Girder E.O.T. Crane
- Single Girder E.O.T. Crane
- Goliath Crane
- Jib Crane
- Transfer Trolley
- Chain Hoist
- Free standing Structures with Cranes
- Mechanical Tilters / Lifting Beams
- Wheels-Rollers for Sliding
- Crane Kits and Components
- Winch
- Rubber Tyre Gantry Crane
- Chain Pulley Block
- Portable Gantry Crane
- Heavy Fabrication with Machining
- Floor Handling Equipments

Head Office & Unit 2: Plot 5,6,7 Devraj Industrial Park, Pipilaj-Pirana Road, Pipilaj, Ahmedabad-382405.

Registered Office & Unit 1: Plot G13, Phase 4, G.I.D.C., Vatva, Ahmedabad-382445

For Sales: 93287 39901, 93770 39904 | T: 97270 01125, 40323330 - For AMC & Service: 82382 33878, 93770 39905



TACKLERS
Engineering Pvt. Ltd.

Sales: info@technoind.com
AMC & Services: amc@technoind.com
Website: www.tacklers.in

Formerly Known As:



our customize product range make us

No.1

IN SURFACE FINISHING SOLUTION



Spl. Shot Blasting M/c For Fold-away
Tray of Sheet Molding Compound



Spl. Shot Blasting M/c for Gear
Cutters Tools before PVD Coating



Spl. Blasting M/c for Cleaning of
Submersible Pump Casing



Airless 4W Tunnel Type Blasting
M/c for Sheet Blasting



PRESERVATION LINE
Inline Blasting, Painting & Baking System



BLAST ROOM & PAINT ROOM SYSTEM
Supplied For Rail Chassis Body



Airless 4W Tunnel Type Blasting
M/c for Sheet Blasting



PRESERVATION LINE
Inline Blasting, Painting & Baking System



BLAST ROOM & PAINT ROOM SYSTEM
Supplied For Rail Chassis Body



SPARE PARTS & ABRASIVES

**MEC SHOT BLASTING
EQUIPMENTS PVT. LTD.**

H.O. & Works: B-14, Parshvath Industrial Estate Yojna
Khasra No. 160, Mogra Kalan, Tehsil - Luni
JODHPUR - 342802 (Rajasthan) INDIA



0291-2740609 | E-mail: mail@mecshot.com | Website: www.mecshot.in



EMPIRE CABLES

Connecting Your Life



PRODUCT RANGE

- Power & Control Cables (Aluminium/Copper Conductor/Armoured Unarmoured Cables)
- FR / FRLS PVC Cables (HT & LT Cables)
- House Wiring / Multicore
- Flexible / Industrial Cables
- Hook up Wires
- 3 Core Flat Submersible Cables
- Telecommunication Cables
- Co-axial / Instrumentation / Computer Cables
- Aerial Bunched Cables
- TRS / TRS Braided / Welding Cables
- CCTV / Cat-5 / LAN Cables
- Solar Cables
- Moulded Plugs
- All Kinds of Other Special Cables



Mfg. by :

EMPIRE CABLE INDUSTRIES PVT. LTD.

115, Badli Industrial Area, Phase-2, New Delhi (India)

website : www.empirecables.net

Email : enquiry@empirecables.net

Toll Free No.: 1800-202-7972

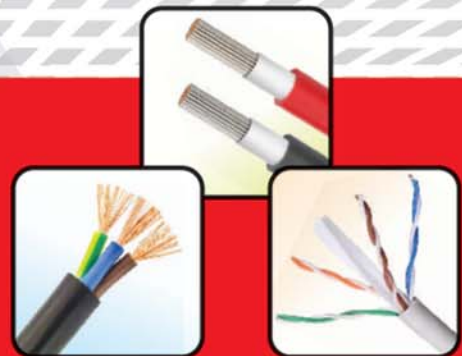



Manufacturers of wide range of Industrial fans

- ▶ Axial Fans ▶ External Rotor Motors ▶ Centrifugal Fans ▶ DC & EC Fans
- ▶ Single & Double Inlet Centrifugal Blowers ▶ Forward & Backward Curved Blower Fans

Industries Served



Axial Flow Fans
Size : Ø200mm - Ø630mm
Air Flow : 450M³/hr to 11785M³/hr



Inline Duct Fans
Inlet Size : Ø100mm - Ø400mm
Air Flow : 300M³/h to 4200M³/hr



Single Inlet Blower
Fan Size : Ø120mmx30mm to
Ø280mmx115mm
Air Flow : 140M³/hr to 2750M³/hr



Double Inlet Blower
Fan Size : Ø133mm x 120mm to
Ø240mm x 280mm
Air Flow : 400M³/hr to 4400M³/hr



Roof Extractor
Fan Size : Ø280mm - Ø 400mm
Air Flow : 500-4200 CMH



Axial Flow Fans Long body
Fan Size : Ø300mm - Ø800mm
Air Flow : 2600M³/hr to 16000M³/hr



Polypropylene Blowers
Fan Size : Ø200mm - Ø315mm
Air Flow : 500M³/hr to 4260M³/hr



Flame Proof / Non Flame Proof Extended Shaft Dual Inlet Blower
Size : Ø108mm - Ø250mm
Air Flow : 900M³/hr to 7000M³/hr
Also available single side type

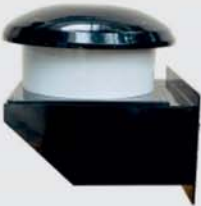

Wall Mounted
Fan Size : Ø190mm - 400mm
Air Flow : 500-4000 CMH



Fresh Air Fan with HEPA filter
Fan Size : Ø200mm - Ø400mm
Air Flow : 375M³/hr to 2050M³/hr
(UV-C LAMP AVAILABLE)



Regenerative Blower
Power Rating :
90 watts - 750 watts
Air Flow : 16M³/hr to 145M³/hr



Cabinet Fan
Fan Size : Ø250mm - Ø800mm
Air Flow: 690M³/hr to 17100M³/hr

EYYANI ELECTRIC MACHINES PVT. LTD.

An ISO 9001-2015 Company

Regd. Off. & Works : B-234, 5th Main, 2nd Stage, Peenya Indl. Estate, Bangalore - 560 058 Phone : 080 - 2836 4923 / 24
Mobile : + 91 8762801242, 94484 97090 e-mail : sales@eyyani.com, eyyanielectric@gmail.com / www.eyyani.com

Our Stockists : New Delhi : +91 99682 93271 / 98910 42099 Ernakulam : +91 94464 36315

Industrial Products Source

(A Product News Publication)

Vol. 21 No. 3 March 2024

Editor & Publisher: Mohanan N
Mobile: 098206 70855

Sub Editor: Ramachandran. T
✉: ipseditor@gmail.com

Marketing Manager: V Madanmohan
Mobile: 098208 38998

Layout Artist: Chandrakant G. Kadam

Single copy price: ₹30/-

Annual Subscription: ₹300/-

Regd Office

A/10 Jayshree Laxmi Puja CHS, Plot No: 78/82
Ramachandra Nagar, Dombivli (E), Thane 421 201

Editorial, Marketing & Advertising

104 Sudama Yash
Nr: Ramkrishna Hotel, Kelkar Cross Road, Ram Nagar,
Dombivli (E), Thane 421 201
✉: ipsmaginfo@gmail.com
ipsmag@yahoo.com

Representatives

Coimbatore: Rajeev Kumar, Mobile: 094431 29073

Industrial Products Source is a product news monthly publication, registered with the Registrar of Newspapers for India, under No: MAHENG/2004/12919.

Industrial Products Source reserves the right to use the information published herein in any manner whatsoever. The Editor/Publisher to the best of their ability have tried to check the accuracy of information published in this issue which is based on the material supplied by respective manufacturers/agents/advertising agencies.

Neither **Product News Publication** nor any of its employees will be morally or legally responsible for any errors or omission. No part of this publication may be reproduced in any form without the written permission of the publisher. All rights reserved.

Printed and Published by Mohanan N on behalf of **Product News Publication** and printed at Perfect Prints, 22/23 Jyothi Industrial Estate Noori Baba Darga Road, Near Makhmali Talao Thane 400 601, and published from A/10 Jayshree Laxmi Puja CHS, Plot No: 78/82 Ramachandra Nagar, Dombivli (E), Dist: Thane 421 201.

Editor: Mohanan N

CONVEYORS & COMPONENTS



A WIDE RANGE TO CHOOSE

- Slats in Delrin, S.S., M.S
- Multi Directional
- Universal Flex
- Stackable
- Min / Backline Force
- Nylon, MS, SS Sprockets
- Brackets + Guides
- Clamps for Photo Cells
- Cartonator Pockets
- Tripod & Bipod
- Modular Supports

 **moldex corporation**



A-9, New Empire Industrial Estate, Kondivita Road, J.B. Nagar
Andheri (E), Mumbai 400 059
Phone: 022 - 4015 5959 • Mob: 99200 52389
E-mail: info@moldex.in / krish@moldex.in
Website: www.moldex.in

 **Always moving..innovative products developments**

Rotary Conductive Plastic Servo Potentiometers

Model: RCP-35-A

Body Diameter - 35 mm,
Body Height - 23 mm,
Shaft Diameter - 6 mm,
Shaft Length - 15 mm,
Mechanical Angle of Rotation - 360 Degrees,
Electrical Angle of Rotation - 355 Degrees,
Resistance Values - 1K, 5K, 10K Ohms.



Model: RCP-50-A

Body Diameter - 50 mm,
Body Height - 24 mm,
Shaft Diameter - 6 mm,
Shaft Length - 15 mm,
Mechanical Angle of Rotation - 360 Degrees,
Electrical Angle of Rotation - 355 Degrees,
Resistance Values - 1K, 5K, 10K Ohms.



Manufacturers & Exporters: **Pankaj POTENTIOMETERS PVT. LTD.**
201-B, Udyog Mandir No.1, 7-C, Pitamber Lane, Mahim, Mumbai 400 016, India
Tel. : +91 22 3163 3520 • Mobile : +91 98690 50801
E-mail : pankaj.potentiometers@gmail.com • Website: www.pankaj.com

MADE IN INDIA
CE
ANAR

SRI BHOOMIDURGA MARKETING (P) LTD

#11, Old #27, Janakiram Colony, Arumbakkam, Chennai - 106.

ONE STOP SHOP FOR ALL ELECTRICAL UTILITIES

Ph: 044 4264 0550 / 0552 , Cell : 94444 44819 / 89397 12295



SUPREME POWER EQUIPMENT PRIVATE LIMITED

- Oil Cooled Distribution Transformers upto 2500KVA, 33KV
- Oil Cooled Power Transformers upto 50MVA, 110/132KV
- Windmill Transformers
- Solar Inverter Duty Transformers
- Rectifier & Furnace Duty Transformers



- HT / MV Switch Gears (11/22/33kV)
- Unitised Substation (USS)
- Ring Main Gear (RMG)
- VCB (Indoor & Outdoor)
- Msmart Series VCB



Proactive Monitoring

www.spowerz.com
info@spowerz.com

Energy Monitoring Solutions and Equipments (**POWERZ**),
Street Light Control Solutions (**SLitZ**),
Wireless Calling System (**CallBeeZ**),
Andon System (**i-Smart AndonZ**)



Quality First Service Next

www.sribhoomidurga.com



Channel Partner



Electrification Business to Sell Distribution System (DA, OA, RMU and services) Products & Spares

Rolling Contact Servo Controlled Automatic Voltage Controller (HT< Stabilizer) from 30KVA to 5000KVA



**Sri Bhoomidurga Marketing (P) Ltd
Control Transformer Manufacturing Division**



CT



Control Transformer



Stabilizer



www.sribhoomidurga.com



venu@sribhoomidurga.com, sales@sribhoomidurga.com

Quality First Service Next

www.sribhoomidurga.com



Head Mount Smart Temperature Transmitter

British Electricals offers Head Mount Smart Temperature Transmitter. General Features: Universal Input, support RTD: Pt100, Cu 50, Cu 100; Thermocouple: K, J, E, T, S, R, B, N, PT 1000 and are needs to be custom made; 2 Wires 4-20 mA output; Input configurable via PC software and Android smart phone; Built-in cold junction compensation; Can be installed in Form B connection box; High accuracy, 0.1% for RTD, 0.2% for TC; USB cable for configuration purpose can draw power from PC directly separate 24 V DC power source is no need; Surge Protection, reverse connection protection. General Specifications – BE-TT-101: Cold end junction compensate range: -40°C +80°C; Compensate accuracy: ±1°C; Output 4-20 mA; Load Resistance: $RL (Ue-12) / 0.021$; Over range alarm value: $I_H = 20.8 \text{ mA}$, $I_L = 20.8 \text{ mA}$; Input break output current value: 21 mA; Power Supply: 12-35 V DC; Accuracy (ambient 20 °C): 0.1% FS for RTD, 0.2% FS for TC; Temperature drift: 0.01% FS/ °C; Response Time: 1 ms to 90% of maximum output; Input/output impedance: Non-isolation; EMC Standard: IEC 61326-1; Working Temp.: -40°C+80°C.



Contact:

British Electricals
 237/8 Sonal Link Ind Estate Building
 2 Link Road, Malad (West), Mumbai 400 064
 ☎ 022 – 4062 0000 • E-mail: sales@britishelectricals.com

High-Quality and Economical Solutions

MFGRS: EOT Crane Components

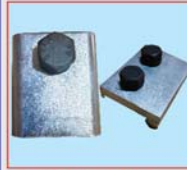

Rail Clamps



Thruster Brakes



Hydraulic Thruster Brake



Resistance Box



Crane Limit Switches



Cable Trolley

Vijayalaxmi Enterprises

17/603, Regency Estate, Kalyan-Shil Road
 Dombivali (East), Thane 421 203
 Mob: 79774 16311 / 90046 85089
 E-mail: info@vijayalaxmienterprises.in

Dealership Enquiries Solicited





INNOVATIVE SOLUTIONS, ENDURING RESULTS

High Temperature Heating (NiCr Series)

WIRES | STRIPS | RIBBONS | BARS



JLC Electromet Pvt. Ltd., E-153(A), Road No. 11-H, V.K.I.A.,
 Jaipur - 302013 | Call : +91-141-233 1215
 E. : contactus@jlc.co.in | www.jlcelectromet.com





join the best :
 15-19 April 2024
 Düsseldorf, Germany
 Please visit us at : Hall 12/C71

EXCLUSIVELY FOR
ELECTRICAL & ELECTRONICS INDUSTRY

If you are looking for Connectors
We have the best **Rtex Circular Connectors**

700 ◀ MORE THAN ▶ **500**

Happy Customers

Types of Connectors

Fast & timely delivery

Cycle - Mechanical Life

- ✓ Durability
- ✓ Heavy Duty
- ✓ High Reliability
- ✓ Extream Capacity
- ✓ JSS 50812 Standard



20% LOWER RATES

7, Rukhmini Chambers, Pune - Satara Road,
Near Sai Hospital, Katraj, Pune - 411046 (India)



✉ rtexrs16@yahoo.co.in

🌐 www.rtexconnectors.com

Tel: +9120-26959713 Cell: +919890608882

India's Largest Round Shell Connectors Manufacturing Company

**INDUSTRIAL SPRINGS
& SPRING WASHERS**



All types of springs for different uses available in
Spring Steel and in SS 304.

Spring Washers available in sizes from 2.5 mm. to 50 mm.

**Special combi-size washers are
also available in all sizes.**

- ▶ Material : Spring Steel (EN-42 B) and Stainless Steel SS-304
- ▶ Finish : Natural Black, Zinc Plated in trivalent passivation.
- ▶ Standard : IS:3063, IS:6735, BS:1802, DIN-7980, JIS, ASA

Khanwalkar Industries

Fac. & Off. : 36-C, Sector B, Sanwer Road Industrial Area,
INDORE 452 015 (M.P.)

Tel. : 0731 4046226, Cell. : 09993555087, 75665 05559

e-mail : kxanwalkar08@gmail.com

www.khanwalkarindustries.com

Signal & Instrumentation Cables

KEI Industries Limited offers Signal and Instrumentation Cables. Its Applicable Standards: BSEN 50288 Part-7, IEC-60092, PAS 5308. Voltage: Up to 1100 Volts; Products Range: Multicore/Multi-pair/Multitraid Signal Instrumentation Cables (Conductor Size: Up to 6 sq mm). Conductor: Tinned/Plain Copper as per BS EN 60228. Insulation:



XLPE/PE/HFFR/EPR/PVC. Screening Individual, Pair/Traid Screening or Overall Screening or Both): Aluminium Mylar Tape Screening, Copper Tape/Wire Screening, and Tinned Copper Braiding. Inner Sheath and Outer Sheath: PVC/PE/HFFR/PCP/CSP/FRLS PVC/FR PVC. Armor: Galvanized Steel Wire/Flat Strip Armor, Galvanized Steel Wire Braiding, Tape Armor (Galvanized Steel/Copper/Aluminium). The company's products range includes: EHV Cables up to 400 kV; HT Cables up to 33 kV – Dry Cured Process; LT Power Cables – Copper/Aluminium Conductor PVC, XLPE and EPR; LT Control Cables – Copper PVC, XLPE and EPR, Flexible and House wires (Single and Multicore); Elastomeric (Rubber) Cables; Railway Signaling Cables; Fire Survival, Zero Halogen Cables; Dry Filled Telephone Cables; Automotive Cables; Welding Cables; Submersible Cables/Winding Cables; Ship Wiring Cables; Mining Cable-Rubber as per IS 14494 and PVC; Cables for Offshore Installation; Cables for Defence; AB Cables; and Communication Cables.

Contact:

KEI Industries Limited

D-90, Okhla Industrial Area, Phase-1, New Delhi 110 020

☎ 011 – 2681 8840, 2681 8642

E-mail: info@kei-ind.com

Electrical Products

Sakthi Electrical Control, an ISO 9001:2015 certified Company manufactures and exports electrical products. The products are: Servo Voltage Stabilizers – Air Cooled – 1 kVA to 500 kVA, and Oil Cooled – 3 kVA to 3000 kVA; Isolation Transformers – from 1 kVA to 1000 kVA; Rectifiers – from 100 Amp to 500 Amp 5 V to 600 V DC; Battery Chargers – 12 V to 120 V (5 A – 60 A); VFD – 1 HP to 500 HP; Solar Pump Controller – 1 HP to 30 HP (3 Phase). Products range includes: Online UPS, Inverters, Phase Converters, Active Harmonic Filters, APFC Panels, Energy Savers, etc.



Contact:

Sakthi Electrical Control

47 Bharathi Street, Chinnavedampatti, Ganapathy PO

Coimbatore, Tamil Nadu 641 006

☎ 0422 – 495 0700 • Mob: 97860 77355

E-mail: info@sakthistabilizer.in

International Machine Tools & Industrial Trade Fair



Organised by



CODISSIA
Intec Technology Centre

INTEC 2024

06th to 10th June 2024

CODISSIA Trade Fair Complex, Coimbatore

CONCURRENT EVENTS



Exhibitors' Profile

Industrial Electrical & Electronics

General Engineering

Machinery for Process Industry

Metallurgical Plant & Equipments

Textile Machinery & Equipments

Fabrication Machinery & Equipments

IT Consulting & Service Providers

Machine Tools & Accessories

Hydraulics & Pneumatics

Material Handling Equipments & Machinery

Foundry Equipments

Pumps & Fittings

Precision Tools, Cutting Tools, Dies & Moulds, Welding

Instrumentations Automation

Factory Cleaning & Pollution Control Equipments

Industrial Consumables

Industrial Robotics & Automation

Sheet Metal Press & Laser Cutting

Power Tools & Testing and Measuring Equipments

3D Printing and Laser Marking

*Advanced
Manufacturing
with Low Cost
Machinery*

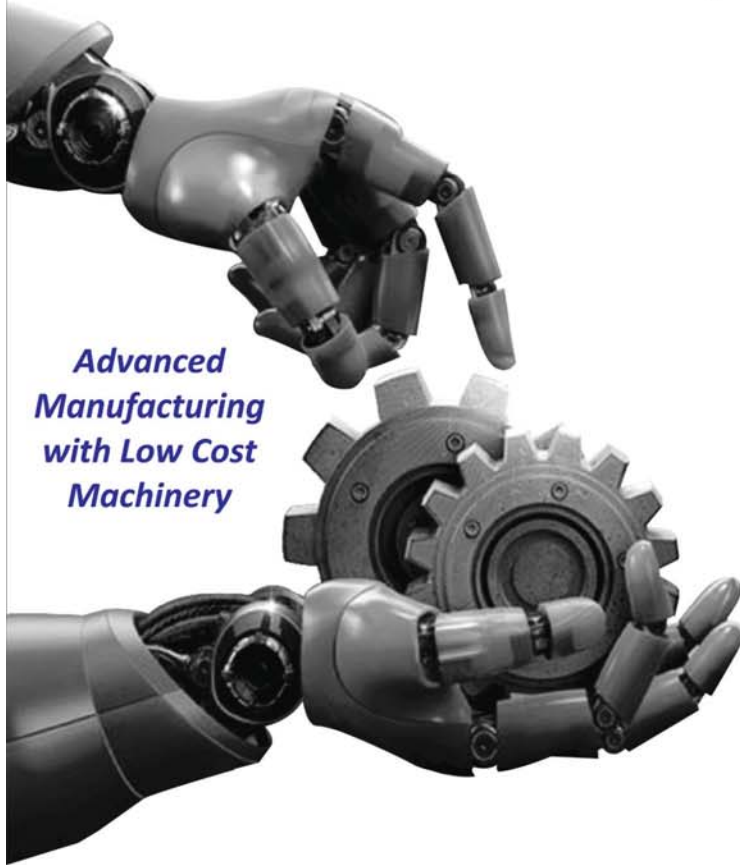

Diamond Category
Exhibitor

JANATICS
Pneumatic

Gold Category
Exhibitor



Conference Partner

TexasVentures
www.texasventures.us

E-magazine Partner

**INDUSTRY
4.0**
www.industry4.0.com

Halls
A, B, C, D & E
Fully Booked

Few Stalls
Available in Hall - G
Rush Your
Bookings

Ph : 99655 15182 / 88705 60333 / 85080 22000 / 75029 22000

E : intec@codissia.com W : www.intec.codissia.com

Medical Gas Pressure Monitor, Alarm and Data Logger 3-in-1 IoT System

A Touch-Based easily configurable and installable Medical Gas Pressure Monitor, Alarm and Data logger 3-in-1 IoT System is launched by Logic Research Labs - R&D. Med-



ical gas alarms are essential for Hospital gas line monitoring that is indigenously developed in-house using CE, FCC, and RoHS-certified components. The responsive capacitive 7-inch touch-based screen enables easy in-field configuration of up to 5 gases (Oxygen, Nitrous-oxide, MedAir 4, MedAir 7, and Carbon-di-oxide) and Vacuum. The display in Dial and Numeric format with Normal (Green), Low (Yellow), or High (Red), triggers precisely the alarm for abnormal ranges in (kg/cm², psi, bar, kPa) units. The data logger records pressure values continuously with real-time timestamp and stores them in internal memory along with temperature and humidity data in MSExcel file format that can be copied to an external USB for analysis. IoT Alarm enables remote monitoring and escalation features to notify service personnel or display them on a centralized dashboard.

Contact:

Logic Research Labs

7/268 Jayalakshmi Nagar, Pillaiyampettai

Ammachatram, PO: Kumbakonam

Tamil Nadu 612 103

Mob: 99523 39966 • E-mail: contact@logicresearchlabs.com

Slip Rings

Reckers Automation offers a range of Slip Rings such as Capsule Slip Ring, Through Bore Slip Ring, Miniature Slip Ring, Pin Slip Ring, Ethernet Slip Ring, Wind Turbine Slip Ring, HD SDI Slip Ring, Electrical Slip Ring, Customized Slip Ring, etc. Applications: Packaging Machine, Beverage Filling machine, Knitting Machine; Medical Instruments; CCTV and Video Surveillance System; Lithium Battery Equipments; Wind Mill, etc. Reckers also supplies Permanent Magnet Synchronous Motors, BLDC/Stepper Motors, etc.

Contact:

Reckers Automation India Pvt Ltd

Plot No: 5D, Sector-126, Expressway, Noida

Distt: Gautam Buddha Nagar, Uttar Pradesh 201 303

☎ 0120 – 429 5894 • Mob: 92051 82886

E-mail: info@reckersautomation.com

Rotating Electrical Connector

Progressive Engineers distributes Mercotac (USA) connectors that are ideal for Instrumentation, Robotics, Thermocouples, Cable reels, Strain gauges, Turntables, Testing and control devices, Windmills, Packaging equipment and heated roller packaging applications. Mercotac Rotating electrical connector communicates between Rotating PLC and stationary MMI without any disturbances e.g. Rotary filling, capping machines and different rotary packaging machines, continuous rotary equipments, robotic arm, Wind Mills and rotary assembly machines. It is also suitable for heated roller applications where precise temperature control can be achieved e.g. Blister Pack, Lamination Rollers, etc. Mercotac Rotating Electrical Connectors with flameproof enclosure are also available for flameproof applications suitable for Zone-1, Gas group I, IIA and IIB, T6.



Contact:

Progressive Engineers

C-228A, Ghatkopar Industrial Estate

Ghatkopar (W), Mumbai 400 086

☎ 022 – 4826 1011 • Mob: 92235 03903 / 98208 49478

E-mail: info@progressiveengineers.net

Powerful Batteries

Indus Power Industries Pvt Ltd manufactures Powerful Batteries – Tubular Batteries, Solar Batteries, and Inverter Batteries. The Indus Tubular Battery Features: Easy Main-

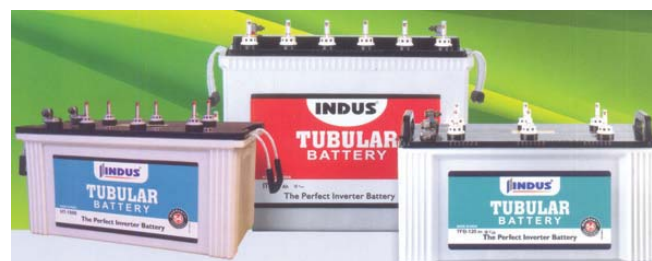

tenance; Latest Technology Tubular Battery for longer life; Built-in Fume arrestor; Tunes 1200 Cycles; Special alloys to withstand high temperatures; Superior Drain back design; Greater clearance. Tubular batteries are developed using the best in class technology and set the industry standards high. These batteries are vastly paired with inverters and are highly recommended for optimum functionality and output. The batteries have built-in fume arrestors and are much appreciated for its easy to maintain structure, greater clearance and rugged construction.

Contact:

Indus Power Industries Pvt Ltd

W-246/1 MIDC, Phase II, B/s: Abhinav Vidyalaya

Dombivli (East), Dist: Thane, Maharashtra 421 203

Mob: 81084 84848 / 81085 85858 • E-mail: sales@indusups.com

Easymech Premium Quality Drill & Endmill Resharpener Machines

In the competitive world of CNC machining, the decision between low-cost re-sharpener machines and high-quality alternatives is crucial. Many have been drawn to cheaper Chinese machines, only to face frequent break-



downs, high repair costs, and lackluster after-sales support, resulting in increased downtime and production halts. A standout solution offered by Mechmatrix is the Easymech Premium Series Made-in-Taiwan Drill – EndMill Resharpener Machine, a game-changer offering reliability, precision, and cost-effectiveness. Easymech's Taiwanese engineering ensures robust, heavy-duty performance with high precision components for accurate re-sharpener tasks. Its user-friendly design simplifies operations, significantly reducing the need for specialized training. Developed in response to real-world challenges struggled with the high costs and inefficiencies of a low-quality machine, Easymech offers a stark contrast with its durable, efficient, and cost-saving features. Easymech exemplifies the smart choice: over a decade of reliable service, minimal repair costs, and superior technical support. Investing in Easymech not only elevates the efficiency and satisfaction of CNC workshops but also ensures a significant reduction in total cost of ownership. Easymech stands as a strategic investment for CNC businesses aiming for long-term success, emphasizing the importance of choosing quality and reliability over initial low costs. Discover Easymech's innovative machinery at the Pune Machine Tool Expo - PMTX 2024 and transform your CNC machining process for increased profitability with Mechmatrix's advanced solutions.

Contact:

Mechmatrix

F-53, MIDC, Satpur, Nashik, Maharashtra 422 007

☎ 0253 – 669 8801, 669 8804 • Mob: 98223 03180

E-mail: salesmmx@mechmatrix.in

Subscribe to
Industrial Products Source
at ₹550/- for 2-year.

Material Handling Equipments

Technosys Equipments Pvt Ltd an ISO 9001: 2015 Company supplies a range of Material Handling Equipments like Basket Handling Pallet Truck (Capacity: up to 2500 kg), Bobbin Handling Pallet Truck (Capacity up to 1200 kg), Bobbin Loader – Pay-Off (Capacity up to 1000 kg), Battery Operated Bobbin Loader Pay Off (Capacity up to 1000 kg), Battery Operated Truck (Capacity up to 3000 kg), Twin Bobbin Handling Truck (Capacity up to 2500 kg), Drum Handling Trucks (Capacity up to 10,000 kg, and 20,000 kg), Wooden Drum Transporter (Capacity up to 10,000 kg), Basket Handling Truck (Capacity up to 3000 kg), Copper Pallet Handling Truck (Capacity up to 5000 kg), Electric Stacker (Capacity up to 3000 kg), Counter Balance Stacker (Capacity up to 3000 kg), Articulated Mast Forklift (Capacity up to 2000 kg), Hydraulic Scissor Lift (Capacity up to 30,000 kg).



Contact:

Technosys Equipments Pvt Ltd

Plot No: 144, Sector No: 10, PCNTDA, Nr: Vishweshwar

Chowk, Bhosari, Pune, Maharashtra 411 026

Mob: 99229 68480

E-mail: accounts@technosysequipment.com

FITZER

World Class Product Brand

PROCESS, MEASURING INSTRUMENTS & AUTOMATION

PRESSURE

- LIQUID COLOUR MANOMETERS
- DIGITAL MANOMETER
- DIGITAL PRESSURE GAUGES
- BAROMETER
- VACUUM MANOMETER
- PRESSURE SWITCHES

FLOW

- GLASS TUBE / ACRYLIC ROTAMETERS
- METAL TUBE ROTAMETER WITH TRANSMITTER / FLOW INDICATOR TOTALIZER
- BY-PASS ROTAMETER
- ELECTROMAGNETIC FLOWMETER
- FLOW SWITCHES
- AIR VELOCITY KIT

LEVEL

- LIQUID LEVEL INDICATORS
- LIQUID LEVEL TRANSMITTER
- LIQUID LEVEL SWITCHES (FLOAT OPERATED)
- CONDUCTIVITY LEVEL SWITCHES
- CAPACITANCE TYPE LEVEL TRANSMITTERS

FITZER ® Regd. Correspondence Address:
INSTRUMENTS COMPANY [INDIA] Atali, Near Ambivali Stn. (W), P.O. Mohone, Tal. Kalyan, Dist. Thane-421 102
Mobile: 8691816354 / 8691816355 / 8691816356 / 9426470248
E-mail: fitzerindia@hotmail.com / fitzergujarat@rediffmail.com

Dealership Enquiries Solicited
Website: www.fitzerindia.com

Transformers

Indus Power Industries offers a range of Transformers like Control Transformers – Range: 50 VA to 10 kVA; Can withstand wide voltage variations; Efficiency: Higher than 94%.

High Current Rectifier Transformers – Range: Up to 4000 Amp; Copper and Aluminium Conductors; Multiple Secondary windings; Efficiency: 97% or more.



Multi-Tapping Transformers – Range: Up to 600 kVA; Copper and Aluminium Conductors; Up to 32 Secondary's; Efficiency: 97% or more; Suitable for wide voltage fluctuations. Auto Transformers – Range: Up to 500 kVA; Used when isolation is not required between Input and Output; It has only one winding to step up or step down the voltage; Smaller and cheaper than Isolation Transformers. UPS Transformers – Range: Up to 300 kVA; Single Phase and Three Phases; Copper and Aluminium Conductors; Split or Double wound for impedance matching; Zigzag winding. Power



and Isolation Transformers – Range: Up to 750 kVA; Continuous operation under voltage fluctuations; K-Rated Transformers for harmonic loads; Ultra-Isolation feature on request; Three Phase Input and single phase output available; Efficiency: 96 to 98%.

Contact:

Indus Power Industries Pvt Ltd

W-246/1, MIDC, Phase II, B/s: Abhinav Vidyalaya Dombivli (East), Dist: Thane, Maharashtra 421 203

Mob: 81084 84848 / 81085 85858 • E-mail: sales@indusups.com

Steel Wire Products

Aarti Steel International Limited offers Steel Wire products such as Tyre Bead Wire for Auto and Cycle Tyres; High Carbon Spring Steel Wire – Black and Galvanized; HTGS Wire and Strand for ACSR Conductor; High Carbon Wire for Wire Rope – Black and Galvanized; Mattress Wire for Spring Mattresses; Music Spring Steel Wire; Stranded Galvanized Wire (Messenger Wire); SSRQ Wire – Black and Galvanized; Direct Drawn Wire; Rope Wire; etc.



Contact:

Aarti Steel International Limited

Focal Point, Ludhiana, Punjab 141 010

☎ 0161 – 5244 4200 • E-mail: aarti@aartisteelintl.com

FRP Customizable Field Control Solutions in Weather Proof Enclosures

Shrenik & Company manufactures a wide range of FRP Environment Friendly Enclosures. The range includes:

Junction Boxes (C&I) and Power Junction Boxes and Street Light Junction Boxes, Switch Socket Outlet, Local Control Stations, Multi Outlet, APFCR Panels, MCC Panels; Power Distribution Boards, Lighting Distribution Boards, Street light junction boxes, Power junction boxes, Control junction boxes, Feeder Pillar, etc. The FRP advantages: Light weight with high strength; Corrosion free and Impact resistant; Dimensional stability; electrically non-conductive; Non-magnetic and non-sparking; Low thermal conductivity; Rapid installation, RF transparency; UV Resistance; UL 94 certified. Protection Class of Enclosures: IP 54, IP 55, IP 65, IP 66.



Contact:

Shrenik & Company

39-A/3, Panchratna Industrial Estate, Sarkhej-Bavla Highway Changodar, Ahmedabad, Gujarat 382 213

☎ 02717 – 610 700 • Mob: 98258 03319

E-mail: sales@pustron.com

Electric Motors/Gear Boxes & Drives

Variation Electric Company Private Limited is an ISO 9001:

2015 Certified Company, and manufacturers and importers of a range of Electric Motors, Gear Boxes and Drives. The range includes: AC Geared motors, Inline Geared motors,



PMDC Geared motors, AC Induction motors, AC Synchronous motors, Helical Geared motors, BLDC motors and Drives, PMDC motors, DC motors; Gear Boxes, Planetary Gear Boxes, AC/DC Drives, etc.

Contact:

Variation Electric Company Private Limited

Plot No: 31, Karkhana Bagh, 16/2 Mathura Road Faridabad, Haryana 121 002

☎ 0129 – 401 8120 • Mob: 93118 08570, 98110 82255

E-mail: variationelectric@yahoo.com

Explosion Proof Rotary Switch

TRI-FLP Engineers Pvt Ltd (Trimurti) offers Explosion Proof Rotary Switch. Its Technical Specifications – Type of Ex-Protection: EEx-d Type, IS/IEC60079-1:2007; Zone Classification: Zone 1 & Zone 2; Gas Group: IIA, IIB & IIC T6 IS/IEC60079-0:2004; Ingress IP Protection: IP66 AS PER IS/IEC60529:2001; Material of contraction: High Pressure Die Cast Aluminium Alloy LM6; Paint: Epoxy Polyester Powder Coating; Earthing: Internal - 01 No, and External - 02 Nos; Cable Entry: 02 Nos. for M20 (3/4" ET); Hardware: Stainless Steel; AMP Rating: 10 Amp/16 Amp/20 Amp/25 Amp/32 Amp; Voltage: 110 volts/220 volts/500 volts/690 volts 50/60 Hz; Contact Type: ON+OFF 1 NO + 1 NC; Change Over Type: 1 Way/ 2 Way/ 3 Way/ with and without OFF. The Company manufactures Flameproof and Weatherproof Electrical Equipment. At TRI-FLP Engineers Pvt Ltd (Trimurti) ensuring security of human life is fundamental, that's why all their equipments conform to Flameproof and Explosion proof parameters. Moreover all their products are approved at CMRI Dhanbad, ERTL Kolkata, BIS Mumbai, CCOE Nagpur and are manufactured as per IS Standards. The products include: Junction Boxes, Instrument Enclosures, Light Fittings, Local Control Stations, Clean Room area Light and Control Stations, Panel Boards, Custom Enclosures, etc.



Contact:

TRI-FLP Engineers Pvt Ltd
 Gala No: 7, Gulmohar Park, Plot No: A-164, Phase-I
 MIDC Area, Chole Village, Opp: Suzuki Service Center
 Dombivli (East), Dist: Thane, Maharashtra 421 204
 ☎ 0251 – 243 3393, 244 0071 • Mob: 98926 85313
 E-mail: triflp@gmail.com

Pneumatic Products

ACE Flow Konzepts Pvt Ltd, an ISO 9001: 2015 Certified Company manufactures different range of Pneumatic Products for different applications. The products range are: Air Nozzles, Air Blowguns, Air Flow Vac; Air Wipes, Vortex Tubes, Machine Tool Cooler; Air Amplifier, Hand Vacuum Gun, Cabinet Cooler; Air Jets, Air Knife, Pneumatics Piston Vibrator, etc. Applications: Blowing; Drying; Cleaning; Cooling; and Material Flow. The Company has tie-up with AIRMASTERS, Spain and NAVCO, USA.

Contact:

ACE Flow Konzepts Pvt Ltd
 68A, New Empire Industrial Estate, Kondivita Lane
 J B Nagar, Andheri East, Mumbai 400 059
 ☎ 022 – 4973 8514, 2834 2079 • Mob: 88283 33947
 E-mail: info@aceflowq.co.in

Reverse Air Bag House

ABR Enviro Systems offers Air Bag House. The features are: reverse air bag house with filter bags being cleaned using counter flow of gases from opposite direction; the reverse air cleaning bag-house, collects dust that regularly forms into a hard 'dust cake' on the dirty side of the filter bag; this type of dust collector uses high-pressure cleaning air, blown in the reverse or opposite direction of the dust laden stream, to clean the dust cake; in a reverse fan cleaning dust collector, polluted air enters the filter bags from the inlet at the bottom and passes through the inside of the bag. Dust particles collect on the walls of the bag; and the reverse air stream can be used to clean one bag or one row of bags at a time. ABR is a consulting company for all types of air pollution control equipment and is a manufacturer and supplier of filter bags, cages.

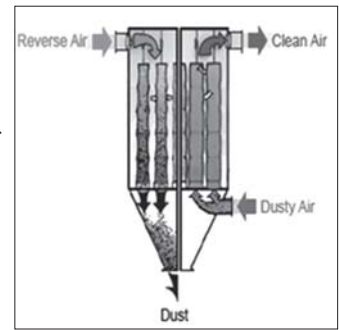

Contact:

ABR Enviro Systems
 2 Shri Krishna Apartment, 435 Alok Nagar, Kanadia Road
 Indore, Madhya Pradesh 452 001
 Mob: 93021 33960, 99931 77755
 E-mail: abr.systems@gmail.com

Miniature Compression and Tension Load Cell



Several Models

Fast Delivery

Hundreds of Satisfied Users

Any Application

Best quality Stainless Steel load cells for special applications such as Space Constraint Areas, Robotics, R & D, Automobiles, Keyboard Testing, Piano, etc. Capacities 0.1kg ~ 20,000kg at Low price.

Contact:

Haris Sensor Technologies Private Limited
 223, Shanti Industrial Estate, Sarojini Naidu Road,
 Mulund (West), Mumbai - 400 080 / INDIA.
 Tel: 022-2567 2205 / 2567 2147 / 2081 2013
 Mobile: +91-98200 84083

E-mail: info@haris.in | Website: www.harissensor.com

Fasteners & Components

Abhi Metals manufactures and exports fasteners and components. The fasteners and components are made from diverse materials, such as: Brass, Copper, Silicone Bronze,



Stainless Steel, Mild Steel, Aluminium, Naval Brass, Pune Tin, Titanium, Phosphorous Bronze, Aluminium Bronze, Tellurium Copper, Invar, Moly, Zinc Die Casting, and Be-



ryllium Copper. These products conform to various global standards, such as IS, ANSI, DIN, JIS, BS, AS and IFI. Abhi Metals Product Categories includes: Automobile parts, Machine Screws, Nuts and Washers, Hex Square and Flange Bolt, Components, Meter Parts, Pip and Serrated Screws, Customized Products, Knurling Insert, Sanitary Parts, Self-Tapping Screws, Furniture Screws, Stud and Grub Screws, Hooks and Rivets, Special Parts, Knurling Head Screws, Spacers, Hardware, Silicon Bronze Parts, Phosphorous Bronze Parts, Copper Parts, Tellurium Copper Parts, Aluminium Parts, Aluminium Bronze Parts, Titanium Parts, Invar Parts, Moly Parts, Zinc Die Casting Parts. Products Range – Fasteners: Dia 2 mm to 16 mm, Length: 3 mm to 225 mm; Components – Dia 1 mm to 300 mm, Length: 2 mm to 8 Ft.

Contact:

Abhi Metals

Plot No: 3957/58 & 3975/76, Road No: U, GIDC

Phase III, Dared, Jamnagar, Gujarat 361 004

☎ 0288 – 273 1260 • Mob: 93281 00667 / 93285 10667

E-mail: marketing@abhimetals.com

Elevator Automation Products

Excella Electronics specializes in Elevator Automation Products. The Company offers a range of products such as Door Detectors, Blowers, Axial Fans, Overload Sensors, Elevator Panels, Encoders, Phase Failure Relays, SMPS, Voice Annunciators, etc.

Contact:

Excella Electronics

213-217 Damji Shamji Industrial Complex

LBS Marg, Kurla West, Mumbai 400 070

Mob: 8425993536 / 9869231387

E-mail: sales@excellaelectronics.com

Shielded Battery Cables for EVs and Emobility

Elcab Conductors have successfully developed and tested shielded and screened battery cable for electric vehicles. Its Benefits: Conductor Class: 6; Conductor: Bare copper; Stranding: Back Twist Free Highly Flexible conductor made on SPMs. Insulation: Highly Flexible TPE or Flexible HR PVC in accordance with ISO 19642-5 and ISO 19642-9 (former ISO 6722 and ISO 14572) in accordance with LV 216-1, LV 216-2 and customised specifications. Colour: White or Orange; Separator: Aluminium Mylar Tape; Screening: Tinned Copper Braid with 85% coverage or as per customer design. Separator: Non-Woven Fleece; Sheath/Jacket: Highly Flexible TPE or flexible HR PVC in accordance with ISO 19642-5 and ISO 19642-9 (former ISO 6722 and ISO 14752) in accordance with LV 216-1, LV 216-2 and customized specifications. Colour: Orange; Rated Voltage: 6.6 kV AC, and DC; Minimum Bending Radius: Fixed – 5 times the OD; Flexing – 8 times the OD; Core to Screen IR: Over 100 G Ohms for 100 m for TPE, Over 200 M Ohms for PVC; Operating Temperature: 50 to 125°C for TPE; -40 to 105°C for flexible HR PVC; Cable Assembly/Harnessing: Can be done.



Contact:

Elcab Conductors

A-103 & 94, H-Block, MIDC, Pimpri

Pune, Maharashtra 411 018

☎ 020 – 4670 3001 • Mob: 97677 74447

E-mail: info@elcabconductors.com

Metallic Expansion Joints (Rectangular and Circular)

Mech Well Industries Ltd, an ISO9001: 2015 Certified Company offers Metallic Expansion Joints (Rectangular and Circular) to compensate for axial and lateral movements covering a wide range of operating conditions. Assemblies are offered in different corner configurations. The Rectangular/Circular Bellow assemblies are used in gas turbine exhaust systems, forced draft fans, flue gas ducts, regenerators, precipitators and other hot gas large volume ducting systems. Materials offered: CRCA, Corten, Stainless Steel, and Incoloy, thickness up to 3 mm (Higher thickness can be considered). To-date maximum size supplied is 11500 mm x 7000 mm.



Contact:

Mech Well Industries Ltd

7-A, Old Anijrwadi, Mazgaon, Mumbai 400 010

☎ 022 – 6620 0300 • E-mail: msil@mechwell.com

AC & AC+DC TRMS Digital Power Clamp-On Meter Model KM 099

KUSAM-MECO has introduced a New 'UL' listed AC and AC+DC Power Clamp Meter Model KM 099. Features: It has high safety Transient Protection of 8 kV; CAT III 1000 V AC and DC and CAT IV 600 V AC and DC; Overload Protection 1000 V rms for all functions (via terminals); and meets UL specification. The Jaw Opening is 51 mm. The DC voltage range is 60.00 and 999.9 V. The AC+DC Voltage range is 0-999.9 V. Total distortion factor AC V, DC + AC V-2% to 100%; Individual Harmonics order of AC V or DC+AC V – H 01-H-10, H10-H25; AmpTip Clamp on DC A 0-40 A; AmpTip clamp on AC A - 0-40 A; AmpTip clamp on AC+DCA – 0 - 40 A; Resistance 0-6.000 kΩ; Regular Clamp on DCA -999.9 A; Regular Clamp on AC+DC A – 0-999.9 A; Regular Clamp on AC A – 0-999.9 A; THD of Regular Clamp on AC A or DC+AC A - 2% to 600%; DF % of Regular Clamp on AC or DC+AC A 2% to 100%. Individual Harmonics order of regular clamp on AC A or DC + AC A - H 01 - H-25. KM 099 can measure Capacitance from 10.0 μF to 999.9 μF; and also has function of Diode and Continuity test. It can measure Temperature -40°C - 400°C (K-Type Temperature). It measures Single-phase and 3-phase Balanced Load Power. Range: 10 W - 999.9 kW; Apparent Power: 10 - 99.9 kVA; Reactive Power: 010 - 999.9 kVAR; Power Factor: 0.00 -1.00; AC+DC Power (VA) – 10 - 999.9 kVA; DC Current Range: 10-999 A; Hz Line level Frequency: 40-70 Hz, Non-Contact EF Detection: 10 V - 1000 V. It operates on 2 × 1.5 V AA Batteries. Weighs about 400 g and is supplied with Test Lead, Thermocouple, Manual, and Carrying Case.



Contact:

Kusam Electrical Industries Ltd
 Shop No: 18, 1st Floor, CIDCO Shopping Complex, Plot No: 9
 Sector-7, Rajiv Gandhi Marg, Sanpada, Navi Mumbai 400 705
 ☎ 022 – 2775 4546, 2775 0662
 E-mail: sales@kusam-meco.co.in

Subscribe to
Industrial Products Source
 at ₹300/- for 1 year.

Sensors

BCH Electric Limited offers Sensors like Inductive Proximity Sensors, Capacitive Proximity Sensors, and Photo Electric Sensors. Features of Inductive Proximity Sensors – Diameter: 4 mm to 80 mm; Sensing Distance: 0.8 mm to 40 mm; Flush and Non-Flush Version; AC 2 Wire, DC 2, 3 and 4 Wire versions. Features of Capacitive Proximity – Sensing Distance up to 25 mm; AC 2 Wire, DC 3 Wire and 4 Wire Versions; Sensitivity adjustment through multi turn potentiometer; Features of Photo Electric: Cylindrical and rectangular type; Diffuse reflective, Retro reflective and thru beam Emitter-Receiver; Sensing range: 50 mm to 10 m, AC and DC Versions. The Company's products range includes: Plug in Relays, Electronic Timers, Plugs and Sockets, Motor Control Center and Power Control Centers, Limit Switches and Foot Switches, Bus Ducts, Switchgear and Control gear, Power Controls, Wires and Cables, etc.



Contact:

BCH Electric Limited
 1105 New Delhi House, 27 Barakhamba Road
 New Delhi 110 001
 ☎ 011 – 4367 3100 • E-mail: marketing@bchindia.com

Thermocouples & RTD (PT100) Sensors

MI (Mineral Insulated) Thermocouple



Thermo Well



Magnetic Float Sensors



Die Head Thermocouple & PT100 (RTD) Sensors



CHNT

Contactor, OLR, MCB, MCCB, MPCB



Other Products: Photo Electric Sensors • Proximity Sensor • Mica Band Heater & Cross Head Heater • Nozzle Heater • Ceramic Band Heater • Tubular Heaters • High Density Cartridge Heater • Porcelain Heater & Element • Industrial Oven

BHEEMAS CONTROLS

55-D, 1st Floor, Grey Town, Dr. Nanjappa Road, Opp to Church, Coimbatore - 641 018
 Mob: 094431 29073 | 090420 98267 • E-mail: bheemascontrols@gmail.com
 Website: www.bheemascontrols.com

Motion Control & Automation Solutions

Hexagon Technology supplies a range of Motion Control & Automation Solutions. Their products range includes: Aero Motion Stepper Motor and Driver, HCFA High Performance AC Servo, Yakotech Easy Servo and Stepper, Tornex Precision Planetary Gearbox TRX and TR Series, Weihong Controllers, Richauto and DDCS Controller, Air cooled Spindle, Water cooled Spindle, CNC Plas-



ma Product, VFD (AC Drive), Ball screw and Accessories, Linear Rail & Block, Cable Drag Chain, Transformer and Rotary Gearbox, Rack Pinion and Pulley Belt, Drag Chain Duty Cable, etc.

Contact:

**41 Radhe Krishna Industrial Estate, Opp: Adarsh Silver Estate
Near Pelican Estate, Road No: 5, Kathwada GIDC
Ahmedabad, Gujarat 382 430
Mob: 95743 40160 / 97143 91645
E-mail: sales@hexagontech.in**

MS Flanges

Heet Steel India Private Limited, an ISO 9001: 2015 certified Company is one of the prominent manufacturers, exporters and suppliers of a wide range of industrial MS Flanges and Circles, MS Agro Parts, Profile Cuttings and Machine Parts. These are acclaimed for dimensional accuracy, chemical resistance, corrosion resistance and durability. The flanges come in various sizes ranging from ½ inch to 24 inches, conforming to both Indian and International Standards. The Company offers flanges of higher quality at competitive rates with prompt delivery.



Contact:

**Heet Steel India Pvt Ltd
311 Abhinav Arcade, Opp: Harekrishna Complex
Paldi, Ahmedabad, Gujarat 380 006
Mob: 98257 46451 / 98795 87375
E-mail: heelsteel@gmail.com**

Car Parking Geared Motors

Nextork Transmission Pvt Ltd offers Wanshsin Cr Parking Geared Motors. Specifications – Output shaft OD 22 mm ~ 60 mm; Power Range 0.2 kW ~ 7.5 kW. Features: High efficiency; Compact Design; High Torque; Maintenance free lifelong grease. The motors are suitable for Parking Systems like Puzzle Parking, Stack Parking, High Torque; and Maintenance free lifelong grease. The Company's products range includes: Compact Geared Motor, AC Geared Motor, Harmonic Reducers, Planetary Gearboxes, VFD Drives, Permanent Magnet Motors, Industrial Ceiling Fan Reduction Motor, Enduro Bevel Helical Gear boxes, Bevox Series Heli Bevel Gear Boxes, Worm Geared Boxes, Brake Motors, Crane & Hoist Duty Motors, etc.



Contact:

**Nextork Transmission Pvt Ltd
C110 Synthofine Industrial Estate, B/h: Virwani Indl Estate
Off Aarey Road, Goregaon (East), Mumbai 400 063
Mob: 75061 31333 / 98210 52381
E-mail: nextorktransmission@gmail.com**

Optical & Electrical Photo Sensor

Toshniwal Sensing Devices Pvt Ltd offers Optical and Electrical Photo Sensors. Optical technology based photo sensors it detect objects, changes in surface conditions, and

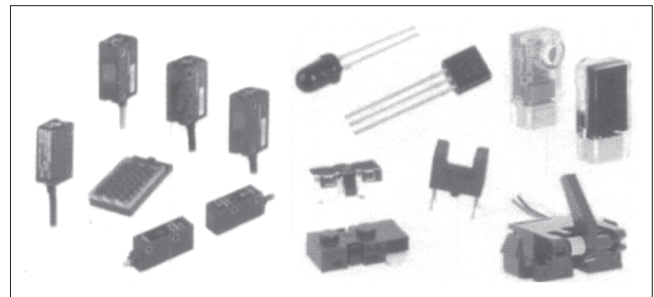

other items through a variety of optical properties. The Company has Photo Interrupter, Photo Reflector, Photo Interrupter-Separate type, Photo Interrupter-actuator type, Prism Photo Sensor, LED, Photo diode, Photo transistor. Photo Electrical sensor or photo eye, is equipment used to discover the distance, absence, or presence of an object by using a light transmitter, often infrared, and a photoelectric receiver. Applications: Vending machine, Bar code reading, Medical equipment, Mark detection, Coin/bill passage, Bill accepter, Object detection, and level detection.

Contact:

**Toshniwal Sensing Devices Pvt Ltd
D-30 Industrial Estate, Makhapura, Ajmer, Rajasthan 305 002
☎ 0145 – 269 5536 • Mob: 80037 79056
E-mail: info@tsdpl.com**

Oil Level Gauge

Rajshi Engineers offers Oil Level Gauge. It is used in Transformer and other Oil Tanks to measure Oil Level. Features: Rugged, Unbreakable, Transparent, UV Resistant; Gives easy visibility of Oil Level from distance; Easy mounting, by help of two hole in the tank; Design ensures leak proof assembly. Rajshi Engineers, an ISO 9001:2008 Certified Company offers a wide range of pressure relief valves, nitrogen filling breathers, and other transformer parts. The products are used in a wide range of applications, including power generation, transmission, and distribution. In addition to their products, the Company also offers a range of services to their customers. These services include: Design and engineering services: The Company can help customers design and engineer various transformer parts like Pressure Relief Valve, Oil Level Indicator and many others customized to meet your specific needs. Manufacturing and testing services: Rajshi manufactures various parts for transformers with both standard designs and customized needs along with testing them in their own Testing Lab. The Company also provides After-sales support.



Contact:

Rajshi Engineers
 2 BHEL Industrial Estate, PO: HEL
 Jhansi, Uttar Pradesh 284 129
 Telefax: 0510 – 277 0090 • E-mail: Rajshijhs@yahoo.com

Screws

Hisener Industrial Co, Ltd manufactures a range of Screws in Carbon Steel and Stainless Steel. The Range includes Wood Construction Screws, Chipboard Screws, Drywall Screws, Self-Drilling Screws, Roofing Screws, Self-Tapping Screws, Wood Screws, Decking Screws, Machine Screws, etc. The Company's other products: Threaded Rods, Bolts, Nuts, Washers, Anchors and Plugs, Welded Link Chain and Steel Wire Ropes, Wire Hooks, and Rigging Hardware.



Contact:

Hisener Industrial Co., Ltd
 13th Floor, Tower-B, Jinhui Building
 486 South HaiChang Road, Haining, Zhejiang, China
 ☎ +86 573 87379889 / +86 573 87379615
 E-mail: info@hisener.com

Hour Meters & Counters

GIC manufactures Hour Meters and Counters both analog and digital versions. Features: Hour Meter is an instrument that tracks and records elapsed time, normally displayed in hours and tenths of hours. The majority of Hour Meters are used to log running time of equipment to assure proper maintenance of expensive machines or systems. Just as Hour Meters measure running hours, Counters measure that frequency of occurrence or the number of units of specific items. Coupled with suitable sensing devices that provide the necessary pulse, counting the number of specific events or items is the simplest application of counters. Range includes: Wide Supply voltage; Panel, DIN Mount; Resettable and Non-Resettable; Multiple Bezel options; Frequency independent for AC applications; Ideal where space is limitation; Retentive and Non-Retentive modes. Applications: Generator and Compressor Panels, Earth Moving Equipment, Materials Handling Equipment, Tractors, Instrumentation Panels, etc.











Contact:

General Industrial Controls Private Limited
 T-107, MIDC, Bhosari, Pune, Maharashtra 411 026
 ☎ 020 – 4623 2323, 4623 2325
 E-mail: marketing@gicindia.com

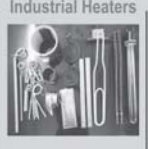

HIMA PRODUCTS

A HOUSE OF COMPLETE INDUSTRIAL HEATING SOLUTIONS

<p>Digital Temperature Controller</p> 	<p>Electrical Furnace</p> 
<p>Multi Point Temperature Scanner</p> 	<p>PID-Temperature Controller</p> 
<p>Thermocouples, RTDs</p> 	<p>Compensating Cables</p> 
<p>Industrial Heaters</p> 	<p>Electronic Timer</p> 

Other Products: Digital Voltmeter, Ammeter, Thyristor Motor Speed Controllers, Furnaces, Ovens, for Laboratory and Industries as per customer's specification.

HIMA PRODUCTS

P.B. No. 1630, # 186/1&2, Pushpanjali Tent Road
 Opp. K.R. Puram Railway Station, Doorvaninagar
 Bangalore - 560 016, India
Mob: 98457 70531 / 74115 63833
Email: himaproduct@gmail.com

Process Pumps

Abirami Engineering Company supplies Process Pump Type APO, which transfers pulp stock like water up to 7% consistency. Features – Design: Horizontal, Centrifugal, Single stage, Single entry, Radial split volute casing, Radial flow impellers pen type and the flanges in accordance with DIN/ANSI Standard. Operating Range – Capacity: Up to 3500 m³/hr; Head: Up to 150 metres; Temperature: Up to 240°C; Working Pressure: Up to 16 kg/cm²; Speed in RPM: 3000 max. Applications are in industries like – Paper: Apo type pumps are especially designed for handling pulp stock up to 7% without applying correction factor for Head and Efficiency; Sugar: To pump sugar juice, bagasse; Fertilizer: Chemical, Slurry, Contaminated liquids, Acidic/Alkalis/nature.

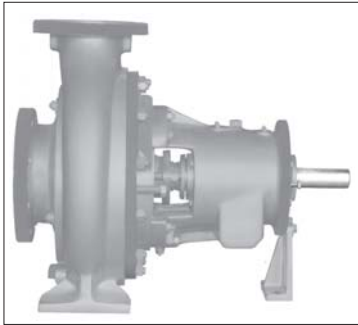

Contact:

Abirami Engineering Company
25 Vivekanantha Nagar, Street No: 1, PN Pudur
Coimbatore, Tamil Nadu 641 041
☎ 0422 – 244 3813 • Mob: 93631 45003 / 93623 45603
E-mail: abiramipumps@yahoo.com

Mini Super Melt

Megatherm introduces Mini Super Melt – a solution to insure you get what you pay for. It is an ultra-compact melter for Sponge Iron/Commercial Scrap. Features: Laborato-



ry application – ferrous and non-ferrous melting. High efficiency IGBT induction power supply provides fast melting. Available ratings: 5 kg to 25 kW and 10 kg to 40 kW. Light weight and installed in few minutes. No civil work; User-friendly controls and Noiseless operation. Optional LCD parameter display; and optional liquid metal weight monitoring.

Contact:

EMT Megatherm Pvt Ltd
1 Taratala Road, Kolkata 700 088
☎ 033 – 2401 4234, 2401 4325
E-mail: emt@megatherm.com

Coil Winding Machine

Acme manufactures and exports winding machines and accessories used in the field of winding applications. The Company produces Programmable Winding Machines in comprehensive range to meet customer's specific demand. Acme has various series of machines depending on its type of features and winding capabilities. AEX Series (*pix, top*) is a high speed winding machine with compact construction having single casting unit for robust mechanical operation and wider LCD for menu-driven programming with ease. Applications: SMPS and instrument transformers, WWR, Ignition coils, and Multi Section coils, Inductive coils, etc. AES Series (*Pix, bottom*) – a high accuracy winding machine for long axial winding length with servo motors and touch screen. Applications: Suitable for complicated, asymmetric, precise pitch control with variable values within single layer. Various optional accessories are available with standard machines to achieve specific winding applications.

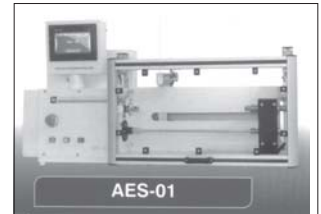

Contact:

Acme Electronics
780/A, GIDC Industrial Estate, Makarpura
Vadodara, Gujarat 390 010
Mob: 90999 28727, 82380 08788
E-mail: marketing@acmeengg.com

Industrial Fabric Welders

It is impossible to imagine life today without billboards or industrial fabrics - Whether it is classic billboards on buildings or at events, tents, covers, tarpaulins, architectural structures or Sunblind. It is always a product that was more than likely welded with Leister tools. Leister has always been at home in this important market and boasts unique know-how accordingly. The development of new tools is a top priority for Leister in this application area too. Alongside welding machines, hand welding tools from Leister are utilized here as well, together with matching nozzles and Leister's legendary pressure rollers. Hem welding, seam welding, pocket welding or rope welding, nothing is complicated for Leister. Leister welders are safe and productive welding, Simple with operating and welding aids, and durable and reliable.



Contact:

Leister Technologies India Pvt Ltd
4/27B Kambar Street, Alandur, Chennai 600 016
☎ 044 – 4558 3436 • Mob: 89398 17359 / 99629 96508
E-mail: info@leister.in

Continuous Laser Welder

Star Laser Technology offers Continuous Laser Welder. Fixed Light Path Laser Welder Series has peak power penetration capability, which results smooth welding effect with less heat affected zone. Laser welding is very much suitable for very thin metals as well as hard metals. This type of laser welding is commonly used in auto industries, transducers, electronic components, mobile industry, hardware, tools, utensils, etc.



Contact:

Star Laser Technology
28 Barcelona State, Nr: Odhav Ring Road Circle
S P Ring Road, Odhav, Ahmedabad, Gujarat 382 415
☎ 079 – 655 5595 • E-mail: starlasertech@gmail.com

Reactors, Autoclaves & Hydrogenators

Uni-Mech Industries manufactures Reactors, Autoclaves and Hydrogenators. Design Capacity and Range: Capacity: 250 litre to 100 kilo litre; Shell diameter: up to 5000 mm;



Pressure Range: Up to 120 kg/cm² (g); Temperature Range -80°C to 350°C. Special Features of Reactor: High heat and mass transfer area; Cutting down batch cycle time; Low power consumption; Capacity expansion; High mixing efficiency; Cost reduction in process operation. Types of Mixings: Liquid- Liquid mixing; Liquid-Solid mixing; Gas-liquid mixing; Gas-Liquid-Solid mixing; Homogenisation; and Wet grinding. Uni-Mech manufactures High Pressure Autoclaves; Hydrogenators; Jacketed Reactors; Limpet Coil Reactors; Homogenizer; Agitators (as per Process requirements) and Pharma Kettles, etc.

Contact:

Uni-Mech Industries
Plot No: C-14/15/53, Akshar Industrial Park
Opp: Zydus, Chacharwadi, Ahmedabad, Gujarat 382 213
Mob: 90990 87832 / 98250 23907 / 93746 23907
E-mail: ravidudhat@unimechindia.com

Second Screw Punches

B H Steel Industries is Sole Distributors for LCM Range of Fastener Tooling in India. LCM is a well renowned Taiwan based Manufacturer of Second Screw Punches, Pin



Punches, Hex 3pp Punches and other tooling for Fastener Forging applications. The Second screw punch range is from M0 - M12 and #0 - #12 with punch diameter 12 mm, 14 mm, 18 mm, 23 mm and 30 mm. These punches are available in two HSS material grades namely M2 and M42, wherein M2 is suitable for Carbon Steel and Alloy Steel, and M42 is suitable for Stainless Steel. BH Steel also has special coating technology applied to the punches to get additional life and performance.

Contact:

B H Steel Industries
A-601, 6th Floor, Raheja Point-1, Nehru Road
Opp: Vakola Church, Vakola, Santacruz (East)
Mumbai 400 055
☎ 022 – 6822 1100/6822 1180
Mob: 77200 10535
E-mail: bhi.steel@bhsteel.co.in

Acceleration Sensor

Monad Electronics offers Acceleration Sensors in a wide range. Features: High accuracy; High overload range; Multi axial high temperature range; SS, Alloy Titanium,



Aluminium Alloy Construction; Customized High End, High Accuracy Sensors; Strain Gauge, Piezoelectric/Resistive Technology, and IP67 Protection. This Sensor is suitable for Acceleration measurement and analysis; Vibration measurement; and Tilt measurement. The Company also offers Load Cells, Web Tension Load Cells, Solid Flow Meters, Wireless Dynamometers, Rotary Torque Sensors, Reaction Torque Sensors, etc.

Contact:

Monad Electronics
G1-805, Sitapura Industrial Area, Jaipur, Rajasthan 302 022
☎ 0141 – 277 1119 • Mob: 94140 68805
E-mail: mail@monadindia.com

Diffusion Welding Machines

Cyrus Industrial Solutions Private Limited, an ISO 9001-2015 certified organisation provides goods (traded and manufactured) as well as services as per the Global Standards to the Indian Industry in the field of Welding and Lifting. Their product range is used in various industries such as engineering, construction, oil and gas, power, steel and



many others and are known for their safety, durability, high-performance, low maintenance and heat and corrosion resistance. Diffusion is an accredited supplier of a wide range of welding machines, gas equipment, protective gear and compressed gases. The Company provides machines under following categories: MMA/ARC Welding; TIG/MMA Welding; Plasma Cutting Machine; MIG/MAG Welding; AC/DC Pulse TIG and MMA Welding; MIG/

MAG and MMA Welding. Diffusion Welding Electrodes: These are specially formulated electrodes for joining various types of ferrous and non-ferrous materials. The Company offers a complete range of products for maintenance and repair applications which enhance the life of industrial components. Our product range also includes consumables for Inconel, creep resistant and hard facing applications.

Contact:

Cyrus Industrial Solution Pvt Ltd
314-316 The Pentagon, Off Pune Satara Road
Nr: BSNL, Pune, Maharashtra 411 009
☎ 020 – 2421 6363 • E-mail: cyrus@cyrus.co.in

Electrical Control Panel

Pandiyans Industries supplies Electrical Control Panels, which are used to control packaged equipment. They contain enclosed electrical power control and operator devices designed and arranged to allow an operator to control a piece of equipment. The Company also undertakes Fabrication works, Electrical works, MS and SS Bending Job works, MS and SS Cutting Job works, etc.

Contact:

Pandiyans Industries
502/1 Rajiv Gandhi Road, Balamurugan Nagar
Ganapathy, Coimbatore, Tamil Nadu 641 006
☎ 0422 – 233 3929 • Mob: 99946 07929
E-mail: info@pandiyansindustries.com

Standard Multifunction Polisher r-SONIC

Riya Electrodes offers r-SONIC Standard Multifunction Polisher. Features: Power supply of AC 90-240 V at 50/60 Hz; High efficiency microprocessor with more flexible and user-friendly functions; Regulated power supply for low power consumption and overheating; Overload protective circuit and load indicator incorporated to enable safe and continuous usage; Ultrasonic function, DC rotary and DC brushless rotary functions incorporated in one single unit; High torque and high power output for DC and DC brushless motor output. Specifications – Maximum Power Consumption: 80 Watts; Ultrasonic Frequency Range: 18-26 kHz; Adjustment of Ultrasonic Output: Continuous; Ultrasonic Amplitude: 3-40 um; Suspension Detection and Protective Circuit; Output of DC Rotary Tool: 5-30 V DC Continuous adjustment; Output of Brushes DC Rotary Tool: 1,900-30,000 rpm, continuous adjustment; Overload Protection Circuit; Fuse: 2 A 20 mm Time-Lag; Dimensions: (W) 170 x (D) 240 x (H) 140 mm; and Weight is 2.5 kg.



Contact:

Riya Electrodes Pvt Ltd
SCF-30P, Part-1 Market, Sector-16A
Faridabad, Haryana 121 002
☎ 0129 – 4007956 • E-mail: riyainter@vsnl.net

Load Cells & Transducers

Monad Electronics supplies Load Cells and Transducers in wide range from 10 g to 5000 t. Features: High Accuracy, Reliability, Linearity, Rugged Construction, High Over-

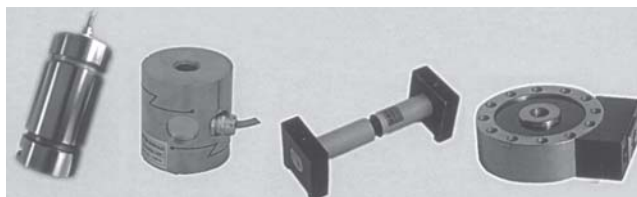

load Limit; Very Low Deflection; Overload Range: 150% to 1000%; Force, Load and Weight Measurement; Multi Ax-



ial High Temperature Range; SS, Alloy Steel, Aluminium Alloy Construction; Customized High End, High Accuracy Load Cell; Strain Gauge, Piezo Electric/Resistive Technology.

Contact:

Monad Electronics
G1-805 Sitapura Indl Area, Jaipur, Rajasthan 302 022
☎ 0141 – 277 1119 • Mob: 94140 68805
E-mail: mail@monadindia.com

Motion Control Products

Excella Electronics, an ISO 9001: 2015, 14001: 2015 and OHSAS 18001: 2007 Certified Company specialises in manufacturing and supplying motion control devices, indus-



trial electronic instruments, elevator control and safety systems and automation products. Through a strategy of continuous improvement and teamwork, the Company ded-



icated to establishing the highest industry standards for quality, value, service and technology. Excella offers Digital Instruments – Speed Monitors, Counters, Hand Tachometers, SMPS, DC-DC Converters, Battery Chargers, Incremental Encoders, Flexible Shaft Couplings, Sensors, Safety Light Curtains/Door Detectors, Static Eliminators and Electrodes, Electrodes (Anti-Static Bar), Stepper Mo-



tors, BLDC Motors, AC Motors, FHP AC Motors, AC/DC Tachogenerator, PMDC Motors, Miniature DC Motors, etc.

Contact:

Excella Electronics
213-217 Damji Shamji Industrial Complex
LBS Marg, Kurla West, Mumbai 400 070
Mob: 8425993536 / 9869231387
E-mail: sales@excellaelectronics.com

Fasteners Machinery

Aneja Allied Industries is a one stop solution for all kinds of fasteners machinery. The Company imports and supplies Fasteners machinery such as Bolt Masters, Nut Formers, Parts Formers, and Allied machinery.

Contact:

Aneja Allied Industries
Chandigarh Road NH-95, Nr: Kitty Bread, Kohara Chowk
Ludhiana, Punjab 141 112
Mob: 98886 88734 / 81959 00204
E-mail: info@anejamachinery.com

DC MIG/MAG/MMA Welder

Single/Three Phase

Prowin Techno Weld Equipments offers DC MIG/MAG/MMA Welder Single/Three Phase. Features: With good protection of under voltage, over voltage and over current, it makes the machine safe and reliable; Double IGBT high power module, high working frequency, efficiency and energy saving; High voltage slow wire feeding arc starting, no explode wire, removing tip arc ending; With CC/CV function, one machine with the MIG/MMA/Lift TIG; with 2T/4T working mode, convenient operation. Prowin's other products are: DC Plasma Cutter, MIG/TIG/ARC Spot Welding Machines, AC/DC 315 Inverter 3-phase Model; Arc/Gouging Welding Machine, Heavy Duty; Welding Accessories, and Service and Spares.



Contact:

Prowin Techno Weld Equipments
#65 B, Athipalayam Pirivu, Ganapathy
Coimbatore, Tamil Nadu 641 006
Mob: 94439 36115, 63698 63028
E-mail: info.prowin786@gmail.com

Fully Thyristorised MIG/MAG Welding System

Electro Engineers is an authorised distributor for Panasonic, and offers Fully Thyristorised MIG/MAG Welding System. Key Features: Synergic Mode (Unified Mode) is available for easy setting of current and voltage; Fresh tip treatment and burn-back time control are adjustable; Secondary short circuit protection is a standard function; Arc sensitivity is selectable by changing the tap of the reactor; Crater current and crater voltage controls on front panel; Crater Selection Switch, Gas Check Switch, Solid/FCW Selection Switch, Wire Diameter Selection Switch are available on the front panel; and Works on 50/60 Hz frequency in power supply. Other products offered by Electro Engineers: Thyristor-controlled DC Arc Welding System; Thyristor-controlled TIG Welding System, Fully Thyristorised MIG/MAG Welding System; Fully Digital CO₂ MAG Welding Machine; Full Digital Pulse MIG/MAG Welding System, IGBT Inverter-controlled Air Plasma Cutting System; Thyristor-Controlled Plasma Cutting System, etc.



Contact:

Electro Engineers
10/17 Keerthi Complex, Park Street, Kattoor
Coimbatore, Tamil Nadu 641 009
☎ 0422 - 437 9606 • Mob: 98422 76006
E-mail: electroengineers2000@gmail.com

Integrated Elevator Intelligent Control System

The INVT-EC-160A series controller is a new integrated Elevator Intelligent Control System, which integrates elevator control system and VF drive in one module thereby reducing the engineering effort, Interface wiring and thus saves valuable space. The INVT-EC-160A Integrated Controller adopts Advanced Closed Loop Vector technology, Intelligent Control technology and Distanced based Motion control. Main and Special Features: One-Drive – INVT-EC160 for Parallel, Serial, Geared and Gearless application; Direct to-Floor Landing through distanced based motion control and optimal Flight time; CANBUS for Serial Communication; Built-in PG Card for Geared and PM (Gearless) Motors; Static Auto-tuning for PM Motors (Gearless Machines); All inputs and outputs are user programmable to avoid replacement or repair of drive in case of failure of any Inputs/Outputs; Low Voltage Rescue operation with 230 V UPS with Light Load direction search to reduce Cost of ARD.



Contact:

Eletech Enterprises

**Sagar Signature Complex, Samkit Building, Gala No: 10
Opp: IPOL, Waliv Phata, Vasai East
Dist: Palghar, Maharashtra 401 208
Mob: 90821 55549 / 99204 12120
E-mail: eletech15@gmail.com**

Starter Panels

Sintex-BAPL offers Starter Panels for Agriculture applications: Pumps and Motors. Features: Shockproof and rust-proof; Fire retardant; Durable and lightweight; Weather-proof; Maintenance-free; Suitable for housing, mini DOL starter/star delta starter panel box along with ammeter, voltmeter, preventive devices and features. Range: Mini DOL starter panel box; DOL starter panel box; Single phase starter panel box; Three phase starter panel box; Pump panel house (Custom size available for all); Star delta starter panel box. Starter Panels are catering to: Government bodies in the field of agriculture and irrigation; Agriculture equipment manufacturers/suppliers and intermediates; and farmers.



Contact:

**Sintex-BAPL Limited
Kalol, Gujarat 382 721
☎ 02764 – 253 500 • E-mail: support@sintex.co.in**

Sigma Flex Manual Induction Cap Sealing Machine

Electronics Devices Worldwide Pvt Ltd is an indigenous company that deals in the manufacturing of high-frequency dielectric and induction heating equipment. Sigma Flex is specifically designed for laboratory use or batch production. This induction cap sealer is small in size and can be operated from a table top. It is also reliable to be operated for 24 hrs. Due to its light weight, it offers great portability. Sigma Flex is compact, but its advanced electronic design enables users to seal from cap 20 mm to 120 mm diameter with a single sealing head. This bottle cap sealer is ideal for start-up operations, manual production and offline testing. Sigma Flex can be plugged into a standard, single phase 230 VAC $\pm 10\%$ power outlet and is ready to operate. The timer can be set to the number of seconds required by your container for an effective seal. Heat induction sealer comes with a convenient case to be carried virtually anywhere for portable induction sealing needs. With over 45 years of experience in the packaging industry, their R&D team has many opportunities to apply Induction Sealing technology for various container shapes and sizes. As a result, customers can choose from a standard flat sealing head, tunnel sealing head or a customized induction sealing head for almost any closure design including CRC caps, Dome caps, Sports caps (Spout caps), Snap-On caps etc. Ease of operation and reliable performance are only a few reasons, why the Sigma Flex is preferred by factory managers and packaging engineers. If you have a product filled in a container, No matter what shape and size, we will seal it at your desired line speeds. Features: Portable; Digital Soft Touch Membrane Control Panel; Coax Cable; Digital Up/Down Timer; User Friendly; Continuous Use – 24 x 7; Versatile; and Fast, easy set-up. Sealing Capacity is (Avg. Output): 6 - 8 bottles/minute.



Contact:

**Electronics Devices Worldwide Pvt Ltd
31 Mistry Industrial Complex, Cross Road A
MIDC, Andheri •, Mumbai 400 093
☎ 022 – 2687 4629, 2687 0311 • E-mail: info@redmail.in**

Cartridges

MMP Filtration manufactures cartridges. The Company produces PP Melt blown Cartridge, Hydro wound (String wound) Cartridge, Pleated Cartridge, Filter Cage and Bag, Dust Collector Filter Bag, Polypropylene Yarn, Melt Blown Media. Quality is assured.

Contact:

**MMP Filtration Pvt Ltd
C-3-602, Anushruti Tower, Nr: Jain Derasar
S G Road, Taltej, Ahmedabad, Gujarat 380 059
☎ 70437 45709 / 80489 79719
E-mail: ahmd-sales@mmpfilter.com**

ACSR Wire

H D Wire (P) Ltd offers ACSR (Aluminium Conductor Steel Reinforced) Wire that consists of central steel wire strand at the center and Aluminium Wire Strand on the outer side. Steel Wire gives the strength and Aluminium wires gives good conductivity. The strength given by steel core helps in increasing the distance between two towers and is particularly helpful in hilly terrain and for river crossing. Without the strength of steel core the distance between two overhead transmission line towers will reduce considerably. Combination of good strength due to steel core wire and excellent conductivity from Aluminium imparts better strength to weight ratio. ACSR conductors made from ACSR wires are used to transmit the power from the power plants to cities and various consumption centers. Specifications – Dia: 1.50 mm to 4.09 mm; Zinc Coating: ISI/Commercial; Coil Weight: As per Required length; Standard: IS 398 Part-21 and 5 / as per customer specification. Applications: Used for mechanical re-inforcement in the manufacturing Aluminium conductor steel reinforced (ACSR); Cable and Conductor ACSR Core Wire is used in reinforcement of Aluminium conductors used in distribution and transmission of electricity.



Contact:

H D Wire (P) Ltd
17-20 Sector E, Industrial Area, Sanwer Road
Indore, Madhya Pradesh 452 015
☎ 0831 – 421 1199, 421 1124 • E-mail: info@hdwires.com

VFD & Soft Starter Panels

Omega Industries is a pioneer in the fields of design, manufacture, installation, process control and electrical control panels. The range includes VFD/Soft Starter Control Panels, Solar Control Panels, Compressor Control Panels, APFC Panels, and Draw out Panels, Instrumentation Systems and PLC Automation Panels. VFD and Soft Starter Panels: Adjustment of Speed of the Motor in an application, which is required in all the process industries and machine manufacturers, Variable frequency drive is used as energy saving device. For some of the machines to save power or it is used as final control element of the closed loop application where the speed of the motor is changed to control one Parameter.

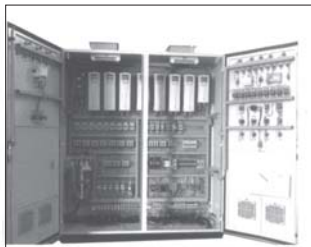

Contact:

Omega Industries
Plot No: 419B, 4th Main, 11th Cross, 4th Phase
Peenya Industrial Area, Bengaluru, Karnataka 560 058
☎ 080 – 2836 6600, 2836 2698 • E-mail: info@omegaindia.net

CNC Turning Machine, SINEWAY 2035

Global CNC Pvt Ltd offers CNC Turning Machine, SINEWAY 2035. Key Features: Roller Type Guideways; Ground Ballscrews with Double Nuts; FEM Analyzed Machine Structure; Operator Friendly Design; Vibration Free Structure; Elegant look of machine. Control System Features: RS-232 Serial Interface Port; Feed Rate Override; Manual Data Input; 2 Axis Simultaneous; Circular Interpolation; Thread Cutting Cycle; Electronic Hand Wheel; Tool Nose Radius Compensation; Constant Surface Speed Control; Part Programming Storage And Editing. Standard Features: Roller Type Guideways; Ground Ballscrews with Double nut; Foot Switch; Tool Holders; 8 Station Chuck with Actuating Cylinder; Patrol Light. Optional Features: Auto Door; Stabilizer; Chip Conveyor; Hydraulic Collet Chuck; Bar Feed System; All possible customization.



Contact:

Global CNC Pvt Ltd
Plot No: G-2617, Gate No: 1, Lodhika GIDC, Vill: Vad Vajdi
Tal: Lodhika, Rajkot, Gujarat 360 021
Mob: 90167 24955 • E-mail: sales@globalcnc.in

Reciprocating Surface Grinder with Horizontal Spindle

Alex offers Reciprocating Surface Grinder with Horizontal Spindle. Technical specification of Model BW1000 CNC – Grinding Area: 100 x 500 mm; Max Longitudinal table traverse: 1050 mm; Max Cross table traverse 550 mm; Max height of spindle center above table: 650 mm; Table size: 1000 x 500 mm; Max Table speed: 25 m/min; Cross feed resolution: 0.001 mm; Vertical in feed resolution: 0.001 mm; Grinding Wheel size: 350 x 127 x 50 mm; Spindle Motor: 15 HP (11 .25 kW); Hydraulic working pressure: 15 kg/cm²; Hydraulic Pump Motor: 3 HP; Hydraulic Tank Capacity (Machine base): 200 litres; Size of machine: 4300 x 2260 x 2300 mm; Net Weight of machine: 1,000 kg. Features: Fully Automatic Cycle – Rapid down feed from home position; Cross traverse feed; Automatic coarse infeed at each cross reversal; Auto dressing with Compensation; Cross traverse feed; Automatic fine infeed at each cross reversal; Dwell period; Auto retraction to home position; Demagnetization of the components – ready to unload.



Contact:

Alex Machine Tools
8 Gaiwadi Industrial Estate, S V Road
Goregaon (W), Mumbai 400 062
☎ 022 – 2874 3226, 2874 3744 • E-mail: amt@vsnl.com

P-TEF Wire

SSI Cables Pvt Ltd manufacturers and exporters of Wires and Cables introduced a newly developed Short Circuit Proof, Smoke Free, Flame Retardant and High-Performance

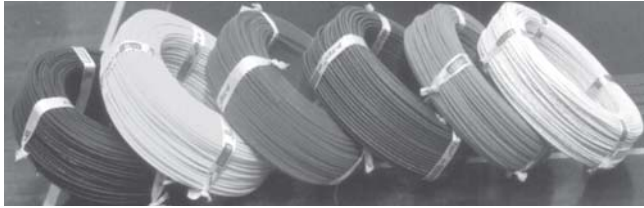

wire named P-TEF Wire. This is a combination of PTFE (Poly Tetra Fluoro Ethylene) and HFFR (Halogen Free Flame Retardant). This is a fire resistant, aging less, Electricity Saver, Chemical Resistant, Moisture Proof, Water Proof, High Load Bearing Capacity, Inert to fungus and mold growth, great High Surface Resistant, Good Flexibility and easy for handling. Applications: to protect building from fire accidents due to short circuit and save human lives. It is good for House Wiring, Panel wiring, Fire Alarms, Lifts, Electrical Doors, AC Fittings, D/C Battery Cables, Solar Panel Cables, Automobiles, etc.; and can be used where safety, high performance and long life of the wires are required.

Contact:

SSI Cables Pvt Ltd
A-19 Industrial Estate, Partapur
Meerut, Uttar Pradesh 250 103
Mob: 74648 00800, 90685 61661 • E-mail: info@sscables.com

TMT Rebar

Hulas Wire Industries is one of the largest steel manufacturing Companies and uses an automated TMT Bar Plant producing various sizes of TMT bars from 8 mm to 32 mm.

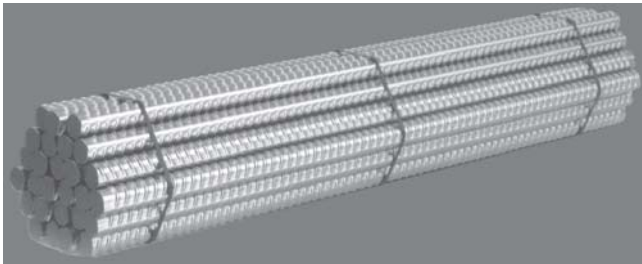

Hulas TMT Rebars are manufactured from high quality billet that is produced in house. The Company ensures the highest quality of steel rebar manufactured with automated process and superior grade quality materials with well-equipped Quality Laboratory. The Company's other range of products include: HR Strips, Galvanized Mild Steel Wire, Shutter Spring, Mild Steel Billet, Brass Coils, Strips, Foils and Sheets, which are used in Electronics, Telecommunications, Automobiles, Electrical industries, etc.

Contact:

Hulas Wire Industries Limited
Golchha House, Ganabahal, PO Box 363, Kathmandu, Nepal
☎ +977 - 452 0001 • Fax: +977-1-4249723
E-mail: ktm@golchha.com

Markmate Pneumatic Marking Machine

Asian Machine Tool Corporation Pvt Ltd offers Markmate Pneumatic Marking System, which is the flagship dot marking product and the Smartmark range. Fully programmable, highly configurable the Markmate Pneumatic is able to cope with any industrial dot marking application by virtue of its robust modular construction. The configuration option simply means the Markmate Pneumatic can be



built to meet a single range of marking application depending upon the user specific requirements. The class leading software ensures the system is easy to use. Unique head design guarantees the system is tough to last while operating in the most hostile of industrial environments. The modular construction ensures upgrade path are available to help future proof any system purchased. Features: Single Marking System for all Requirements; Quiet, Fast, Efficient Marking; Stand-Alone or Integrated; Wide Range of Options; 2D DataMatrix Code Marking.

Contact:

Asian Machine Tool Corporation Pvt Ltd
Gat No: 1239B, Office No: 3, 1st Floor, F-Wing
Mulshi Vaibhav, Opp: Pirangut Police Station
Pirangut, Mulshi, Pune, Maharashtra 412 108
Mob: 9011085733, 901074122 • E-mail: info@amtcl.com

Eco Flex Nylon Cable Ties

Novoflex, an IATF 16949: 2016 Certified Company, offers Eco Flex Nylon Cable Ties, which is a cost effective nylon cable ties for general application. Features: It is manufactured from Pure and

Virgin Nylon material. Colour: Natural White and UV Resistant (B), other colours available on request subject to a minimum Order Quantity (MOQ). Continuous Operating Temperature: -25°C to +85°C; Durable and Flexible; and Superior Toughness. The Company's products include: Polyamide Cable Glands, Security Seals, Flexi form Continuous Grommet Strips, Wire Harness Clips and Clamps, Cable Protection, Connector Back Shells, Tie Mounts, Cord Organizer, etc.

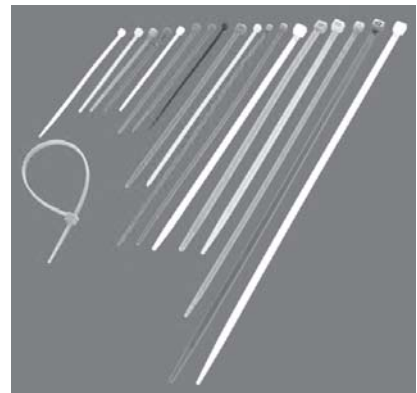

Novoflex Industries Private Limited
Raikva, 5th Floor, 3-A,
Ram Mohan Mullick Garden Lane, Kolkata 700 010
☎ 033 - 2372 0088 • Mob: 99031 63634 / 98314 63634
E-mail: sales@novoflex.in

Contact:

Novoflex Industries Private Limited
Raikva, 5th Floor, 3-A,
Ram Mohan Mullick Garden Lane, Kolkata 700 010
☎ 033 - 2372 0088 • Mob: 99031 63634 / 98314 63634
E-mail: sales@novoflex.in

Reed Switches

Reed Switches consists of a pair of flexible reeds made of a magnetic material, and sealed in a glass tube filled with inert gas. The reeds are overlapped but separated by a small gap. The contact area of each reed is plated with a noble metal such as Rhodium or Ruthenium, to provide the switch with stable characteristics and long life. Application of magnetic field, generated by a permanent magnet or a coil, to the reed switch causes both reeds to be magnetized. This produces an N-pole at the contact area of the one reed, an S-pole at that of the other reed. If the magnetic attracting force overcomes the resistive force caused by elasticity of the reed, the reeds come in contact (Pull-In) i.e. the circuit is closed. Once the magnetic field is removed, the reeds are separated again by the effect of elasticity of the reed (Drop-Out) i.e. the circuit is opened. The sensitivity of a reed switch is a measurement of the magnetic energy required to operate the switch. The unit of measurement is Ampere-Turn (AT), which is the current in a given coil, multiplied the number of turns on the coil. There are 30 different types of reed that include: General application, high power, high insulation resistance, low thermal emf, and mercury wetted. Reed Switches find application in vast areas like position sensing in doors; cell phones; satellite dishes, radio transmitters; microphones, automatic test equipment; copiers; scanners; appliances; security sensors; electronic energy meters; elevators/lifts; hoists, etc.

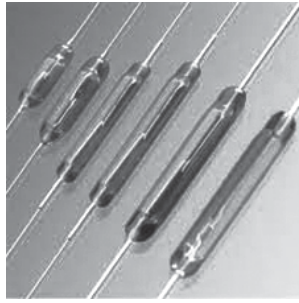

Contact:

VG Electric

27 Amrit Niwas, 2nd Floor, 165 K M Sharma Marg
Lohar Chawl, Mumbai 400 002
☎ 022 – 4006 0293 • E-mail: sales@vgswitches.com

Industrial Solar Batteries

Inova Battery offers Industrial Solar Batteries. Features: these are portable energy sources that can be transported conveniently anywhere; they help reduce electricity bills and the pollution footprint; some key benefits of the products are such as precise design; efficiency, and high functionality; and the material used in production is acquired from specialized sellers after strict testing for flawlessness and efficiency. The company's products includes: inverter batteries, UPS batteries, tubular batteries, solar batteries, automotive batteries, etc.



Contact:

Inova Battery

Gala No: 4, Mukesh Patil Compound, Sonar Pada Gaon
MIDC, Dombivali East, Thane, Maharashtra 421 201
Mob: 99870 76192, 97696 88180 • E-mail: ganesh75@gmail.com

Graphite Series VMC

S&T Machinery introduces latest Graphite Series VMC, meticulously designed to empower your machining capabilities with unmatched precision and innovation. Equipped with cutting-edge features and a specialized design for graphite machining, this VMC represents the future of precision engineering. Technical Specifications of Model VG 610 – X/Y/Z Travel: 640/450/500 mm; Table size: 800 x 450 mm; Controller: M80 V/Fanuc Oi-MF Plus/Siemens; Max Table Load: 500 kg; Spindle Speed: 8000 rpm (Opt: 10000/12000 rpm); Spindle Taper: BBT40; Transmission: Belt/Direct; Spindle Motor: 5.5/7.5 kW. Key Features; Ball screws special protected with internal wipers and Bellow covers; LM Roller Guide ways special protected type with wipers and covers for holes; Stainless Steel telescopic covers with moulded wipers in all axis; Guarding Special design for Graphite Package; Rear side Chip Disposal; Spindle Guard in Stainless Steel; Brush wiper in spindle guard; Coolant tank (Step down type for double filtration); Paper filtration system; Water Shield on the spindle; Mist Collector (Optional).



Contact:

S&T Machinery (P) Ltd

22/1A, Vasanth Nagar, Singanallur
Coimbatore, Tamil Nadu 641 005

☎ 0422 – 259 0810, 259 1470 • E-mail: info@stmnc.com

Repairing of Automation Products

Khushi Control System provides Repairing of all Automation Products, all types and makes of AC drives, DC drives, Servo Drives and Variable Frequency Drives (VFD), Soft

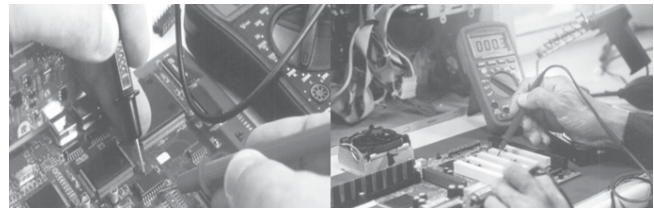

starters, Programmable logic control (PLC), Human Machine Interface (HMI) panels and operator panels of all brands. The Company has highly experienced team of experts, which works on root of PCB level of these automation products for repairing with its sophisticated instruments and quality testing unit. Also supplies all make AC Drive/VFD Spares – Power Card, Control Card, Display, Fan, Current Sensor, Capacitor, IGBT, Pre Charge Register, and Snubbers PCB.

Contact:

Khushi Control System

39 Rudra Estate, B/h: Rameshwar Estate, Nr: Mahadev Estate
CTM-Ramol Road, Ramol, Ahmedabad, Gujarat 382 449

Mob: 99245 33873, 99245 33360

E-mail: khushicontrolsystem@gmail.com

Tile Profile Roofing Sheets

Kamdhenu Steel Roofing Tiles are creative, strong and are versatile in function. Kamdhenu roofing tiles are the perfect blend of tradition with technology. They are made with advance modern technology and raw material made by international standards and yet do not sacrifice the traditional look of the roof. The roofing tiles have design benefits and are test-

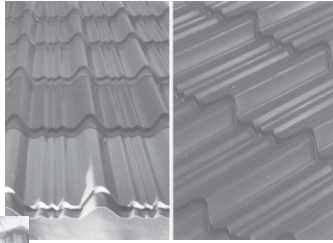

ed for harsh weather conditions. Kamdhenu Colour Max Tile range of roofing tiles complements the beauty of your building and also acts as shield in unfavorable weather conditions. Specially designed for hilly areas, the roofing tiles are ideal for high altitudes and cold weather conditions. Glossy finish and Matt finish are two different surface finishes to choose from for your roofing tiles along with entire world of attractive colours. Features of Kamdhenu Colour Max Tiles are: Corrosion resistant, thermal efficient and has appreciable sound dampening; Lightweight, easy to install, simplified handling; Attractive and comes with variety of colours and finish; Unique and have high strength to weight ratio; Environment friendly and can withstand extreme weather conditions.

Contact:

Kamdhenu Limited

2nd Floor, Tower-A, Building No: 9, DLF Cyber City

Phase III, Gurgaon, Haryana 122 002

☎ 0124 – 460 4500 • E-mail: sheets@kamdhenulimited.com

Portable Disintegrator – SPARKMAN

Sparkonix (India) Pvt Ltd offers Portable Disintegrator SPARKMAN, which fast remove broken taps, drills, and bolts. Mechanical Specifications – Usage: Metal Cutting; Input Voltage: 230 V AC, 50 Hz; Input Current: 9 A; Output Voltage: 75-80 V DC; Output Current: 20 A max; Electrode Diameter: 3-10 mm; Max Travel of Working Head: 100 mm; Water Pump Size (L x W x H): 50 x 55 x 65; Machine Size: (L x W x H): 500 x 250 x 350 mm; Net Weight: 20 kg. Sparkonix's other range of products include: Metal Arc Disintegrator, CNC EDM Drill, Smart Machines for High Performance; EDM Drill, Twin Head EDM; Tyre Mould EDMs, etc.



Contact:

Sparkonix (India) Pvt Ltd

B-4 H Block, MIDC Pimpri, Pune, Maharashtra 411 018

☎ 020 – 2747 0643, 2747 6452 • E-mail: info@spakonix.com

PUF Insulated FRP Roofing & Cladding Panels

Everest Composites Pvt Ltd (ECPL) has been a leading manufacturer of composite construction products for over three decades. ECPL is known for its strong technological capability, scalability, and adaptability, which have enabled the Company to stay ahead of the curve and meet the constantly changing requirements of the clients. The PUF Insulated FRP



Roofing and Cladding Panels have revolutionized the construction industry with their exceptional properties; and provide excellent strength and durability. The panels are also insulated with polyurethane foam (PUF) insulation, which enhances their thermal efficiency and makes them ideal for use in industrial and commercial buildings. These panels are lightweight, easy to install, and require minimal maintenance, making them a cost-effective solution for roofing and cladding. These panels are available in standard thicknesses of 30 mm, 40 mm, 50 mm, 60 mm, 80 mm, 100 mm, and 120 mm. The standard width of the panel is 1 m, and the maximum length is 12 metres. PUF insulated FRP panels are available in a range of colours and textures, giving architects and builders a wide variety of design options to choose from.

Contact:

Everest Composites Pvt Ltd

Block No: 15, Lamdapura Village, Tal: Savli

Dist: Vadodara, Gujarat 391 775

Mob: 98795 42289 / 99789 92929

E-mail: info@everestfibre.com

Shear Connector Studs for Arc Welding

Shear Connector Studs are designed to tie the concrete to the steel beams and to resist shear loading between the concrete slab and steel beam in composite construction. Length: Length is before weld. The shear connector studs, when welded to base metal will be approximately 5 mm shorter after weld. Lengths for shear connector studs are generally set by governing specifications. Metaforge can manufacture studs in other lengths and as per customer's specifications.



Contact:

Metaforge Engineering (I) Pvt Ltd

S No: 22/3, Nashik Dindori Road

Mhasrul, Nashik, Maharashtra 422 004

☎ 0253 – 253 0505

E-mail: mktg@metaforgeindia.com

Flat Submersible Cables (3-Core)

Empire Cable Industries Pvt Ltd is India's leading manufacturer of a wide range of electrical PVC insulated wires and cables, which are used by quality conscious electrical contractors and recommended by leading consultants, architects, builders for projects, domestic, industrial and agricultural wiring for trouble free working. These connecting cables are used for submersible pump motors. These cables are manufactured keeping in mind the severe and difficult conditions in which they are required to perform. The individual conductors are made from bright electrolytic grade copper; and drawn, annealed and bunched properly to ensure flexibility and uniform resistance. Each of the 3 copper conductors is insulated with special PVC compound. The cores are laid up in flat parallel position. The outer sheath of the cable is made from a special grade of abrasion resistance PVC compound impervious to water, grease, oil, etc.

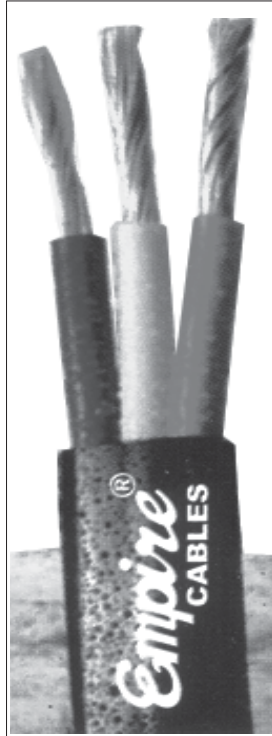

Contact:

Empire Cables Industries Pvt Ltd
115 Phase II, Badli Industrial Area, Delhi 110 042
☎ 011 – 2789 3424, 2386 8832
E-mail: empirecables@yahoo.co.in

Peripherals for Industrial Automation

Shavison Electronics Pvt Ltd offers range of Peripherals for Industrial Automation. The products are: Single Output SMPS, Dual Output SMPS, Open Frame SMPS; Bat-



tery Chargers, Power Distribution Modules, Hooters, DC UPS, Redundancy/Paralleling Modules, Analog Timers, Digital Timers, Analog Signal Converters, Protection Relays, FRC/D-Sub Connector Cables, Diode/Resistor Modules, Opto Interface Modules, DC-DC Converters, SSR Modules, etc.

Contact:

Shavison Electronics Pvt Ltd
Unit No: G-5/6, B-Wing, Plot K-3, Udyog Bhavan No: 2
Anand Nagar MIDC, Ambernath (E)
Dist: Thane, Maharashtra 421 506
☎ 0251 – 262 0417 • Mob: 98203 62980
E-mail: shavison@shavison.com

Extensive Dust Collector Machine

Purus Filtrotech Pvt Ltd offers a wide range of extensive dust collector machine. The features are: this dust collector machine is designed using supreme quality components and innovative technology by the skilled professionals; moreover, the collector machine is strictly tested by its quality controllers in line with set industry norms. Owing to its varied quality specifications, like accurate size and flawlessness, the dust collector machine is highly appreciated among the clients; its features include: robust design; accurate dimensions; optimum finish. The company is a manufacturer and supplier of effective environmental pollution control solutions in varied technical applications.

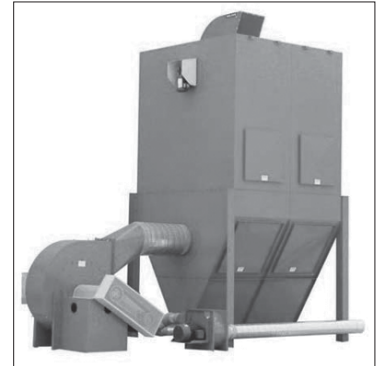

Contact:

Purus Filtrotech Pvt Ltd
81/4B, NDA Road, Shivane, Tal Haveli
Pune, Maharashtra 411 023
☎ 020 – 6522 4499 • Mob: 90216 02131, 78752 76339
E-mail: info@purusfiltrotech.com

Hybrid Solar Power Plant

Powermax offers a wide range of off-grid/Hybrid Solar Power Plant. The Company designs, develops, constructs, and installs off-grid solar and hybrid solar power plants for their esteemed clientele. These systems effectively combine the benefits of solar power generation systems, making them a smart choice from economic and environmental perspectives; installing off-grid or hybrid power plant systems in any other company premises helps generate free electricity from the sun without a need for maintenance and constant refueling; it provides a host of distinct benefits, including: helping reduce energy costs; low maintenance; a reliable and cleaner source of energy; saving on fuel costs; and these are available in models: 1 kW-100 kW. Powermax inverters and UPS systems is an ISO-certified company that manufactures, exports, and trades a wide range of home UPS systems and batteries.



Contact:

Powermax Energies Pvt Ltd
B-101 Apollo Tower, Bajiprabhu Deshpande Marg
Vishnu Nagar, Naupada, Dombivli (E), Dist: Thane
Maharashtra 421 201
Mob: 93222 82181 • E-mail: sales@powermax.co.in

Fiber Laser Cutting Machine

Fine Worth Engineering & Service offers Fibre Laser Cutting Machine. Its Features are: Heavy industry bed ensures the machine runs stably, light casting gantry makes it works faster. Perfect industrial design is more in line with man-machine engineering; High quality electrical accessories, Intelligent control system gives equipment higher cutting precision higher cutting efficiency and wider application scope; Intelligent alarm system auxiliary gas low pressure alarm function, providing real-time pressure direction, Ensures the cutting performance, accuracy and timeliness of gas replacement. Improve the equipment troubleshooting efficiency; Benefit of Ether CAT Communication. Because messages are passed before being processed in each node, Ether CAT operates at a high speed and efficiency. The process also creates flexibility in topology and incredible synchronization. Outside of the advantages gained from Processing on the fly. It benefits from superb infrastructure. Specifications of Model FGW-3015/FGW-4020/FGW-6525 – Work Area: 1500 3000 / 2000 x 4000 / 2500 x 6500; X, Y Position Accuracy: ± 0.03 mm; Z-Axis: Separated siding unit (10 m/min); Laser Power Supply: 1000 W – 6000 W; Laser Power Source: RAYCUS/IPG/MAG; Maximum Acceleration: 0.6 G; X, Y Drive System: Yasaka Drive (Ether Cat Communication); Cooler for Power Source: Available up to 2 kVA; Service Support: Raycus India.



Contact:

Fine Worth Engineering & Service

No: 2/690, Kullathur, Irugur Road, Chinnampalayam

Coimbatore, Tamil Nadu 641 062

Mob: 99444 43062, 88700 48444 • E-mail: info@fineworth.com

Hepa Filters

Chemietron Clean Tech offers Hepa Filters. The features are: the offered high efficiency particulate arrestance filter is specially designed for filtering air. They supplied a high efficiency particulate arrestance filter that is commonly used in medical facilities, homes, and aircrafts; its features include: mat of randomly arranged fibers; anti-microbial filter; low maintenance. The company is a manufacturer, supplier, trader, importer, and exporter of a range of clean room equipment.



Contact:

Chemietron Clean Tech Pvt Ltd

Shyamal, Karnavati Club, FF-9, Devnandan Avenue

B/h: Seema Party Plot, 100 ft Road, Satellite

Ahmedabad, Gujarat 380 015

☎ 079 – 6521 8306 • Mob: 98250 73114, 92272 19462

E-mail: chemietron@hotmail.com

Solar Generator, Model NOVA-AC300

Novasys Greenergy Pvt Ltd offers Solar Generator, Model NOVA-AC300. Its specifications and features: Type PWM Solar Charge Controller; SPV: 150 Wp/75 Wp x 2 Panels; Solar Charge Controller – Type: PWM; Max PV Open Circuit Array Voltage: 22 V DC; Charge Algorithm: 3-Stage Bulk/Acceptance/Float Plus Equalize; Charging Time: 8-10 hours full charged by solar panel (Under Efficiency Sunlight); Output – Output Voltage: 230 V AC $\pm 10\%$ (Modified Sine Wave); Output Watt Capacity (watts): 300 W (Tube, Fan, TV, Etc); Duration Time: 6 hours (Average load 100 W); General – LEDs Indications: SPV ON, Battery Low, Battery Level 25%, 75%, 100%; Protection: > 200% Over Load; Cooling Method: Air Cooled; Housing Material: Powder coated/Painted MS; Environmental – Operating Temperature Range: 0°C to 50°C; Relative Humidity: 95% (non-condensing); Degree of Protection: IP20; Battery – No of Battery: 1 x 12 V/54 AH/LiFePO4 Lithium Battery; Battery Charging Profile (Boost/Float): Suitable according to Battery Type; Max Charging Current from SPV: 8.75 A ± 0.5 Amp; Certifications – Product Warranty Period: 2-Year Limited Warranty.



Contact:

Novasys Greenergy Pvt Ltd

5 Ashirwad, HB Town, Old Pardi Naka, Bhandara Road

Nagpur, Maharashtra 440 035

Mob: 71226 83106 / 71226 783108

E-mail: sales@novasysgreen.com

Packing Machine

Shabnam Industries offers Packing Machine with features like: Operating cycle of the Blister Packing Machine is completely automatic and the use of continuous motion principle permits high speed and efficient packaging production; the fully automatic tablet feeding unit with Photo-Level control and vibrator guarantees positive filling of blisters with minimum deposition of dust and the sealing surface; Guide tracks between blister forming unit and sealing unit provides essential space for visual inspection of missing tablets. Patented and attractive sealing pattern is crease proof and eliminates capillary formation of aluminium foil sealing.



Contact:

Shabnam Industries

No: 798, Industrial Area-B, Ludhiana, Punjab 141 003

Mob: 97811 20297, 98140 21696

E-mail: exports@shabnamindustries.com

EOT Cranes

Vogal Engineering Industries offers an extensive range of EOT Cranes. These are accurately designed as per the defined quality standards under utmost care of professionals. These equipments are also capable to operate at unfavourable situation. These are widely acknowledged for



its long serviceability, optimum performance and optimized cost. Specification – Capacity: 1 ton to 50 tons; Usage: all movements are operated electrically. Applications: Hoisting and lowering of heavy loads; Right and Left movement of heavy loads; Reverse and Forward movement of heavy loads. The Company is pioneers in the fabrications of Lifting equipment, Industrial Lifting Equipment and Material Handling equipment, widely used in numerous industries. Vogal's products range includes: EOT Double Girder Crane, Single Girder EOT Crane, Gantry Crane, Over Head Mono Rail Travelling Trolley, Jib Crane Light-Crane System, Electrical Wire Rope Hoist, HOT Single Girder Cranes, etc.

Contact:

Vogal Engineering Industries
45 Luna Factory Plastic Road, TVS Nagar
Coimbatore, Tamil Nadu 641 025
☎ 0422 – 223 1854 • Mob: 94437 93034
E-mail: vogalindustries@gmail.com

Angle Linear Guideway - Hiwin AG Series

IBK Engineers Pvt Ltd offers Angle Linear Guideway Hiwin AG Series. The features are: it eliminates fastener plates for saving equipment weight and increasing work space; two rails are machined with precision in relative straightness. Extremely high accuracy in orthogonality is achieved; the rigidity of the AG block is 50% higher than that of a combination of two HG blocks secured together back-to-back with bolts. The company is engaged in the wholesaling, supplying, distributing, and trading of deep groove ball bearings, mechanical bearings, roller chains, components, electric equipment, etc.

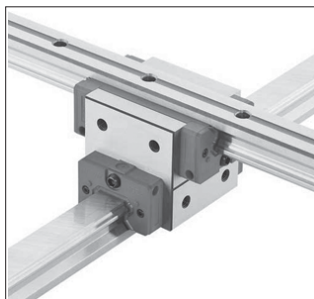

Contact:

IBK Engineers Pvt Ltd
B-219, 4th Cross, 1st Stage, Peenya Industrial Estate
Bengaluru, Karnataka 560 058
☎ 080 – 2632 1112 • Mob: 98805 66644
E-mail: rajukn@ibizkart.com

Inline SIVTEK Low Headroom Separator

Galaxy Sivtek Pvt Ltd offers Inline SIVTEK. It is a unique high efficiency and low headroom separator. This is made possible by developing a unique design that generates three dimensional motions

and allows maximum throughput of material. Benefits: Low headroom design that easily fits into existing product lines; Low manpower and maintenance costs; Feeding



Inlet and material discharge outlet in same centerline helps in reduction of process time by reducing the movement of material. User-friendly: Very easy to operate; Inlets and outlets can be customized to meet existing plant requirements; Available with Clean in Place systems; and Quick mesh change system. Available Options: Mobile stand for easy in-plant movement; Bag dump system provides dust control when loading material, minimizing contamination of the environment and safeguarding the health of workers; Grid magnet at Inlet/Outlet to remove iron contaminants during the screening process. Three standard sizes with 18", 24", 30", 40", 48" and 60" diameter to meet screening and separation needs (Dual motor option available on request). Applications of Inline SIVTEK: Bag emptying above mixers; Agglomerate and foreign matter removal; Off-line screening and product reclaim; Ingredient screening; Pre-packaging screening, and many more.

Contact:

Galaxy Sivtek Pvt Ltd
Plot No: 1406, GIDC Waghodia
Dist: Vadodara, Gujarat 391 760
☎ 02668 – 262 970 • Mob: 9227441209
E-mail: inq@galaxysivtek.com

Mica Band and Nozzle Heaters

Sri Balaji Heat Engineers offers Mica Band and Nozzle Heaters. Features are: a proven design for good life efficiency and dependability; specially selected mica grades and thicknesses are used to insulate windings, providing excellent thermal conductivity and dielectric strength; a specially treated rust-resistant steel sheath; high emissivity; and good thermal conductivity for heated cylindrical parts. The company makes all kinds of industrial heaters, like air heaters, long-life finned U-shaped air heaters, strip heaters, strip-finned heaters, cartridge brass heaters, etc.

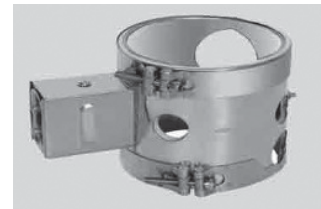

Contact:

Sri Balaji Heat Engineers
Phase V, Rami Reddy Nagar, Jeedimetla
Hyderabad, Telangana 500 055
Mob: 98486 16195
E-mail: sribalajiheatengineers.com

Vibrating Fork Switch BT-TFS-XXXX

BROTEK Smart Vibrating fork switch is available with in-built programming display to set switching point against Piezoelectric crystal frequency, fork body is excited by a

piezoelectric crystal, so that the fork body is in a resonance state. When the fork contacts the material, the resonance frequency will change significantly. The internal electronic unit detects the frequency of the fork body and after processing, converts it into a relay or a PNP. It is a new generation Vibrating Fork Switch with full independent property rights developed by BROTEK after many years of hard work. Features: Real-time display of fork frequency value; Supports both long and short tuning fork shapes for a wide range of applications; No need for on-site calibration; Self-diagnostic function; Easy to set: Sensitivity and alarm delay; the Quick Dripping shape design for faster response;



Not affected by flow, foam, turbulence, floating foam, vibration, solid content, hanging materials, liquid characteristics and media changes. Applications: Vibrating fork switches are commonly used in industrial and process control applications to detect the presence or absence of liquids or bulk solids in pipes, tanks, or vessels. These switches are often used in where other types of sensors, may not work well due to factors such as conductivity, dielectric constant, or buildup of material on the sensor surface. Some examples are: Chemical and Petrochemical Processing Plants, and Refineries, Food and Beverage Processing, Water Treatment Plants, Pharmaceutical Manufacturing, Wastewater Treatment Plants, Mining and Material Handling.

Contact:

BROTEK Industries
F-13, 1st Floor, Nilkanth Estate, B/h: Dediyanan GIDC
Mehsana, Gujarat 384 002
☎ 02762 – 255 234 • Mob: 82003 21923 / 84014 92220
E-mail: kishan@brotekswitch.com

Railway Plate Screws

Rail Udyog offers Railway Plate Screws. Features are: designed with high precision and processed under advanced technologies, the screws are manufactured using high-grade raw materials satisfying all the quality standards; with reliability, robustness, and effective performance, and can ideally be used in railway engineering. The company manufactures and supply of railway products.

Contact:

Rail Udyog
20/1 Shalimar Road, Near Shalimar Railway Station
Howrah, West Bengal 711 103
Mob: 80373 03443 • E-mail: rail_udyog@yahoo.co.in

Online UPS

The Indus Online UPS range provides you with a reliable source of uninterruptible power even in the most demanding environments. Configured with matching battery packs, this range of UPS can comply with your aggressive runtime demands. Features: Rugged design for tough Indian environmental condition; State-of-the-art technology; Customization and upgradation easily possible. Advanced Technology: DSP based control for power and monitoring; IGBT inverter technology for highest reliability; High efficiency; Pure sine wave output; Excellent voltage regulation and Transient response; Diesel Genset compatible; Wide Input Range; Heavy duty charger; Auto/manual bypass mode selectable; Engineered Design, Easy for Maintenance and minimize MTTR; Perfect protection against all faults displayed on LCD with alarm function; Excellent load feature, it is completely capable to load from 0-100%; Specifications can be customized.. Applications: Information Technology; Solar/Wind Power Generation; School and colleges; Telecom Sector; Satellite Earth Stations; Banking; Defense; R&D Centres; Bio-Medical Equipment; Industrial Instrumentation; Other Specific applications.



Contact:

Indus Power Industries Pvt Ltd
W-246/1, MIDC, Phase II, B/s: Abhinav Vidyalaya
Dombivli (East), Dist: Thane, Maharashtra 421 203
Mob: 81084 84848 / 81085 85858 • E-mail: sales@indusups.com

Bag Filtration System

Radiant Thermal Engineers offers Bag Filtration System. The features are: offered in various technical systems; this system is used to reduce boiler flue gas exhaust pollutants to up to the norms of the local pollution control board; this system is manufactured under the strict guidance of the the Company's deft professionals using premium quality components and the latest techniques. In addition to this, Radiant is providing this bag filtration system to the customers in various technical specifications at the most reasonable prices; its features include: energy efficiency; longer service life; superior performance; easy changeover of filters. The company is a leading manufacturer, supplier, and service provider of a number of boilers and heat exchangers for industrial applications.



Contact:

Radiant Thermal Engineers
Sector A, Sanwer Road Industrial Area, Indore, M P 452 003
Mob: 94240 18370 • E-mail: radtherm@rediffmail.com

Turbine Ventilator

Supreme Fibre Glass offers Turbine Ventilator. Ventilation is simply the process of supplying a continuous flow of fresh air through a space; this is accomplished by system of intake and exhaust. The Supreme Turbine Ventilator is a combination of both natural and forced ventilation system. It functions as a natural ventilator when there is a difference in thermal or wind pressure between the inside and outside of the building, which forces the air to move through the opening of the ventilators. It also acts a forced ventilation system when the turbine rotates to create a negative pressure with the factories. Cooler air from the outside will rush into the negative pressure space within the factories in order to maintain an equilibrium condition. Features: Rigid roll formed curved vanes; Weather proof and storm proof; Rotor shaft and bearing assembly concealed in aluminium or SS casing; Easily field replaced; Virtually maintenance free; Light weight and durable; Available in Aluminium and Stainless steel. Advantages: Safe as it does not require electricity. No pollution as it uses natural air; Easy to install on any type of roof; No noise as using supreme bush; Rainproof as designed to protect from rain; Helps remove stale, damp and hot air – increases workers' productivity; Saves the energy – Supreme turbine ventilator operates utilising the slight energy of the wind, so it saves power cost; Prolongs life of machines, ventilators can extract dampness in the air out of the building, which results in machine and other electrical system can work at their fullest efficiency and prolongs their life; 100% depreciation.



Contact:

Supreme Fibre Glass Pvt Ltd
Unit 19, Gr Floor, Keytuo Indl Estate, Kondivita Village Road
Nr: Pidilite Industries, Andheri (E), Mumbai 400 059
Mob: 98339 41241, 98673 17454
E-mail: supremefibre@gmail.com

Roboplast

Robo Silicon offers Roboplast. Products and process innovation are at the heart of everything they do at Robo Silicon. They are proud that this drive to innovate has led the Company to launch another first in the form of Roboplast for brick-working. Since the company's establishment in 1999 and subsequent product launch in 2001, the endeavor has been to offer the best in every aspect – be it mining, quarrying, processing, or the delivery of the products.

Contact:

Robo Silicon Pvt Ltd
402, 4th Floor, Sri Durga Towers, Road No: 10, Avenue 4
Banjara Hills, Hyderabad, Telangana 500 034
☎ 040 – 4546 7210 • E-mail: robosand@robo.co.in

Building Automation System Cables

Electro Cables Industries offers Building Automation System Cables. Multiplexes, malls, and high rise buildings are the norm of the day. A full complement of cables for control, connectivity, alarm, security, sound, water sprinklers, CCTV cameras, and building management systems are required. A system failure due to malfunction, loss of continuity, or poor workmanship of quality and material can be catastrophic; quality must be defined as conformance to the exacting requirements, not merely aesthetics; selection of the best raw materials and pre-manufacturing shop floor testing to give zero-defects performance; designing, processing, and inter-stage checks during progressive manufacturing are hallmarks of quality; and final product rigorous testing for quality is the motto of the company's dedication to total quality as conformance to applications. The company is one of the leading manufacturers of wires and cables and caters to the diversified needs of valuable customers.

Contact:

Electro Cables Industries
Plot No: 41-B-42-43-A, Electronic Complex
Pardeshipura Colony, HIG Colony,
Indore, Madhya Pradesh 452 001
Mob: 94794 45990 • E-mail: skjain@wincables.com

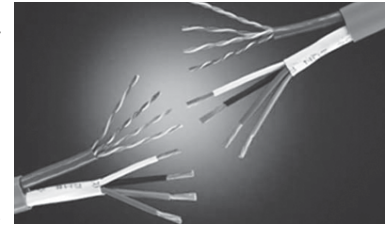

Power Cables

Empire Cable supplies power cables with PVC insulation for power transmission. Voltage grade 650/1100 volts (Uo/U) provided with ISI marking IS 1554 (Pt-1), with or without HR/FRLs properties. Screening can be provided if desired. The cables conform to standard specifications like IS 1554 (Pt-1), IEC 502, BS 6436/87. Configuration: Single core up to 1000 sq mm, multi-core up to 400 sq mm x 3-1/2 cores; Construction: Conductor is aluminium/copper, solid/stranded circular/compacted/sector shaped. Insulation is PVC; Mechanical protection: Galvanized steel wire/strips/double helical steel tape; aluminium wire amounting for single core cable; Inner and outer sheath – PVC black/grey or as per requirement.



Contact:

Empire Cable Industries (P) Ltd
Plot No: 115, Phase-II
Badli Industrial Area, Delhi 110 042
☎ 011 – 2387 4632 • Fax: 011 – 2386 1610
E-mail: empirecables@yahoo.co.in

Vertical Form Fill and Seal Machine, Mini Collar Type

Ace Pack Machines offers Vertical Form Fill and Seal Machine, Mini Collar Type. Features: This machine can be combined with Auger dosing or Cup dosing, Packs different product. Users have to choose the dosing system according to the product; Computerised Touch Screen for easy to operate; The paper pulling by means of AC gear motor with VF drive paper pulling rollers (No belt required); Horizontal sealing by means of pneumatic cylinder or by servo motor; Separate gear motor for paper unwinding; High quality colour mark Sensing Device; Batch Printing device – Optional. Specifications – Power – Auger Dosing FFS: 4.25 kW; Power – Cup Dosing FFS: 3.5 kW; Packing Speed: 50-60 Packets per minute; Packing size; 90 mm – 240 mm; Packing Material: Laminated Films like Polyester Poly, Metalized Poly BOPP, OPP, etc.; Packing Range: 2-100 g; Air Requirement: 0.3 m³/min at 6-8 bar pressure. Applications: With Auger Dosing – Powders of Masala, Turmeric, Chilly, Coriander, Coffee, Rice, Wheat, Corn, Ragi, Vibuthi, Kumkum, Sandal, Snuff, etc. With Cup Dosing – Granules like Pulses, Tea, Whole Spices, Sugar, Rice, Wheat, Sugar Candy, Seeds, Minor Millets, etc.



Contact:

Ace Pack Machines

23 VN Industrial Estate, Bharathi Colony
Peelamedu, Coimbatore, Tamil Nadu 641 004
☎ 0422 – 434 9306 • Mob: 93632 48100, 93633 48100
E-mail: acepackmachines06@gmail.com

FRP Modular Toilets

Universal Engineers offers FRP Modular Toilets. The features are: state-of-the-art products that are of a wide range, catering to future market demands and requirements; doors allow passengers to gain access and leave the passenger train. Universal Engineers has mastered the art of manufacturing doors for passengers to have the safest experience. UE has successfully delivered turnkey projects for Train 18 (Vande Bharat Express), comprising nose cone structures, continuous windows, PVC flooring, and mini-pantry equipment. They have also successfully delivered Vista Dome coaches, where their scope involved complete car body parts, interiors, panoramic windows, a sun roof, executive rotatable chairs, PAS/PIS, CCTV, luggage racks, etc.

Contact:

Universal Engineers

72 North Phase, SIDCO Indl Est, Ambattur, Chennai 600 098
☎ 044 – 2625 2158 • E-mail: director@universalengineers.in

LED Street Light

Deccan Energy Solutions Pvt Ltd offers Solar LED Street Light System. The Company is a renowned organization engaged in trading and supplying a comprehensive range of quality-tested solar LED street lights; their expert professionals supply the entire range of solar street lights in accordance with the industry-set standards. Features: stand alone; independent; maintenance free; sensor based system; highly economical and reliable; 100% short circuit; surge and lightning protection; automatic dawn to dusk operation; very useful in lighting remote locations where there is no electricity; perfect design with very low power consumption. The company is engaged in supplying and system-integrating a wide range of solar home and street lights, lanterns, water heaters, and panels.



Contact:

Deccan Energy Solutions Pvt Ltd
8A, Veekay Manor, 28 Gopalakrishna Road
Pondy Bazaar, T Nagar, Chennai 600 017
Mob: 98406 66245, 93810 03018
E-mail: admin@deccanenergy.co.in

Test & Measurement & Control Instruments

Instrument Automation offers a range of Test and Measurement and Control Instruments such as USB Process Data Logger, Universal Process Scanner and Software, USB Temperature and Humidity Data Logger, LED Temperature and Humidity Data Logger, LCD Temperature and Humidity Data Logger, Weather Sensors and Transmitters, Solar Radiation (Pyranometer) Sensor/Transmitter, Professional Automatic Weather Station, Digital Wireless Rain Gauge, Digital Compass/Altimeter, USB Digital Microscope, Digital Light Meter, Digital Oxygen Meter, Digital Carbon Dioxide Meter, Digital Vibrations Meter, Digital Thermo-Anemometer, Digital Sound Level Meter, Digital Precision Temperature and Humidity Meter, Digital Infrared Thermometer, Digital Moisture Analyzer, 4 Channel Digital Temperature Data Logger, Digital IR Imaging Thermometer, Digital Wood Moisture Meter, Temperature and Humidity Transmitter, Jumbo Display-Process Inputs, Temperature and Humidity Transmitter, Water Proof PH Testers, Pressure Transmitter with Enclosure, Multifunction Temperature and Process Calibrator, Dew Point Transmitter, Digital Coating Thickness Gage, Air Flow Hood, etc.

Contact:

Instrument Automation

46 Moogambigai Nagar, Ganapathy
Coimbatore, Tamil Nadu 641 006
Telefax: 0422 – 2332 0149 • Mob: 98430 15968
E-mail: insttautomation@gmail.com

Gear Tooth Speed & Direction Sensor

CHERRY offers from the house of ZF-TVS two channel hall effect sensor with flange mounting. The SD74 sensor series are Hall Effect products for measuring very slow movements of ferromagnetic targets. It works with an Open Drain Output. Immersion depths from 20 mm to 60 mm are available. The sensor operates from near Zero speed up to 20 kHz sensing capability. Can be used with unregulated power supply. Typical air gap ranges of 0.3 - 2.2 mm. The sensor is IP67 and ROHS compliant. The housing material is of Glass-fibre reinforced thermoplastic having maximum torque of 10 Nm (bolt ISO 4762-M6-8.8, washer ISO 7092-6-200 HV). Typical applications include Electric Drives (stationery and mobile); Automation Systems, Conveyors, and Wind Turbines.



Contact:

V G Electric
27 Amrit Niwas, 2nd Floor
165 K M Sharma Marg, Lohar Chawl, Mumbai 400 002
☎ 022 - 4006 0293 • E-mail: sales@vgswitches.com

CCTV Cables

KEI Industries Limited offers CCTV Cables. This CCTV 3+1, 4+1 construction cable is of hybrid type with combination of Communication and Electrical conductors. The 4



power cores enable powering of the CCTV camera. This cable used for combination of communication and electrical supply to CCTV Cameras and due to its composite component nature it allows CCTV installations tidy and provides lossless out. The communication cable (RG 59 Co-Axial) is used for recording the images by the camera and to communicate with the data center. Co-axial cables are designed to transmit the complete video frequency range with minimum distortion or attenuation, making them an excellent choice for CCTV. The 4 number of wires in this CCTV cables are used for powering the cameras. KEI also offers Co-Axial Cables, Telephone Switch Board Cables, CAT 6 UTP Cables, etc.

Contact:

KEI Industries Limited
D-90 Okhla Industrial Area Phase-1, New Delhi 110 020
☎ 011 - 2681 8840 / 2681 8642 • E-mail: info@kei-ind.com

Zero Point Clamping System

Andreas Maier Workholding Technology Pvt Ltd is the subsidiary of AMF-Germany. AMF offers an extensive range of clamping products and solutions tailored to meet the diverse needs of modern manufacturing processes. AMF take pride in offering you high-quality products that deliver precision, reliability, and durability, enabling you to achieve superior results in production and maximize your operational efficiency by reduction of set-up times. Features of Zero Point Clamping System: The highly precise clamping modules with high draw-in, locking and holding forces ensure perfect clamping in the widest range of applications; Effortlessly change work pieces/fixtures on your CNC machines, reduce setup times to a fraction, and improve the overall workflow; Provides a highly reliable and repeatable clamping solution, it eliminates the need for manual adjustments and tedious setup procedures; When it comes to machining, precision is everything. Whether you're producing intricate components or large-scale parts/fixtures, this system ensures that your tolerances are met with the utmost precision; One of the standout features of the AMF Zero Point Clamping System is its compatibility with a wide range of machine tools and workholding setups. Whether you have a 3-axis or 5-axis CNC machine, horizontal or vertical machining centers, this system seamlessly integrates into your existing setup; Zero Point Clamping System is engineered with robust safety mechanisms. It ensures that work pieces are securely clamped during machining operations, minimizing the risk of accidents; Investing in the AMF Zero Point Clamping System is not just an upgrade; it's a strategic investment in your company's future. The substantial time savings, improved precision, and enhanced production capacity quickly translate into a significant return on investment.



Contact:

Andreas Maier Workholding Technology, Bangalore
116 Second Cross, NHCS Layout, Basaveshwaranagar,
Bengaluru, Karnataka 560 079
☎ 080 - 2323 8444 • Mob: 90202 66876
E-mail: christo@amf.de

Fasteners

BDN Fasteners India offers a range of Fasteners made in Taiwan. The range: Valley Fixing Fasteners, Crest Fixing Fasteners, Stitching Fasteners, Concealed Fixing Fasteners, Skylight Fixing Fasteners, etc.

Contact:

BDN Fasteners India
D-62, GF, Sector-48, Noida, Gautam Budh Nagar, U P 201 301
Mob: 9717235000 • E-mail: sale@bdnfasteners.in

Fasteners

Nexo Industries Pvt Ltd attained a place among the leading manufacturers of fasteners in the world. The Company manufactures Hot Dip Galvanized and Zinc Plated Fas-



teners. Bolts Range: Hex Bolts, High Strength Friction Grip Bolts, Flange Bolts, Cup Head Bolts, Crash Barrier, Guard Rail Bolts, Socket Head Cap Screws, Wheel Bolts, Counter Sunk, Dome Head, and Machine Screws as per customer's requirement. Cold Forging (M4 to M30), Hot Forging (M10 to M80). Grade: 4.6, 4.8, 5.8, 5.8, BSW, BSF, UNC, UNF (Gr 2) Precision 6.6, 6.8, 6.9, 8.8, 10.9, Gr 2, Gr 5, Gr 8, B7, Gr 8, B7, Gr R, S, T, U, V, A325, A490. Finish: Black, Self, Zinc Plated, Rilsan Blue, and Hot Dip Galvanized. Nuts Range: Hex Nuts, Friction Grip Nuts, Square Nuts, Flange Nuts, Nylock Nuts, Dome Nuts, Commercial Nuts, Wheel Nuts, etc. Grade: Gr 4, 5, 6, 8, 10, 12, 2H, S, T, U, V. Finish: Zinc Plated, Hot Dip Galvanized, Self, Black. Washer Range: Plain Washers, Heavy Washers, Spring Washers, High Strength Friction Grip Washers as per the requirement of customers. Finish: Zinc plated, Hot Dip Galvanized; Black, and Self.

Contact:

Nexo Industries Pvt Ltd

**Vill: Mangarh, Kohara Machhiwara Road
Kohara, Ludhiana, Punjab 141 112**

☎ 0161 – 284 663, 284 8686 • E-mail: export@nexoindia.com

Rail Rubber Pads

Chamunda Enterprise offers a wide range of Rail Rubber Pads. Features: These plates are made using superior quality rubber and plastic material, reducing the shocks of vibration from a passing train; abreast of excellent mechanical features and sustainability, these products can also be customized as per clients' specific demands; rail pads are made from a variety of both natural and synthetic elastomers to meet the precise demands of the operating environment, from high-speed track to maintenance bays; a rail pad, also called a rail rubber plate, is designed between the rail tie plate and foot of the rail, made by an elastic polyurethane mat, that is interposed between steel rails and tie sleepers to protect the sleeper top from wearing and impacting. The company manufactures, trade, and export of a wide array of railway hand planar locks, railway vertical rope wheels, railway lifting barrier gates, etc.

Contact:

Chamunda Enterprise

**44 Rajen Seth Lane, Belur, Howrah, West Bengal 711 202
Mob: 96744 37382**

Austenitic Stainless Steel Fasteners

Deepak Fasteners Limited is the Largest Industrial Fasteners Manufacturer in India and the worldwide owner of the Unbrako brand. The Company is providing high quality products and delivery at the best possible prices.

Unbrako stainless steel fasteners are made from austenitic stainless steel and are ideal for corrosive, magnetic, hygienic,



cryogenic or elevated temperature environments. These fasteners offer excellent resistance to rust and corrosion from acids, organic substances, salt solutions and atmospheres. Superior properties include retention of a high percentage of tensile strength and good creep resistance up to 800°F, without scaling or oxidation. Standard processing of Unbrako fasteners includes a passivation treatment which neutralizes surface contamination. Unbrako SS304 fasteners are the most widely used. They are virtually immune to foodstuffs, sterilizing solutions, most organic chemicals and dyestuffs, and a wide variety of inorganic chemicals. They are thus useful in the food and beverage, pharmaceutical and electronic chip industries, as they maintain product purity, with the minimum contamination.

Contact:

Deepak Fasteners Ltd

**4th Floor, First Mall, Mall Road
Ludhiana, Punjab 141 001**

☎ 0161 – 513 1111 • E-mail: unbrakosales@unbrako.com

High Quality Dry Scrubber

SMD Engineering Equipments & Systems offers High Quality Dry Scrubber. The features are: It removes harmful materials from industrial exhaust gases before they are released into the environment; the offered scrubber is commonly used in plants and is utilized in a collection of dry substances to remove acidic gases that contribute to acid rain. The system sprays a collection of dry reagents



into an exhaust stream; its features include: operator friendly control; low maintenance; better performance. The company is engaged in the design, manufacture, export, trade, and import of an exclusive range of painting booths, paint shop plants, powder coating plants, and pollution control equipment.

Contact:

SMD Engineering Equipments & Systems

**No: 2, Varriyar Street, Vivekananda Nagar
Avadi, Chennai 600 054**

**☎ 044 – 2903 6705 • Mob: 95511 50504, 98844 82469
E-mail: smdequipments@gmail.com**

Flow, Level, Pressure & Temperature Sensors

Vsan Electricals And Sensors is a manufacturer and Exporter of Water and Fuel Measurements, Energy Auditing for flow, level measurements, Industry 4.0 and IoT solutions. Their products range includes: Diesel, Oil, and Fuel, Flow meters; Compressed Air Flow Meters; Level Transmitters, Level Switches, Solid Level Measurement, etc. The Company's specializa-

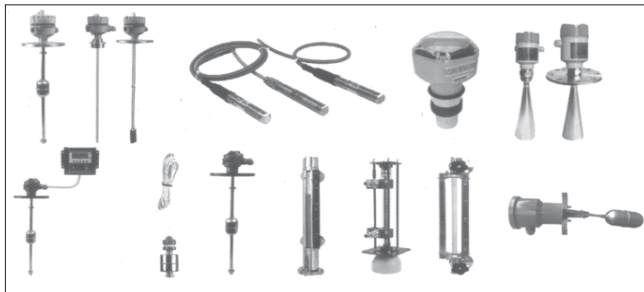

tion is: 100% Quality Assurance; 24 x 7 Tech Support; FCRI/ NABL Accredited; PESO/CCOE Products, etc.

Contact:

Vsan Electricals And Sensors
No: 10, Rajarajan Nagar Extension
Krishna Industrial Estate, Vanagaram, Chennai 600 095
Mob: 97514 75618 / 99620 98274
E-mail: vsansensors@gmail.com

Cable Armour Wire & Strips

H D Wire supplies Cable Armour Wire and Strips. Cable Armour wire, as name suggests is used in Armouring of cables made from Copper and Aluminium. The Steel wire protects the cable strands made from Copper and Aluminium, which are good conductors but are soft. Steel Armour Wire protects them from damage and also acts as an earthing wire in case of any damage to the cable. The cable Armour wires are round or flat with curvature. These wires are having lower resistivity are with medium zinc coating. Specification of Cable Armour Wire – Dia: 0.90 mm to 4.00 mm; Zinc coating: BS/ ISI/Commercial; Tensile Range: 300 to 500 Mpa; Coil Weight: 40 to 350 kg; Standard: IS 3975: 1999 / as per customer specification. Applications: for armouring various types of power cables.



Contact:

HD Wire (P) Ltd
17-20 Sector E, Industrial Area, Sanwer Road
Indore, Madhya Pradesh 452 015
☎ 0831 – 421 1199, 421 1124 • E-mail: info@hdwires.com

Cyclone Scrubbers

Teral-Aerotech Fans Pvt Ltd offers a wide range of Cyclone Scrubbers. The features are: a cyclone scrubber is a method of removing particulates from an air, gas, or liquid stream, without the use of a filter through vortex separation. When removing particulate matter from liquid, a hydrocyclone is used; while from gas, a gas cyclone is used. Rotational effects and gravity are used to separate mixtures of solids and fluids; the method can also be used to separate fine droplets of liquid from a gaseous stream; larger (denser) particles in the rotating stream have too much inertia to follow the tight curve of the stream, and thus strike the outside wall, then fall to the bottom of the cyclone where they can be removed. In a conical system, as the rotating flow moves towards the narrow end of the cyclone, the rotational radius of the stream is reduced, thus separating smaller and smaller particles; and the cyclone geometry, together with the volumetric flow rate, defines the cut point of the cyclone. The company has a range of air handling equipments, air handling fans, etc.



Contact:

Teral-Aerotech Fans Pvt Ltd
Plot No: 188-89, Ecotech Extensions-1, Kasana
Near Asian Paint, Greater Noida, Uttar Pradesh 201 301
Mob: 98101 62210, 99993 30086
E-mail: sales@teral-aerotech.com

Stationary Wet Scrubbers

Neos Air Filtration Private Limited offers Wet Scrubbers. The features are: The wet scrubber, NAS, is designed for such applications where a mechanical filter cannot be used; eg., in the filtering of aluminum dust, organic dust, explosive fumes, etc.; the design enables separation through multiphase filtration, including a generated water vortex. The filtered air can be returned into the production area; its features include: modular design; minimal footprint; low water consumption; all water contact parts are in SS304 to avoid corrosion; automatic water level control and filling; its optional features: mobile on wheels; custom colour options. The company is a manufacturer and supplier of mobile dust extractors, fume extractors, oil mist separators, downdraft tables, etc.

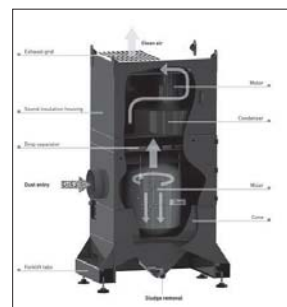

Contact:

Neos Air Filtration Private Limited
58-D, 8th Cross Street, Sidco Industrial Estate (NP)
Ambattur, Chennai 600 098
☎ 044 – 4210 4916 • Mob: 91766 01255, 97909 25588
E-mail: info@naf.co.in

Dust Collector - Dedusting System

Prakar Industries offers Dust Collector - Dedusting System. The features are: cartridge dust collectors are next generation bag filter type dust collectors using pleated cartridge filters for effectively capturing finer dusts instead of filter bags; these cartridge type dust collectors have many advantages over traditional bag collectors, like a large filter area packed in smaller overall sizes, which reduces the overall size of dust collectors for the same capacity, which saves a lot in structural casing cost and expensive factory floor space; a high filter area to overall dimension ratio means a smaller number of cartridges will be required and saves a lot of productivity time during filter change-out; the collection efficiency of well-designed cartridge filter dust collectors are up to 99.9% in collecting submicron sized particles as small as 0.3 microns. Parkar is a manufacturer of industrial blowers, dust collectors, heat exchangers, bio mass fuel fired steam boilers, coil type non IBR boilers, etc.



Contact:

Prakar Industries
Plot No: 4226, Phase IV, Vatva GIDC
Ahmedabad, Gujarat 382 445
Mob: 80007 01260, 99784 41167
E-mail: info@prakarindustries.com

Pipe Fittings

Gujarat Infrapipes Ltd supplies Pipe Fittings. The features are: these are high quality elbows, tees, reducers, and caps. The Company is capable of catering to 12000 MT of products annually, almost in all ferrous and non-ferrous material grades; these fittings are mostly in stainless steel, alloy steel, carbon steel, and duplex and super duplex stainless steel. Special products are made in seamless and welded constructions for which the Company is having distinctive facilities of hot forming, cold forming, and conventional manufacturing. The company is the largest manufacturer of pipe fittings and piping spools. GIPL has been catering to key infrastructural sectors like oil and gas, refineries and petrochemicals, power and energy, steel and ship-building, fertilizers, etc., for over 25 years.



Contact:

Gujarat Infrapipes Ltd
Survey No: 53/A, Nareshwar Road, Manglej
Vadodara, Gujarat 391 210
Mob: 99798 53166, 96876 39018
E-mail: bcr@gujaratinfra.com

Pneumatic Straight Grinder

PFERD offers pneumatic straight grinder PGAS 1/750. Its features are: the drive is equipped with a collet tool mounting for mounted tools; its advantages include: Ideal for the recommended mounted tools thanks to the collet mount-



ing; no dust turbulence on the workpiece side; removing the spindle sleeve enables narrower and harder-to-reach areas to be accessed more easily; the high rotational speed affords the drive a high cutting speed for tungsten carbide burrs and grinding points. The drive with a ring throttle can be used for continuous use. Easy guidance thanks to the slim, lightweight design. The company engaged in the development, production, support, and distribution of tool solutions on jobs for surfaces and material cutting.

Contact:

PFERD
326 B-Block, AECS Layout, Brookefield
Bengaluru, Karnataka 560 037
☎ 080 - 4218 7117 • Mob: 98806 65415, 97414 81117
E-mail: sales@swit.in

Power Hydraulic Machine Vice

B R Precisions offers Power Hydraulic Machine Vice. The features are: this type of power hydraulic vice is suitable for horizontal and vertical combined heavy cutting for CNC machining center VMC and HMC angle fixed-type spherical segment ball can produce the force for angle locking,

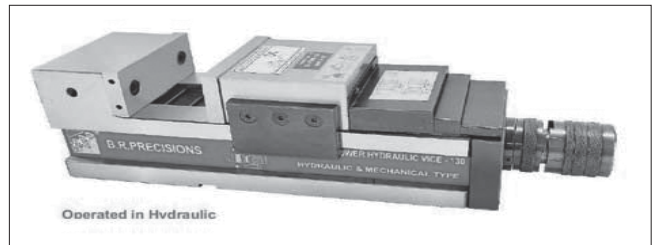

which can make the vice plate floating upward and avoid slanting of the workpiece; powerful material cast iron with high absorption and strong anti-tension, which can keep long durability for absorption; and strong rigidity with high precision tenon slot grounded, made out of high tensile casting machined and surface ground to ensure maximum accuracy. Jaw plates are made out of tool steel, hardened, and have a ground inbuilt hydraulic booster system for maximum clamping force with minimum pressure. The company, established in 1995, is an ISO 9001-2000 certified company. It manufactures and supplies precision machine vices like manual and hydraulic types, universal dividing heads, and precision straight edges.

Contact:

B R Precisions
#19, TVS Cross, Peenya Industrial Estate
1st Stage Peenya, Bengaluru, Karnataka 560 058
Mob: 98452 08854, 94496 48171
E-mail: brvices@rediffmail.com

Air Blower

Blowtech Engineers Pvt Ltd offers wide range of Hot Air Blowers. The features are: the range of hot air blowers is fabricated using high grade raw materials and components. These products are widely used for silicone and platinum coatings in different industries; some of the features of these hot air blowers are as follows: tough construction; durable standards; user-friendly operations; compactly built and easy to integrate into any industrial processes, these hot air blowers are procured from some of the most dependable vendors in the domain; and they are one of the most trusted suppliers and distributors of the hot air blowers. This range of hot air blowers consists of the AH 302 master flow hot air blower, the AH 502 master flow hot air blower, and the AH 752 master flow hot air blower.



Contact:

Blowtech Engineers Pvt Ltd

Unit No: 12, 13 & 14, Classic Ind Estate, Bhiwandi Road, Near Jain Temple, Vasai East, Kaman, Maharashtra 401 208

Mob: 90761 09010 / 90761 09020

E-mail: blowtech18@gmail.com

Disinfectant Concentrate, Multipurpose

Alpha Products offers a wide range of Multipurpose Disinfectant Concentrate. Features are: it is a dual-action cleaning and disinfection deodorizer; water-soluble; biodegradable and eco-friendly; aldehyde-free; effective on all porous and non-porous surfaces; non-hazardous, non-staining, nontoxic, and non-corrosive; and the product is known for being a one step disinfectant cleaner; it can be used to disinfect all objects and surfaces in health care, food and dairy, malls, airports, washrooms, sinks, and bathrooms; spraying in the air removes odour, and it disinfects the environment. The company is a manufacturer and supplier of a wide range of housekeeping, kitchen, and laundry products. Their product range comprises bathroom cleaners, hard surface cleaners, glass cleaners, furniture maintainer and polishing liquids, stainless steel polish, cleaners, etc.

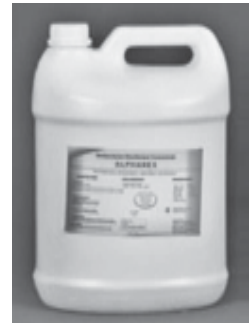

Contact:

Alpha Products

Unit No: 33-34, Sheetal Supreme Industrial Estate Dhuri Complex 2, Sativali, Vasai (E)

Palghar, Maharashtra 401 208

☎ 022 – 264 4564 • Mob: 99217 00210

E-mail: info@alphaproducts.net.in

Subscription Order Form

To,
The Circulation Manager
Product News Publication
104, Sudama Yash, Nr. Ramkrishna Hotel
Kelkar Cross Road, Ram Nagar, Dombivli (E), Thane 421 201

Dear Sir,

I / We would like to subscribe **Industrial Products Source**.

Please commence my/our subscription with the _____ (Month & Year) Issue. I / We enclose the payment of Rs. _____

Name _____

Address _____

_____ Pin code _____

Telephone _____ Mobile No. _____

Date: _____ Signature _____

1-Year (12 issues) ₹ 300/-

2-Year (24 issues) ₹ 550/-

3-Year (36 issues) ₹ 750/-

Subscribers who wish to receive magazine through courier, will be charged extra

in favour of **PRODUCT NEWS PUBLICATION**,

by "A/c. Payee" Draft / Cheque No. _____

Dated _____ of Bank _____

Our Bank details for NEFT payment Transfer:

Name of the company: **PRODUCT NEWS PUBLICATION**

Name of our bankers: IDBI BANK, Dombivli (East Branch)

Thane Dt.

A/C NO: 118102 00000 6569

Nature of Account: Current

IFS Code: IBKL0000455

Industrial Products Source

Visit us at: www.ips.co.in / www.industrialproductssource.com

Robotic Deburring of Cylinder Head / Block – RMD Series

Grind Master Machines Pvt Ltd offers Robotic Deburring of Cylinder Head / Block – RMD Series. The features are: This machine is used for deburring faces, oil hole galleries, pockets, etc.; the deburring process ensures the removal of even minute secondary burrs from the component, resulting in a smooth and extended product life; the following are the main features of this machine: ultra user-friendly nanofinish control system; automatic conveyor load/unload; uniform and consistent deburring. The company specialises in special purpose machines for metal finishing, deburring, microfinishing, and robotic automation and is a total solution provider for surface finishing requirements.



Contact:

Grind Master Machines Pvt Ltd
B-10/ B-11/ B-14, MIDC, Near Railway Station
Aurangabad, Maharashtra 431 005
Mob: 90499 48833
E-mail: sales@grindmaster.co.in

3D Measurement Software for CNC Machining Centres

Blum-Novotest Measuring & Testing Technology Pvt Ltd offers 3D Measurement Software for CNC Machining Centres. The features are: user-friendly software for rapid quality control of contour measurement and standard geometric elements in CNC machining centers; its features including: Complex measurements in the machining clamping; orientation of probe or workpiece at will, measurement of relief cuts or oblique borings possible; 5-axis measurement of what was machined on 5 axes; no measuring point remains unattainable; individual display of measurement values on the PC; large number of measuring points via colour bar graphs or colour points; output of measurement results in tabular form in CSV format. The company has made a name for itself in the list of top suppliers of bore gauges and radio receivers in India.



Contact:

Blum-Novotest Measuring & Testing Technology Pvt Ltd
No: 06 (Old No: 107) 2nd Floor, 1st Main Road
Widia Layout, Attiguppe, Bengaluru, Karnataka 560 040
☎ 080 – 2318 5468 • Mob: 90750 04435
E-mail: info@blumnovotestindia.com

Deep Filter Cartridge

Pure Aqua Engineers offers Deep Filter Cartridge. The features are: this is a kind of deep filter cartridge, which is made of the textile fabric string preciously winding onto the multi hole axles according to the specific technology; with the honey-comb con structure of loose outside and tight inside, it mainly filters the low viscosity and impurity matters, such as suspension, particles, rust, and other impurities; and this kind of filter cartridge is used in filtering tap water, industrial water, living water, electroplate liquid, chemical liquid, oil, paint, and so on. The company is instrumental in manufacturing, supplying, trading, and importing a broad assortment of superior quality filter cartridges, bag filter assemblies, fab media, distribution systems, PP molded filter housings, filter bags, plastic filter nozzles, and multi port valves.



Contact:

Pure Aqua Engineers
94 First Floor, Rameshwar Industrial Estate, Kenal Road
Odhav, Bapunagar, Ahmedabad, Gujarat 380 024
Mob: 95860 23661 • E-mail: viral@pureaquaengineers.com

Distribution System

Pure Aqua Engineers offers Distribution Systems or all types of Filters. The features are: softeners and demineralization plants, which are used for uniform collection of the feed water owing to their larger area of collection; these distribution systems are constructed using high-grade material and are fitted with world class components to make sure that they work efficiently at the client's end; these power distribution systems yield higher efficiency and have a longer life; these distribution systems are easy to assemble and install; integrated with perforated pipe laterals that allow easy channeling of water flow; available in varied specifications; these systems allow uniform distribution of the backwash water and air. The company is instrumental in manufacturing, supplying, trading, and importing a broad assortment of superior quality filter cartridges, bag filter assemblies, fab media, distribution systems, PP molded filter housings, filter bags, plastic filter nozzles, and multi port valves.



Contact:

Pure Aqua Engineers
94 First Floor, Rameshwar Industrial Estate, Kenal Road
Odhav, Bapunagar, Ahmedabad, Gujarat 380 024
Mob: 95860 23661 • E-mail: viral@pureaquaengineers.com

Industrial Roboaggregates

Robo Silicon Pvt Ltd offers Industrial Roboaggregates. The features are: these roboaggregates are obtained by crushing parent rock and exhibit better bonding at the interface of aggregates with cement paste; they are crushed by a three-stage configuration consisting of a jaw crusher followed by a cone crusher and finally a vertical shaft impactor (VSI) to obtain aggregates that have cubical particle shapes and are consistent in gradation; and roboaggregates find extensive use for new infrastructure work and maintenance of existing infrastructure. Since the company's establishment in 1999 and subsequent product launch in 2001, the endeavor has been to offer the best in every aspect – be it mining, quarrying, processing, or the delivery of the products.



Contact:

Robo Silicon Pvt Ltd
402, 4th Floor, Sri Durga Towers, Road No: 10
Avenue 4, Banjara Hills, Hyderabad, Telangana 500 034
☎ 040 – 4546 7210 • E-mail: robosand@robo.co.in

Thread Turning

Vardex Tooling Private Limited offers Thread Turning. The features are: the Vardex indexable laydown thread turning insert technology was developed many years ago. Its patented designs continue to be the industry standard to this day. With over 6000 different tools; these thread turning tools offer the largest and most extensive collection of pitches and standards in different grades, IC ranges, and types of insert styles, as well as customized methods for the oil and gas industry. Its features include: precise coolant thru, designed to efficiently cool down the cutting edge; suitability for high pressure coolant (up to 70 bar); reduced cutting edge temperature for better tool life; better chip evacuation; and improved chip control and flow; external holders with coolant are fully supported by VARGUS GENius™, the most advanced tool selector and CNC program generator in the metal cutting tool industry. The company is a world-leading manufacturer of high-quality cutting, grooving, and deburring tools for the metals and plastics industries.

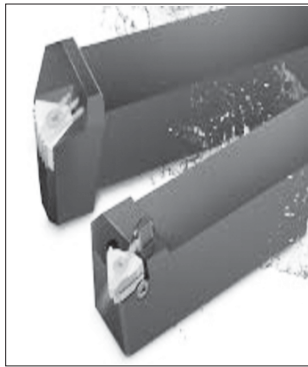

Contact:

Vardex Tooling Private Limited
S No: 185, Sukhwani Boulevard Commerz
304 Pashan-Sus Road, Near H P Petrol Pump
Pune, Maharashtra 411 021
Mob: 90115 53000 • E-mail: info@vargusindia.com

Precision Twin Machine Vice

B R Precisions offers Precision Twin Machine Vice. Features: It is capable of clamping two pieces simultaneously with one single movement of the handle, keeping the total length constant; this makes it ideal for machining series of work pieces in machining centers; the exterior clamping system towards the center makes the elevated forces in the clamp area to be compensated dynamically, thus avoiding deformations; grinding of all surfaces; possible working positions supported on the base on the side or vertically on the head; suitable for working in horizontal and vertical machining centers; squareness and parallelism accuracy at 0.02 microns. The company is an ISO 9001-2000 certified and manufactures and supplies precision machine vices like manual and hydraulic types, universal dividing heads, and precision straight edges.

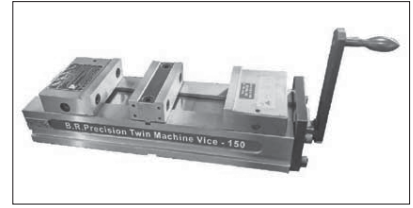

Contact:

B R Precisions
#19, TVS Cross, Peenya Industrial Estate
1st Stage Peenya, Bengaluru, Karnataka 560 058
Mob: 98452 08854, 94496 48171
E-mail: brvices@rediffmail.com

Welded Pipes and Tubes

Shalco Industries Pvt Ltd offers Welded Pipes and Tubes. The features are: welded tubes and pipes are processed using electric resistance welding (ERW) and the cold drawing method; in this process, coils are slit into custom widths to achieve the desired size; these strips are passed through a roll-forming mill, forming a tubular shape; these tubular shapes are further passed through a high resistance electric welder (ERW), where the edges of tubular shapes are welded under pressure, forming a clean and stronger bond than the parent material; this process can be achieved in a wide range of raw materials. At this stage, the tubes and pipes can be used for less demanding applications in industries such as the furniture, food, etc. The company is an ISO 9001:2008 certified and a leading manufacturer of steel and stainless steel products.

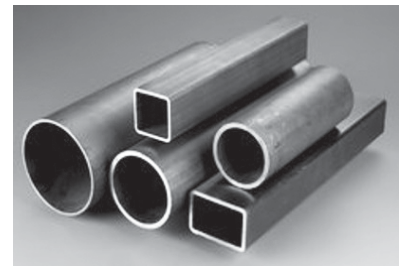

Contact:

Shalco Industries Pvt Ltd
24/2 Daya Bhai Building, 56 Kika Street
Gulal Wadi, Mumbai 400 004
☎ 022 – 6249 8200, 6249 8214
E-mail: info@shalco.in

Nickel Alloys & Duplex Stainless Steel

Suraj Metal Corporation supplies Nickel Alloys and Duplex Stainless Steel. It was developed as a product that could improve upon some of the technical weaknesses of

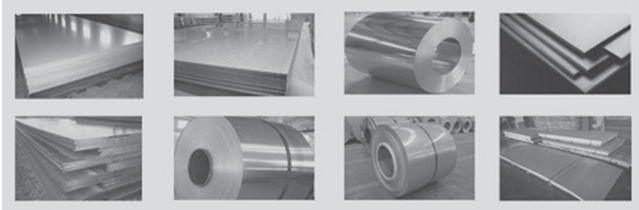

the standard austenitic and ferritic stainless steels that are available in the market; both have low strength, ferritic steels have poor low temperature toughness, and austenitic steels have a very low resistance to stress corrosion cracking; and these duplex stainless steels have a microstructure that is split roughly 50:50 between austenite and ferrite, and balancing of these phases provides the following benefits: higher strength, which is around twice that of type 304 austenitic stainless steel. The company is a leading supplier of various stainless steel and nickel alloy products.

Contact:

Suraj Metal Corporation

21, 2nd Carpenter St, Charni Road East, Cawasji Patel Tank Bhuleshwar, Mumbai 400 004

☎ 022 – 2389 5697 • Mob: 96196 24188, 83694 10192

E-mail: mishal@surajmetal.com

Balanced Weave Conveyor Belt

Bharat Wire Mesh Company offers Balanced Weave Conveyor Belt. The features are: the mesh of compound balance weave conveyor belts is very closed, so these belts are used in those applications that include carrying very small parts, such as nuts, bolts, screws, nails, etc.; its features include: a small open area; the compound weave conveyor belts have a small open area, which is suitable to convey small items; high tensile strength; durability; and a long service life. Different types of baffles can be added at both the side and center of the conveyor belt for sorting and conveying products. The company is into the manufacturing of metal/wire mesh conveyor belts (SS/GI/MS), which are used in various industries such as food processing, heat treatment, ceramics, automotive, furnaces, etc.

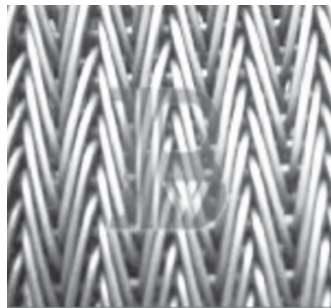

Contact:

Bharat Wire Mesh Company

D-11, Shiv Bhole Laghu Udyog

Opp: Hindustan Construction Company, Ambewadi

LBS Marg, Vikhroli (West), Mumbai 400 083

☎ 022 – 2579 4145

E-mail: sales@bharatwiremesh.com

Stainless Steel Sheets Plates and Coils

Ratnamik Metal (India) supplies Stainless Steel Sheets Plates and Coils. The features are: these plates and sheets are available in stainless steel, nickel alloy, carbon steel, alloy steel, and duplex steel; they produce sheets and plates of standard quality, high strength, corrosion resistance, and a finished product of no defect; plates and sheets are highly customized and available in different ranges as per the requirements stated by their clients; and these plates and sheets are extensively used in the industrial sector for manufacturing machines and so on. The company is built on a result oriented work culture, to fulfill customers's needs in terms of cost, quality, and delivery. By enhancing the effectiveness of people and plant equipment safely, management style has been the key to their success, as they delegate responsibility to the specific needs of every customer and have made every customer a member of their family.

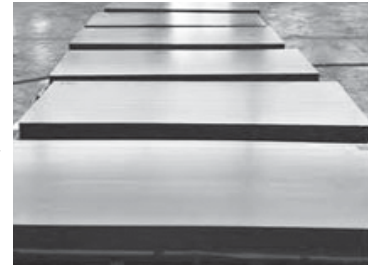

Contact:

Ratnamik Metal (India)

Office No: 8, 1st Floor, Aayesha Manzil, Building No: 81/83

4th Kumbharwada, Mumbai 400 004

☎ 022 – 2386 4009 • Mob: 98338 64009

E-mail: ratnamikmetal@yahoo.com

Stainless Steel Pipes and Tubes

Ratnamik Metal (India) offers Stainless Steel Pipes and Tubes. The features are: a sturdy range of stainless steel pipes that are capacitated to withstand temperature variations and thus are used in heat transfer process equipment like boilers, super heaters, heat exchangers, condensers, and similar applications; these stainless steel pipes can be customized depending upon their industrial usage. The company is built on a result oriented work culture, to fulfill customers's needs in terms of cost, quality, and delivery. By enhancing the effectiveness of people and plant equipment safely, management style has been the key to their success, as they delegate responsibility to the specific needs of every customer and have made every customer a member of their family.



Contact:

Ratnamik Metal (India)

Office No: 8, 1st Floor, Aayesha Manzil, Building No: 81/83

4th Kumbharwada, Mumbai 400 004

☎ 022 – 2386 4009 • Mob: 98338 64009

E-mail: ratnamikmetal@yahoo.com

Industrial PTFE Tape

Sanghvi Products offers Industrial PTFE Tape. The features are: these expanded soft packings are made from a special grade PTFE resin with a one side adhesive strip. This expanded soft packing fills all the voids in uneven or damaged surfaces, thereby giving perfect sealing; it is chemically inert and can be used with almost all chemicals. One side of the packing has an adhesive strip hence it is very easy to install; it is widely used in place of gaskets. Recommended for sealing flanges, housings of pumps, compressors, gearboxes, manholes, heat exchangers, reactors, agitators, mixers, tank lids, and many other such applications. The company is an UL certified, and a market leader, largest producer of thread sealant tapes made of PTFE and non-asbestos based varieties of packing. The company is built on the corporate philosophy of Sanghvi Group, "Excellence through Experience," and has almost three decades of experience in the industry.



Contact:

Sanghvi Products

182/3 Opp: Balahanuman Fabrics, B/s: Anand Industrial Est
Ranipur Gam, Narol, Ahmedabad, Gujarat 382 405
Mob: 99130 63634 • E-mail: sales@sanghviproducts.com

PTFE Graphite Packing

Sanghvi Products offers PTFE Graphite Packing. The features are: PTFE blended with graphite and lubricated with an inert high temperature lubricant; this packing is suitable for high-speed rotary applications; it can be used in contact with most media, including the most aggressive; it is also suitable for oxygen, paints, lacquers, varnishes; this packing is used in chemicals, petrochemicals, paper and pulp industries, textile industries, power plants, etc. The company is an UL certified, and a market leader, and the largest producer of thread sealant tapes made of PTFE and non-asbestos based varieties of packing. The company is built on the corporate philosophy of Sanghvi Group, "Excellence through Experience," and has almost three decades of experience in the industry. It has been a consistent quality product manufacturer.



Contact:

Sanghvi Products

182/3 Opp: Balahanuman Fabrics, B/s: Anand Industrial Est
Ranipur Gam, Narol, Ahmedabad, Gujarat 382 405
Mob: 99130 63634
E-mail: sales@sanghviproducts.com

Industrial Cotton Rope

Shankar Dori Udyog offers a wide range of an Industrial Cotton Ropes. The features are: the cotton dori can be used in garment industries, sports industries, textile industries, and fashion accessories. However, the cotton ropes

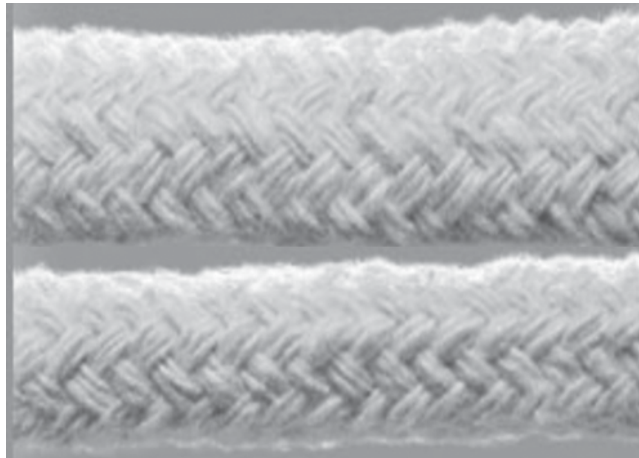

are also used in decoration as well as for hanging purposes; they can make available cotton ropes in various sizes and colors as per buyer requirements. Its features include: cotton rope is good for skin, and hypoallergenic; construction: 16 Standard; colour: natural grey; packing: 10-20 kg bundle. Shankar Dori Udyog is the manufacturer and exporter of a wide range of products, including cotton twisted rope, cotton braided rope, polyester twine, polyester braided rope, polypropylene twine, polypropylene braided rope, nylon braided rope, climbing rope, etc.

Contact:

Shankar Dori Udyog

08 Sports Complex Enclave, Delhi Road
Mohkam Pur, Meerut, Uttar Pradesh 250 002
Mob: 94122 01883, 99971 07303
E-mail: info@shankardori.com

Industrial Quality Alloys

Shalco Industries Pvt Ltd, an ISO 9001:2008 certified Company offers Industrial Quality Alloys. The Company has maintained its goodwill with unmatched quality and unsurpassed commitment towards the needs and requirements of its clients. It manufactures stainless steel seamless and welded pipes and tubes; nickel alloys, also known as super alloys, are those metals that contain more than 30% nickel. It is a hard and ductile metal of a silver-white color. It has high corrosion resistance and is suitable for both high and low temperature applications.



Contact:

Shalco Industries Pvt Ltd

24/2 Daya Bhai Building, 56 Kika Street
Gulal Wadi, Mumbai 400 004
☎ 022 - 6249 8200, 6249 8214
E-mail: info@shalco.in

Strip Heaters

Sri Balaji Heat Engineers offers Strip Heaters. Their features are: Strip heaters are made up of high quality Nichrome ribbon wire that is insulated in fluted refractory. A specially selected mica strip provides the heat distribution for maximum heater life; mica of proper thickness is used to insulate the windings, providing excellent thermal conductivity and dielectric strength; and the elements are encased in specially treated rust-resistant steel or stainless steel casing to provide physical strength and good thermal conductivity for sheath temperatures up to 3000°C Type 304 stainless steel sheath provides resistance to high temperatures and corrosion. The company makes all kinds of industrial heaters, like air heaters, long-life finned U-shaped air heaters, strip-finned heaters, cartridge brass heaters, etc.

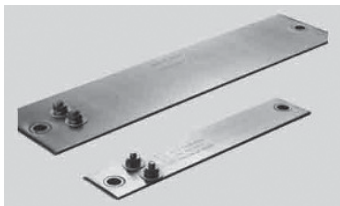

Contact:

Sri Balaji Heat Engineers
Phase V, Rami Reddy Nagar, Jeedimetla
Hyderabad, Telangana 500 055
Mob: 98486 16195 • E-mail: sribalajiheatengineers.com

Spring Washer

Khanwalkar Industries was established in the year 1975. Khanwalkar industries, an ISO 9001:2015 certified company manufacturing CARBON brand Spring Washer in carbon steel (EN-42B), and in stainless steel (SS-304). These are manufactured on automatic machines within close tolerances and under strict quality control that are applicable to production process. This ensures that components conform to consistent quality and high standards. The company supplies its product CARBON Spring Washers conforming to various Standards like ISS, BSS, DIN, ASA, JIS and also in Stainless Steel (SS-304, SS-316 and SS-202) all over India. Washers conforming to special sizes and Combi sizes are also available. Washers are manufactured in ID size 2.5 mm to 50 mm in natural black and in electroplated coating with blue, golden green finish and with trivalent coating. Besides the spring washers, the Company has diversified into manufacturing of spring washers machines.



Contact:.

Khanwalkar Industries
36-C, Sector B, Sanwer Road, Industrial Area
Indore, Madhya Pradesh 452 015
☎ 0731 – 272 1527, 404 6226 • Mob: 99935 55087
E-mail: khanwalkar08@gmail.com

Statement about the ownership and other particulars about **Industrial Products Source** as required to be published in the first issue of every year after the last day of February, under Rule 8 of the Registrar of the Newspapers, Ministry of Information and Broadcasting.

Form IV

1. Place of Publication : Dombivli
2. Periodicity : Monthly
3. Printer's Name : Mohanan. N.
Nationality : Indian
Address : A/10 Jayashree Laxmi Puja, Plot 78/82
Ramachandra Nagar, Dombivli (E), Thane 421201
4. Publisher's Name : Mohanan. N.
Nationality : Indian
Address : A/10 Jayashree Laxmi Puja, Plot 78/82
Ramachandra Nagar, Dombivli (E), Thane 421201
5. Editor's Name : Mohanan. N.
Nationality : Indian
Address : A/10 Jayashree Laxmi Puja, Plot 78/82
Ramachandra Nagar, Dombivli (E), Thane 421201
6. Name and address of the individuals who own the magazine and partners or shareholders owning more than 1 per cent of the total capital : Owned by Product News Publication
7. Partners
 - i) Mohanan. N. : A/10 Jayashree Laxmi Puja, Plot 78/82
Ramachandra Nagar, Dombivli (E), Thane 421201
 - ii) Jayashree Mohanan : A/10 Jayashree Laxmi Puja, Plot 78/82
Ramachandra Nagar, Dombivli (E), Thane 421201
 - iii) Madanmohan Nair : B-201, Smit CHS, P&T Colony
Dombivli (E), Thane 421 201
 - iv) Panchalikutty M Nair : B-201, Smit CHS, P&T Colony
Dombivli (E), Thane 421 201

I, Mohanan N, hereby declare that the particulars given above are true to the best of my knowledge and belief.

Dated: 1st March 2024

Mohanan. N.
Signature of the Publisher

Electro-Pneumatic Brake System for EMU

Escorts Kubota Limited offers Electro-Pneumatic Brake System for EMU. Their features are: one of the largest railway networks in the world with a super dense crush load on their EMU and MEMU stock running on a suburban network across various cities in India; Escorts have been manufacturing electro-pneumatic brake systems for more than three decades; Escorts EP brake system has two distinct modes of operation; its features include: rapid application and release of brakes; graduated application and release; auto control for fail-safe operation in electrical failure. The company is among India's leading engineering conglomerates operating in the high growth sectors of agri-machinery, construction and material handling equipment, railway equipment, and auto components.

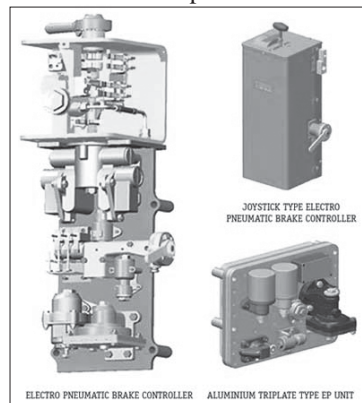

Contact:

Escorts Kubota Limited
15/5 Mathura Road, Faridabad, Haryana 121 003
☎ 0129 – 257 6000, 223 2148
E-mail: ekl_ex.railheadoffice@escortskubota.com

Industrial Products Source

A Magazine for Indian Industries since 2004

SPECIAL SECTION SCHEDULE - April 2024 to March 2025

April	2024	Pumps & Valves, Pneumatics & Hydraulics, Chemical & Petrochemicals, Process Plant & Machinery
May	2024	INTEC 2024 Exhibition + Focus: Machine Tools & Automobile Accessories
June	2024	Foundry Equipment, Casting, Forging & Shot Blasting, Boilers & Furnaces
July	2024	Industrial Automation, Instrumentation, Testing & Measuring Instrument
August	2024	Gears & Bearings, Motors & Drives, Clutches & Brakes, Oils & Lubricants
September	2024	Pumps, Valves, Tubes & Pipe Fittings
October	2024	Material Handling & Storage Equipment
November	2024	Electrical & Electronics, Solar, Wind & Alternative Energy
December	2024	21 st Annual Issue
January	2025	IMTEX 2025 Exhibition + Focus: Machine Tools & Auto Components
February	2025	Chemical, Pharma, Bio-Tech & Food Processing Packaging, Pollution Control Equipment
March	2025	Cables, Wires, Connectors, Control Panels Transformers Switchgears & Welding Equipment



Area of Circulation (Industry wise)

- Agriculture
- Air Condition
- Airlines & Aerospace Industries
- Atomic Sector
- Automation
- Automobile
- Bio-Tech & Pharmaceuticals
- Boilers
- Banking Sector
- Cement
- Ceramics
- Chemical Plants
- Construction Machinery & Equipment
- Defence
- Electrical & Electronics
- Exporters
- Fasteners
- Fertilizer
- Food & Beverage
- Foundry & Forgings
- Heat Exchangers & Cooling Towers
- Heavy Engineering
- Hydraulics & Pneumatics
- Industrial Safety & Security
- Libraries
- Machine Tools
- Material Handling
- Oils & Refineries
- Paints
- Paper & Pulp
- Petrochemicals
- Plastic & Rubber
- Pollution Control Boards
- Printing & Packaging
- Project Consultants
- Pumps & Valves
- Railways
- Research Institutions
- Steel
- Sugar / Tea
- Testing Laboratories
- Textiles
- Universities
- Welding

Advertisement Tariff

Size	4-Color	Black & White
Full Page (17.5 [W] x 25 [H] cm)	₹ 21,000/-	₹ 14,000/-
Half Page (H-17.5 [W] x 12 [H] cm) (V-8.5 [W] x 25 [H] cm)	₹ 12,800/-	₹ 8,500/-
Quarter Page (8.5 [W] x 12 [H] cm)	₹ 7,200/-	₹ 4,800/-
Double Spread (35 [W] x 25 [H] cm)	₹ 42,000/-	₹ 28,000/-
Cover Pages		4 - Color
Front Cover-Half Page (H)	₹ 24,000/-	
Front Cover-Quarter Page	₹ 15,000/-	
Front Cover-Strip (H) (17.5 [W] x 6 [H] cm)	₹ 15,000/-	
Front Inside Cover	₹ 27,000/-	
Back Inside Cover	₹ 27,000/-	
Back Cover	₹ 32,400/-	
Front Gate Fold	₹ 54,000/-	

Home Page	3-Months	6-Months
Small Banner (100 x 100 pixels)	₹ 6,000/-	₹ 10,000/-
Large Banner (240 x 100 pixels)	₹ 8,000/-	₹ 14,000/-
□ Inclusive of Design & Hosting - 12 kb maximum □ If the advertiser wishes to change the design or any updating in the banner will be charged extra		

Subscription Charges	
1-Year (12 Issues)	₹ 300/-
2-Year (24 Issues)	₹ 550/-
3-Year (36 Issues)	₹ 750/-
Outstation payment should be at par cheque/DD drawn in favour of "Product News Publication" only	

Trim Size: 28 [H] x 21 [W] cms; Bleed Size: 28.6 [H] x 21.6 [W] cms Material Requirement: CorelDraw or PDF Files



Editorial, Circulation & Marketing Office

Product News Publication

104, Sudama Yash, Nr: Ramkrishna Hotel, Kelkar Cross Road, Ram Nagar, Dombivli (E), Thane 421 201
 Mobile: 98206 70855 / 98208 38998 • E-mail: ipsmaginfo@gmail.com / ipsmag@yahoo.com

Visit: www.ips.co.in / www.industrialproductssource.com to view our e-magazine

Depaneling Machine

Schunk offers a wide range of Depaneling Machines. Depaneling machine for separating circuit boards Schunk Electronic Solutions is setting standards in the field of depaneling technology; offers solutions for the entire spectrum of the depaneling operation, from product selection, workpiece holder solutions, and optimization of milling parameters to commissioning; this product range focuses on modern processes in electronic assembly group production.

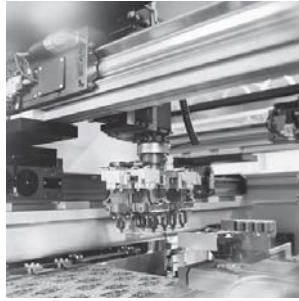

Their systems and devices meet the most demanding requirements resulting from increasing miniaturization, the use of highly sensitive components, and the rising quality demands for printed circuit boards. The depaneling machines are high-performance machines. The company is engaged in the distribution and supply of industrial automation systems, automation work holding, tool holding, etc.

Contact:

Schunk Intec India Pvt Ltd

**No: 80-A3 & 80C, C-1, Yeshwanthpur Industrial Area
Bengaluru, Karnataka 560 022**

☎ 080 – 4053 8999

E-mail: info@in.schunk.com

Humidity & Temperature Sensors

Jupiter Electronics offers a range of Humidity and Temperature Sensors like Low Cost Humidity and Temperature Transmitters, Humidity and Temperature Probes, Hygro-Palm Series, Transmitters for BMS and HVAC applications, High Accuracy Humidity and Temperature Transmitters, Metrological Probes, Thermo Hygrometer and T/RH Sensor with RS-485, Industrial Humidity and Temperature Transmitters, Data Loggers, Humidity and Temperature Calibrators, etc. Applications: HVAC and Building Automation Systems, Laboratories, Incubators, Weather Monitoring, Health Inspection Agencies, Warehouse Mapping, Paper, Textile and Pharmaceuticals Industries. The Company also supplies Velocity/Flow/Dew Point Moisture in Oil Transmitters, Differential Pressure/Air Velocity/Flow Transmitters; Differential Pressure Gauges and Transmitters/Switches, CO₂ Transmitters; Pressure Transmitters/Pressure Switches/Gauges/Data Loggers etc.



Contact:

Jupiter Electronics

A-401 & G-414-416, Kailash Industrial Complex

B/h: Godrej Colony, Parksite, Vikhroli West), Mumbai 400 079

☎ 022 – 6755 1606, 2517 0795

E-mail: sales@jupiteredlectronics.co.in

Low Harmonics Regenerative Matrix Converter

Yaskawa India Pvt Ltd offers U1000 Low harmonics Regenerative Matrix Converter. It is built on Yaskawa matrix technology, is a highly efficient AC drive. It excels in energy savings with full power regeneration and maintains sinusoidal input currents, reducing strain on grid components. Its compact design makes it the top choice for energy-efficient drive solutions, whether power regeneration is required or not. Functional Safety Built-in: U1000 has integrated SIL3 and PLe Safe Torque Off (STO) performance. The matrix converter is TUV tested and certified to ISO/EN 13849-1 Cat.3 PLe and IEC/EN61508 SIL3 (two safety inputs and one EDM output. Simple wiring; Less components; Higher reliability; Space saving. Power Regeneration: The U1000, a compact AC to AC drive, eliminates the need for a DC bus, making it more efficient by avoiding braking resistors and enabling regenerative energy reuse, reducing overall energy costs and panel cooling needs. Saves energy; Less heat is generated, reduces the need of ventilation; No braking resistor – greatly decreases the risk of fire; Less maintenance; Less components; Compact design; Significant reduction in panel cooling requirements; Easy conversion from an existing to a new system; 100% of resistor's wasted energy saved; Designed for 10 years of maintenance-free use. Applications of U1000: Escalators, Air Conditioning, Pumps, Fans, Compressors, Medical equipment, Data Centers, Conveyors.



Contact:

YASKAWA India Pvt Ltd

**17/A, 2nd Main, Electronic City-Phase 1, Hosur Road
Bengaluru, Karnataka 560 100**

☎ 080 – 4244 1999 • E-mail: info@yaskawa.in

CNC Polygon Turning Machine, Mini Model SPM42

Electromac Automation manufactures CNC Polygon Turning Machine, Mini Model SPM42. Features: Polygon Profile: Even Number; Max Job holding: Dia 42 mm; Max across Flat: 80 mm; Minimum across Flat: 3 mm; X Axis Stroke: 100 mm; Z Axis Stroke: 100 mm; Spindle: A2-6 Built in Sleeve; Max SPN Speed: 500 rpm; Job Clamping: Collet – A42 Built in sleeve; Chucking Cylinder: Pragati – Rotary Chucking Cylinder; Control System: CNC, FANUC OITF-Plus; Total Power: 4 kW.

Contact:

Electromac Automation

**No: A17, Munusamy Industrial Complex, Munusamy Street
First Cross, Athipet, Chennai 500 058**

Mob: 98411 03190, 98849 75852

E-mail: electromacautomation@gmail.com

PhotonX i-Cut

Laser Technologies Private Limited offers PhotonX – i-Cut. Photon X Series laser cutters are complete solution for processing large format materials. Whether for product display production and shop fitting, architectural model making, membrane keyboard production, print service providers, advertising technology, finishing of advertising or technical textiles and furniture construction, the



laser systems are developed for 24x7 operation and let you work quickly, productively and reliably. No matter whether crystal-clear edges without post processing or finest details and radii in acrylic, sealed cut edges without fraying in textiles or the chip-free processing of various plastics, wood or wood composites – productivity will increase simply by reducing process steps such as flame polishing, material clamping or seaming. By additionally saving set-up costs, cleaning time and tool procurement, you still have time and money to accept new orders and drive your company growth. Technical Parameters – Laser Power: 80 W/100 W/130 W/150 W; Processing Area: 900 x 600 / 1300 x 900 / 1400 x 1000 / 1600 x 1000 / 1800 x 1000 x 2500 x 1300 mm; Max Running Speed: 400 mm/sec; Power Supply: AC 220 V ±10% 50 Hz; X/Y Location Precision: 0.1 mm; X/Y Repeated Location Precision: ±0.1 mm; Machine Gross Power: £ 1250 W; Running Temperature: 0°C-40°C; Blowing System: Lower Blowing System (Upper Blowing System is available); Formats: CDR, BMP, PLT, JPEG, DXF, DST, AI; Applied Materials: Acrylic, LGP, MDF, Plywood, Advertisement and Decoration.

Contact:

Laser Technologies Private Limited
Plot NO: PAP/R/406, Near CG Motors, Rabale MIDC
Rabale, Navi Mumbai 400 701
☎ 022 – 4131 0099 • Mob: 70458 85802
E-mail: info@lasertechnologies.co.in

Rubber Conveyor Belts

Sakthi Conveyors is a dealer, distributor and exporter of Rubber Conveyor Belt of all grades for material handling. Sakthi guarantees a most reliable and cost-efficient solutions to its clients. Industries served are: Stone Quarries; Paper Mills; Steel, Cement, Packing, Chemical, Coir, and Food Industries; Metal Crusher; Tea Estates; Power Plants; Special Purpose Industries/Machines; Coal Mining; and Ports. The Company's products range includes: PU-Panels, V-Belts, Idler with Rollers, Industrial Floor Mat, etc.

Contact:

Sakthi Conveyors
345/1 Podanur Main Road, Podanur
Coimbatore, Tamil Nadu 641 023
☎ 0422 – 437 1687 • Mob: 90035 55444
E-mail: conveyorbeltshop@gmail.com

Automatic Changeover-cum-Current Limiter (ACCL) M32D

Electron Combine offers ACCL, which is a fully automatic, high precision system installed in apartments, residential complexes, and commercial buildings. It has the following

functions: The ACCL allows unrestricted power on Mains. If both supplies are available, EB is given preference. When EB fails and the standby Generator is ON it transfers the load to DG and begins monitoring the load; While on DG, if the load current exceeds a pre-set limit, the output

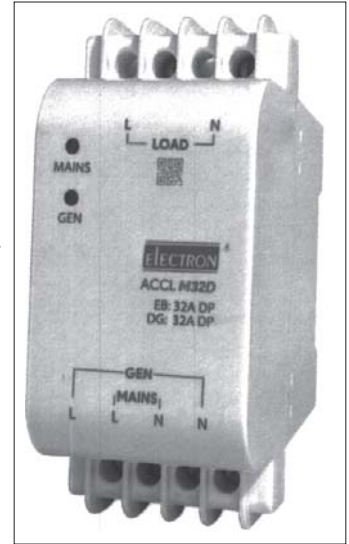

trips. Other consumers who are within limits continue enjoying uninterrupted DG power, after 8/10/12 seconds, the load is reconnected and monitored again. If the current drawn has been reduced by switching off unneeded appliances, supply continues, else, it trips again. When EB gets restored, the ACCL automatically disconnects the load from DG and transfers to EB. The M32D is a heavy-duty, all new contactor based design for single-phase lighting + power loads up to 32 A. Smallest footprint – TP MCB width (only 54 mm); DIN channel mounting. Rated Loads: 32 A (EB); 32 A (DG); Suited for: Lighting Power loads; Dimensions (W x H x D): 54 x 124 x 112 mm; Switching device: Contactor.

Contact:

Electron Combine
Y-15, Salt Lake Electronics Complex
Sector-5, Kolkata 700 091
☎ 033 – 4602 3297 • Mob: 98307 00789
E-mail: combine@electron.in

Material Handling Equipment

Nilkamal Limited offers a range of material handling equipment such as Hand Pallet Truck, Manual Stacker, Semi-electrical Stacker, Aisle Master Articulated Forklift, High Level Order Picker, Magaziner Man-up VNA Equipment, Double Deep Reach Truck, Electric Reach Stacker, Electric Forklift, Battery Operated Pallet Truck, Scissor Lift, and Dock Leveller, High Level Order Picker, Double Deep Reach Truck, etc.



Contact:

Nilkamal Limited
Nilkamal House, Plot No: 77 & 78, Street No: 14
MIDC, Andheri (East), Mumbai 400 093
Toll Free Number: 1800 121 9115
E-mail: marketing@nilkamal.com

Power Foundation of India and Climate Policy Initiative Jointly Organize a Conference on “Distributed Renewable Energy for Sustainable Development”

Power Foundation of India organized a conference on “Distributed Renewable Energy for Sustainable Development” at The Ashok, New Delhi, on 27th February 2024. The Conference was organized in collaboration with Climate Policy Initiative.

The Conference brought together key stakeholders from the Government, Private and Public sectors, and policy think tanks. Notable participants included Shri Bhupinder Singh Bhalla, Secretary, Ministry of New and Renewable Energy, Shri S C L Das, Secretary, Ministry of Micro, Small & Medium Enterprises, Shri Gurdeep Singh, CMD, NTPC and Dr. Tripta Thakur, Director General, National Power Training Institute (NPTI).

Rural India presents very distinct challenges to those encountered in concentrated urban and industrialized clusters and is critical to India’s decarbonization efforts. Recognizing the significance of rural areas, the conference emphasized the importance of decentralized, community-driven, and localized solutions, particularly Distributed Renewable Energy (DRE) projects. The conference shed light on the critical role of DRE in India’s decarbonization efforts, identifying impediments and advocating policy actions for broader adoption.

Shri Sanjiv Nandan Sahai, Director General, Power Foundation of India, said, “The implementation of DRE projects holds the promise of expediting India’s renewable energy advancement due to their shorter turnaround time. DRE projects harness biomass, solar, and hybrid sources, presenting significant potential. Their application extends to benefitting Micro, Small, and Medium Enterprises (MSMEs) and small Commercial and Industrial (C&I) consumers.”

Dr. Dhruva Purkayastha, Director, Climate Policy Initiative, added, “India’s path to green economic growth is pivoted on the collective ability to unlock the huge potential of distributed RE (DRE) in India. By leveraging the power of innovation in terms of falling RE+ storage costs, fostering collaboration across diverse stakeholders, and implementing suitable policy and regulatory interventions, we can create a resilient, equitable, and low carbon distributed clean energy ecosystem for the underserved segments.”

During the day-long Conference, there were four panel discussions:

- Role of DRE in India’s Sustainable Development

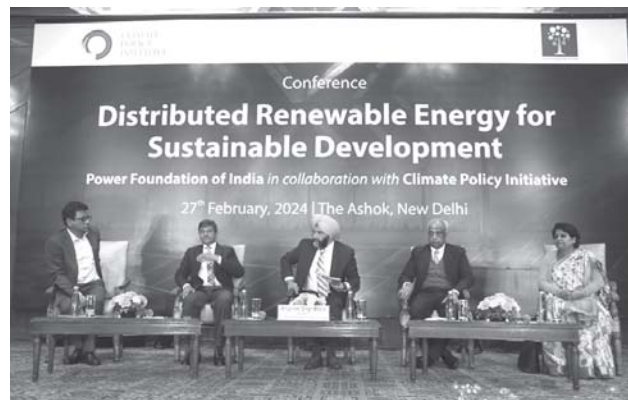

- Empowering Communities – The role of Distributed Renewable Energy in Sustainable Development
- Uptake of DRE solutions for the MSME sector
- Business Models including Financing DRE

The conference delved into the intricacies of DRE projects, exploring their potential to curb energy losses, enhance livelihoods, and foster environmentally conscious manufacturing. Despite successful models in rural India, scaling up remains a challenge, necessitating the identification of impediments and advocating policy actions for broader adoption. The conference was a significant step toward fostering knowledge exchange, raising awareness, and proposing practical solutions for the broader adoption of Distributed Renewable Energy in India’s energy transition and sustainable development-journey.

About Power Foundation of India

Power Foundation of India is a think-tank and a policy advocacy body in the Power Sector. It is a society under the aegis of Ministry of Power, Government of India.

The Foundation undertakes independent, evidence-based research on issues and challenges pertaining to the Power Sector. The research studies encompass diverse aspects related to the generation, transmission, and distribution of power, electricity trading, energy transition, and environmental sustainability.

The Foundation designs and executes campaigns and outreach programs on themes relevant to the Power Sector. Through these engagements, the organization enhances awareness about the Power Sector and motivates people towards environment-friendly behaviour.

<https://www.powerfoundation.org.in>

About Climate Policy Initiative India

Climate Policy Initiative(CPI) is an analysis and advisory organization with deep expertise in finance and policy. Our mission is to support governments, businesses, banks, and financial institutions to drive economic growth while addressing climate change. CPI has six offices around the world in Brazil, India, Indonesia, the United Kingdom, and the United States.

Climate Policy Initiative India Private Limited (CPI India) works to support India's clean energy mission directed by its Nationally Determined Contributions (NDC) through clean energy market catalyzing initiatives, such as the US India Clean Energy Finance (USICEF), India

Clean Energy Finance (ICEF), Productive Use of Renewable Energy (PURE), India Distributed Solar Finance initiative (IDSF), and The Global Innovation Lab for Climate Finance (India Chapter); In addition, CPI India works on capacity building initiatives, such as the Center for Sustainable Finance (CSF); and carries out analytical work for transitioning towards a sustainable energy future, such as Futureproofing Strategy for PSUs, and Just Energy Transition. www.climatepolicyinitiative.org

For further information and inquiries, please contact:

Anurag Bhagat / Saumya Tiwari

Director Communications

Senior Communications Associate

E-mail: anurag.bhagat@powerfoundation.org.in

Saumya.tiwari@cpiglobal.org

REC Signs MoU with Govt. of Rajasthan to Finance Power & Infrastructure Projects Worth ₹20,000 Cr Annually for Next 6 Years



REC Limited, a Maharatna CPSE under the Ministry of Power and a leading NBFC, has signed a Memorandum of Understanding (MoU) on 10th March, 2024 in Jaipur with the Government of Rajasthan, to finance projects across power and non-power infrastructure sectors with an investment of up to ₹20,000 crore per annum for a period of six years, extending up to 2030.

The MoU was signed in the presence of several dignitaries including Shri Bhajan Lal Sharma, Hon'ble Chief Minister of Rajasthan; Smt. Diya Kumari, Deputy Chief Minister, Govt. of Rajasthan; Shri Heera Lal Naagar, Minister of State for Energy, Government of Rajasthan; Shri Sudhansh Pant, Chief Secretary, Govt. of Rajasthan; Shri Amrit Lal Meena, Secretary, Ministry of Coal, Government of India; Shri Vivek Kumar Dewangan, CMD, REC; and CMDs from NTPC, Powergrid, NLC India, and Director, Coal India.

Hon'ble Minister of Power and New & Renewable Ener-



gy, Shri R K Singh and Hon'ble Union Minister of Coal, Shri Prahlad Joshi, addressed the ceremony via virtual conference and extended their best wishes for the initiatives undertaken by the Government of Rajasthan.

Speaking about the agreement, Sh. Vivek Kumar Dewangan, CMD, REC Ltd said, "We are proud to collaborate with the Government of Rajasthan in its mission to enhance infrastructure development across the state. Through this partnership, we aim to support sustainable growth and address the evolving energy needs of the region along with development of other infrastructure sectors."

Under this agreement, REC Limited will provide loans of up to ₹20,000 crores annually for next six years to various departments, undertakings, institutions and schemes of the Rajasthan government. With this MoU, there will be a rapid increase in projects related to the state's infrastructure sector like power projects, metro, roads and

Company News

highways, airports, IT infra, oil refinery, steel infra, ports and waterways, fiber optics, telecom, health sector, tourism infrastructure, agriculture and other infra projects. This collaboration underscores REC's commitment to supporting the development of both power and non-power infrastructure in Rajasthan, thereby contributing to the state's economic growth and prosperity.

On the occasion, MoUs worth ₹1.6 lakh crore were signed by Central Public Sector Undertakings (CPSUs) under the Ministry of Power and Ministry of Coal with the Govt. of Rajasthan. These agreements marked a substantial commitment towards bolstering infrastructure development and driving economic growth in the region.

About REC Limited

REC is a 'Maharatna' CPSE under the Ministry of Power, and is registered with RBI as Non-Banking Finance Company (NBFC), and Infrastructure Financing Company (IFC). REC is financing the entire Power-Infrastructure sector comprising Generation, Transmission, Distribution, Renewable Energy and new technologies like Electric Vehicles, Battery Storage, Pumped Storage projects, Green Hydrogen, Green Ammonia projects etc. Recently, REC has also diversified into the Non-Power Infrastructure sector comprising Roads & Expressways, Metro Rail, Airports,

IT Communication, Social and Commercial Infrastructure (Educational Institution, Hospitals), Ports and Electro-Mechanical (E&M) works in respect of various other sectors like Steel, Refinery, etc. REC Ltd provides loans of various maturities to State, Central and Private Companies for creation of infrastructure assets in the country.

REC Ltd continues to play a key strategic role in the flagship schemes of the Government for the power sector and has been a nodal agency for Pradhan Mantri Sahaj Bijli Har Ghar Yojana (SAUBHAGAYA), Deen Dayal Upadhaya Gram Jyoti Yojana (DDUGJY), National Electricity Fund (NEF) Scheme which resulted in strengthening of last mile distribution system, 100% village electrification and household electrification in the country. REC has also been made the nodal agency for certain States and Union Territories for the Revamped Distribution Sector Scheme (RDSS). REC has also been given the responsibility of PM Surya Ghar Muft Bijli Yojna from Central Government. The loan book of REC stands at ₹4.97 Lakh Crore and Net Worth at ₹64,787 crores as on 31st Dec, 2023.

Contact:

REC Limited

E-mail: receprco@gmail.com

Web: www.recindia.nic.in

KEI Wires & Cables Launching New Product!

Q1. What's the buzz about KEI Wires & Cables launching its new product! Can you provide insights into the launch of KEI Wires & Cables' innovative product, KEI Conflame Green +?

Ans. We at KEI Wires & Cables proudly unveil our vision of the "Next gen living, Eco-friendly solutions" with our upcoming product range that not only connects but also cares. Introducing the highly anticipated product, KEI Conflame Green +. This cutting-edge addition to our lineup is designed to redefine home wiring, emphasizing safety, reliability, and eco-friendliness. Branded as the "Green Wire," it not only connects seamlessly but also reflects our unwavering commitment to sustainability. Choose KEI Conflame Green + for a futuristic wiring solution that not only meets your needs but also cares for the environment. Our launch marks a significant stride toward a greener and safer future.

Q2. What inspired the creation of the innovative product range KEI Conflame Green +?

Ans: The inspiration behind this groundbreaking prod-



uct stemmed from the challenges faced by our existing Conflame range in gaining consumer traction. Recognizing the need for a strategic repositioning, particularly in light of current market dynamics and evolving consumer preferences, we introduced KEI Conflame Green Plus with enhanced safety features.

In response to the growing emphasis on environmental consciousness in the market, driven by both competitors and consumers alike, we seized the opportunity to launch a product that directly addresses these concerns. Our new offering is meticulously crafted to support sustainability initiatives, meeting the rising demand for eco-friendly solutions.

Q3. Can you elaborate on the vision of development of “Next-Gen Living- Eco friendly solution” ?

Ans: “Next-Gen Living Eco friendly solution” reflects our unwavering dedication to delivering innovative solutions that prioritize both Eco-Friendliness and 360-degree safety features. This initiative is designed to resonate with the distinctive needs and priorities of the contemporary millennial consumer, who values environmental consciousness and safety in their lifestyle choices.

Traditionally, manufacturing lacked sustainable eco friendly solutions; however, our new product marks the first stride toward environmental care and a transformative effort. It represents a monumental leap for mankind in sustainable initiatives, exemplified by our groundbreaking product, Conflame Green +.

Q4. What’s the significance behind the comprehensive “Plus” logo, Additionally, could you outline the benefits of KEI Conflame Green +?

Ans: The incorporation of “Plus” in the logo signifies the added benefits of KEI Conflame Green+, showcasing its commitment to comprehensive care for both Inside and outside safety aspects.

Inside safety encompasses features such as excellent HR-Flame-Retardant properties, low smoke density for faster evacuation, and anti-rodent/termite resistance. This not only protects lives but also offers cost-saving advantages

like higher current carrying capacity, increased durability, and better surge voltage withstand capacity.

Outside safety emphasizes sustainability through the KEI Pledge, use of clean gas, efficient waste management, and green energy generation. The eco-friendly aspects include compliance with ROHS & REACH standards, lead-free composition, and biodegradable packaging.

Furthermore, the product boasts cutting-edge technology with various certifications and approvals, including BASEC, ensuring its reliability and adherence to industry standards.

Q5. Which consumer segment is the primary focus for this groundbreaking concept?

Ans: Amidst shifting consumer preferences, our primary target comprises young couples below the age of 35, especially those aspiring to own homes. This demographic holds significant sway in choosing commodity products like wires.

The millennial generation, epitomized by these young couples, demonstrates a dual commitment to environmental sustainability and heightened safety awareness in their purchasing decisions. In response to this nuanced behavior, our innovative tagline “Next-Gen Living” reflects our dedication to aligning with their values. This commitment translates into providing eco-friendly solutions and prioritizing 360-degree safety features, resonating with the distinct needs of the modern, environmentally conscious, and safety-oriented millennial consumer.

Contact:

KEI Industries Limited
D-90, Okhla Industrial Area, Phase-1, New Delhi 110 020
☎ 011 – 2681 8840, 2681 8642
E-mail: info@kei-ind.com

Attention Readers...

*If you are a manufacturer or dealer of any industrial product,
we invite you to
send your Product write-ups for Free publication,
in about 200 words describing the product, such as
its technical specifications, special features, applications, etc,
along with a clear photograph of the product to:*

ipseditor@gmail.com or

The Editor

Industrial Products Source

Product News Publication

104, Sudama Yash, Kelkar Cross Road

Nr: Ramkrishna Hotel, Ram Nagar, Dombivili (E), Thane 421 201

New preservation line placed into existing building containing an overhead crane Improved customer support, optimized manufacturing processes and increased resource efficiency

In order to meet customer demands faster and more efficiently, the Carl Spaeter Hamburg company expanded its range of manufacturing equipment with a preservation line KON 34/6-HD from Rösler that combines shot blasting and painting in one single system. It is designed to handle steel components, up to 3,200 mm wide, 400 mm high and a maximum length of 21.2 metres. The line is equipped with two paint systems. Perfectly integrated into an already existing building containing an overhead crane, the new preservation line allows not only a higher material throughput but also improves the entire production flow resulting in shorter lead times.

Founded in 1905 in the city of Hamburg as hardware store, the Carl Spaeter Hamburg Company became one of the leading steel suppliers for retailers, mechanical contractors and industrial manufacturers in Northern Germany and beyond. The company's success is based on a broad line of steel products with an inventory of more than 25,000 tons, short delivery times, high

operational flexibility and numerous steel processing and refinement services. Mike Barz, general manager at Carl Spaeter Hamburg, explains: "Since our existing shot blast and painting line had reached the end of its usable life, and because we wanted to improve our customer support, we purchased the KON 34/6-HD from Rösler. "The equipment supplier from Untermerzbach in Southern Germany won this substantial purchase order against two competitors for the following reasons: Rösler adapted its equipment concept to the customer's requirements. At

the same time the customer was impressed by the quality and sturdy equipment design and Rösler could show several reference plants in the field. Reyk Hagelberg, plant manager at Carl Spaeter Hamburg, continues: "Within a very short time period Rösler, with input from us, developed a viable equipment concept that was perfectly adapted to our existing building and our technical requirements."

Fully automatic, energy-saving shot blasting

A critical customer demand was that the line must be able to handle steel components, up to 3,200 mm wide, 400 mm high and a length of up to 21.2 meters. Moreover, Rösler had to make sure that steel plates with a thickness of 4 mm could be shot blasted with the same high-quality cleaning results as plates with a thickness of 100 mm. An additional requirement was that all surface areas and edges of steel beams were perfectly blasted and received optimal paint coverage. Since the steel components have a maximum weight of twelve tons, the design of the roller conveyors and cross transport systems had to be extra sturdy.

Special sensors measure the height of the steel components – in the case of steel plates also their width – that have been placed on the inlet roller conveyor of the preservation line. The PLC then automatically determines how many turbines must be turned on to clean the respective components. Other parameters like travel speed, paint type and paint thickness are also part of the processing programs, which are stored in the PLC and can be called up from the operating panel. In a first step the steel com-



The preservation line with shot blast machine and automatic paint system can handle work pieces weighing up to 12 tons. The design was adapted to the existing building containing an overhead crane.

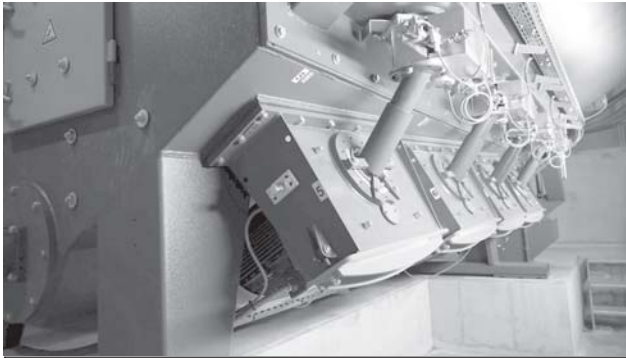

The eight Gamma 400G high-performance turbines with “Y” shaped throwing blade guarantee consistent high-quality shot blasting results.



At the entrance to the automatic paint system special sensors measure the dimensions of the work pieces – down to the last mm.

ponents are passing through a pre-heater that prevents moisture from being carried into the shot blast machine. The exhaust air from the pre-heater is guided to the paint drier, which helps to reduce the drying time of the applied paint.

From the pre-heater the work pieces are transferred to the shot blast machine. The machine housing is made from manganese steel. In addition, the blast chamber is lined with overlapping liners made from manganese steel. Eight high-performance Gamma 400G turbines, each with a drive power of 22 kW, ensure that the specified cleanliness of SA 2, 5 is consistently and safely achieved at a travel speed of up to 4 metres/minute. Compared to conventional blast wheels, the Gamma turbines with curved throwing blades in “Y” design achieve an up to 20 % higher blast performance and, at the same time, reduce the energy consumption. Residual blast media and dust on the shot blasted components is removed with a combined brush-off/blow-off system at the exit of the blast chamber.

Low paint usage and minimal overspray

To meet individual customer requirements for the coating operation utilizing a water-based primer, the integrated automated spraying equipment is equipped with two independent paint application systems. Prior to the paint process special sensors precisely measure the work piece dimensions – down to the last mm. The gantry holding the spray guns is then programmed

for these measurements. This ensures that the primer is only applied onto the surface of the respective steel components. The result is a minimum of overspray and the prevention of unnecessary waste of the valuable resource paint. The paint filter with air extraction points on both sides of the transport system collects any residual paint overspray. The filter is extremely effective! The residual dust load in the clean air is only 0.2 mg/m³

and, therefore, considerably below the official standard specifying a maximum of 1 to 2 mg/m³.

The residual dust in the clean air coming from the dust collector of the shot blast machine amounts to 1 mg/m³, well below the legal limit of maximum 3 mg/m³. Reyk Hagelberg explains: “With the new Rösler preservation line we can run our surface treatment operations for steel plates, beams, pipes/tubes and steel bars not only with an excellent finishing quality but also in a highly eco-friendly manner.” Heating the paint drier with exhaust air from the pre-heating system is a further contribution towards resource-saving operations.

Optimized manufacturing processes and material flow

The work piece transport system of the new preservation line was integrated into a building with overhead crane already existing at Carl Spaeter. The roller conveyors with forward and reverse transport direction cover all four bays of the building with an area of over 42,000 square meters. This arrangement guarantees a highly flexible material handling operation. For example, it allows the transport of steel components from anywhere in the building to the preservation line, to other areas in the building or to the truck load station. The cross-transport systems, placed to the left and right of the roller conveyor, offer plenty of capacity for the intermediate storage of steel components. “With the new preservation line and the resulting further steel processing and refinement possibilities we can fulfill customer requests faster and more efficiently. This helps to reduce our lead times. In addition, the new line, in combination with the roller conveyors and cross-transport systems, improves our logistical setup with shorter walking distances for our employees and streamlines our entire workflow”, concludes Mike Barz.

For more information, please go to:

www.rosler.com

Chamberlain Group Unveils Pune Innovation Center for Advancing Smart Access Solutions

Chamberlain Group (CG), a global leader in smart access solutions and Blackstone Portfolio Company, is proud to announce the opening of its newest Engineering hub, the Chamberlain Group Pune Innovation Center (CPIC). CG's innovative IoT products include garage door openers, gate operators, commercial door openers, and dock-level openers – powered by its myQ technology.

CPIC will be the company's second largest engineering development center, currently located within a 10,000 sq. feet space at the Amar Tech Centre, a new state-of-the-art facility within Pune's Viman Nagar IT hub. There are already 50 engineers on board, with plans to have 150 engineers with expertise that covers Java, Middleware, Embedded Firmware & Hardware, web and mobile development, data engineering, cloud and DevOps, generative AI, and QE –in the next two years. CG's decision to set up CPIC in Pune, India, aligns with its broader vision to augment its team's advanced digital engineering skills, as it transforms from a hardware company to a software-focused, IoT leader.

"We've been innovating new hardware products for over 50 years, and now we're shifting to also be a leader in SaaS, with our myQ Ecosystem at the core," said Dan Phillips, Chief Technology Officer at Chamberlain Group. "This new Innovation Center will play a major role in our transformation and our goal of achieving engineering excellence."

CG partnered with R Systems, a Blackstone portfolio company and global leader in digital product engineering, to help on this journey.

"As Chamberlain's preferred partner, R Systems is committed to bringing the right blend of skills and cultural alignment to this strategic collaboration. We look forward to contributing our digital engineering expertise and talent nurturing acumen to Chamberlain Group's vision of shaping the future of smart access solutions" said Nitesh Bansal, CEO and MD, R Systems International Limited.

R Systems has taken the responsibility of hiring, training, deploying, and transitioning talent for CPIC. R Systems' deep engineering and domain expertise, leadership commitment and their demonstrated ability to build culturally aligned teams were key differentiators that led to CG's decision to select R Systems as their preferred partner.

Jignesh Shah, Head - India Operations, Chamberlain



L-R: Jignesh Shah, Head - India Operations, Chamberlain Group, **Nitesh Bansal**, CEO and MD, R Systems and **Dan Phillips**, Chief Technology Officer at Chamberlain Group.

Group, said, "The opening of CPIC, signifies a pivotal moment in our pursuit of innovation and global excellence in smart access solutions. India is one of the largest talent pools of diverse and skilled engineers for Chamberlain Group and together, we aim to redefine industry standards and bring cutting-edge technology to the forefront."

About Chamberlain Group:

Chamberlain Group is a global leader in intelligent access and Blackstone portfolio company. Our innovative products, combined with intuitive software solutions, comprise a myQ ecosystem that delivers seamless, secure, access to people's homes and businesses. Our recognizable brands, including LiftMaster® and Chamberlain®, are found in 50+ million homes, and 10+ million people rely on our myQ® app daily to control and monitor their homes, communities and businesses, from anywhere. Our patented vehicle-to-home connectivity solution, myQ Connected Garage, is available in millions of vehicles from the leading automakers.

Follow Chamberlain Group on **LinkedIn and Instagram**

About R Systems:

R Systems is a leading digital product engineering company that designs and develops chip-to-cloud software products, platforms, and digital experiences that empower its clients to achieve higher revenues and operational

efficiency. Their product mindset and engineering capabilities in Cloud, Data, AI, and CX enable us to serve key players in the high-tech industry, including ISVs, SaaS, and Internet companies, as well as product companies in telecom, media, finance, manufacturing, health and public services verticals.

R Systems uses its expertise in automation and integration including RPA and No-Code-Low-code platforms to help enterprises across these verticals achieve its OKRs. The Company delivers this by helping them digitize en-

tire value chains and infuse intelligent automation.

R Systems has constantly innovated over 3 decades through applied R&D to solve real-life problems. Its 4200+ technology experts across its delivery centers in India, Eastern Europe and other geographies, use deep understanding of business domains and customer use cases to apply the latest technology stacks in cloud, automation, AI, ML, analytics, and mixed reality. Company's growing team is spread across 18 development centers and 25 offices in North America, Europe, and Asia Pacific.

REC Limited Signs MoU with National Investment and Infrastructure Fund Limited

REC Limited, a Maharatna CPSE under the Ministry of Power and a leading NBFC, has signed a Memorandum of Understanding (MoU) with the National Investment and Infrastructure Fund Limited (NIIFL) to collaborate on a suite of funding solutions for Renewable Energy Projects as well as large-scale infrastructure projects in India.

The MoU was signed in the presence of Sh. Vivek Kumar Dewangan, CMD, REC and Shri Rajiv Dhar, CEO and MD, NIIFL by Shri Daljeet Singh Khatri, ED (Finance), REC, and Sh. Prasad Gadkari, Executive Director & Chief Strategy Officer, NIIFL.

Sh. Ajoy Choudhury, Director (Finance), REC; Sh. V K Singh, Director (Projects), REC; Sh. K Mukundan, Sr. Principal - Strategic Initiatives and Policy Advisory, NIIFL and Sh. Saurabh Rastogi, Executive Director, REC were also present on the occasion and held rich discussions.

Sh. Vivek Kumar Dewangan, CMD, REC said, "Empowering India's growth through strategic financial partnerships, REC Limited remains steadfast in its commitment to fueling the nation's progress. Our commitment to financing key infrastructure projects echoes our shared vision for a robust and interconnected future."

Sh. Prasad Gadkari, Executive Director & Chief Strategy Officer, NIIFL said, "The collaboration with REC aligns perfectly with NIIFL's broader strategy to enhance financing and attract private capital into the infrastructure sector. Through this partnership, we aim to develop innovative financial solutions supporting major infrastructure."

About REC Limited:

REC is a 'Maharatna' CPSE under the Ministry of Power,



and is registered with RBI as Non-Banking Finance Company (NBFC), and Infrastructure Financing Company (IFC). REC is financing the entire Power-Infrastructure sector comprising Generation, Transmission, Distribution, Renewable Energy and new technologies like Electric Vehicles, Battery Storage, Pumped Storage projects, Green Hydrogen, Green Ammonia projects etc. More recently REC has also diversified into the Non-Power Infrastructure sector comprising Roads and Expressways, Metro Rail, Airports, IT Communication, Social and Commercial Infrastructure (Educational Institution, Hospitals), Ports and Electro-Mechanical (E&M) works in respect of various other sectors like Steel, Refinery, etc. REC Ltd provides loans of various maturities to State, Central and Private Companies for creation of infrastructure assets in the country.

For further details, contact:

**Business Development and Marketing (BDM) Division
(Corporate Communications Cell)**

REC Limited

E-mail: reccprco@gmail.com

Products INDEX

A			
AC & AC+DC TRMS Digital Power Clamp-On Meter Model KM 099	15	Car Parking Unit	c-i
AC/DC Energy Meters	5	Carbon Spring Washers	8
Acceleration Sensor	18	Cartonator Pockets	4
ACSR Wire	23	Cartridges	22
Aerial Bunched Cables	c-ii	Cast Iron, Graphite and Ceramic Thermocouple	15
Air Blower	37	CCT / Cat-5 / LAN Cables	c-ii
Air Velocity Kit	11	CCTV Cables	33
Airless 4W Tunnel Type Blasting Machine for Sheet Blasting	c-i	Centrifugal Blowers	3
All Kinds of Other Special Cables	c-ii	Centrifugal Fans	3
Alloy Steels	c-iii	Ceramic Band Heater	15
Ammeter	17	Chain Hoist	c-i
Andon System (i-Smart AndonZ)	5	Chain Pulley Block	c-i
Angle Linear Guideway - Hiwin AG Series	29	Circular Threaded Coupling Connectors	8
Anti-Collision Device	c-i	Clamps for Photo Cells	4
Armchair	c-i	CNC Polygon Turning Machine, Mini Model SPM42	44
Austenitic Stainless Steel Fasteners	34	CNC Turning Machine, SINEWAY 2035	23
Automatic Changeover-cum-Current Limiter (ACCL) M32D	45	Co-axial / Instrumentation / Computer Cables	c-ii
Axial Fan with Aluminium Casing	3	Coil Fastening Nut	c-iv
Axial Fans	3	Coil Winding Machine	18
Axial Flow Fans	3	Coiled & Disc Springs	c-iii
Axial Flow Fans Long Body	3	Cold Work Tool Steels	c-iii
B		Compensating Cables	17
Bag Filtration System	30	Conditional Monitoring Systems	c-i
Balanced Weave Conveyor Belt	40	Conductivity Level Switches	11
Barometer	11	Connectors	c-iv
Bipod	4	Continuous Laser Welder	19
Blast Room and Paint Room System for Rail Chassis Body	c-i	Control Transformer	6
Box Type Inline Fan	3	Conveyors & Components	4
Brackets & Guides	4	Crane Automization	c-i
Building Automation System Cables	31	Crane Kits	c-i
By-Pass Rotameter	11	Crane Limit Switches	7
C		Crane Scale	c-i
Cabinet Fans	3	Cranes & Hoists	c-i
Cable Armour Wire & Strips	35	Cup Coil	c-iv
Cable Trolley	7	Cyclone Scrubbers	35
Cables & Wires	c-ii	D	
Capacitance Type Level Transmitters	11	DC & EC Fans	3
Car Parking Geared Motors	16	DC MIG/MAG/MMA Welder Single/Three Phase	21
		Deep Filter Cartridge	38
		Depaneling Machine	44
		Die Head Thermocouple & PT100 (RTD) Sensors	15
		Die Steels	c-iii

Diffusion Welding Machines	20	Flat Plug with Micro Switch	c-iv
Digital Pressure Gauges	11	Flat Submersible Cables (3-Core)	27
Digital Pressure Switches	11	Flexible / Industrial Cables	c-ii
Digital Temperature Controller	17	Flexible Geared Coupling	c-i
Digital Volt Meter	17	Floor Handling Equipments	c-i
DIN Connectors	c-iv	Flow Switches	11
Disinfectant Concentrate, Multipurpose	37	Flow, Level, Pressure & Temperature Sensors	35
Distribution System	38	Forging Components	c-iii
Dock Leveler	c-i	Forward & Backward Curved Blower Fans	3
Double Girder EOT Cranes	c-i	FR / FRLS / PVC Cables (HT & LT Cables)	c-ii
Double Inlet Blower	3	Fresh Air Fan with HEPA Filter	3
Dry Type Transformers	5	FRP Customizable Field Control	
Dust Collector - Dedusting System	36	Solutions in Weather Proof Enclosures	12
E		FRP Modular Toilets	32
Easymech Premium Quality Drill & Endmill Resharpener Machines	11	Fully Thyristorised MIG/MAG Welding System	21
Eco Flex Nylon Cable Ties	24	Furnaces	17
Electric Chain Hoist	c-i	G	
Electric Motors/Gear Boxes & Drives	12	Gantry Crane	c-i
Electrical Control Panel	20	Gaskets	c-iv
Electrical Furnace	17	Gear Tooth Speed & Direction Sensor	33
Electrical Industrial Hot Air Ovens	17	Glass Tube/Acrylic Rotameters	11
Electrical Products	8	Goliath Crane	c-i
Electrical Products and Spare Parts	6	Goods Lift	c-i
Electro Hydraulic Thrustor Brake	c-i	Graphite Series VMC	25
Electro Hydraulic Thrustor	c-i	Gravity Limit Switch	c-i
Electromagnetic Flowmeter	11	H	
Electronic Timer	17	Head Mount Smart Temperature Transmitter	7
Electro-Pneumatic Brake System for EMU	42	Hepa Filters	28
Elevator Automation Products	14	High Density Cartridge Heaters	15
Energy Monitoring Solutions and Equipments	5	High Engineering Plastic Shaft	4
Engineering Polymer Components	c-iv	High Quality Dry Scrubber	34
EOT Crane Components	7	Hook-up Wires	c-ii
EOT Cranes	29	Hot Work Tool Steels	c-iii
Exhibition	9	Hour Meters & Counters	17
Explosion Proof Rotary Switch	13	House Wiring / Multicore Cables	c-ii
Extensive Dust Collector Machine	27	HT/MV Switch Gears	5
External Rotor Motors	3	Humidity & Temperature Sensors	44
F		Hybrid Solar Power Plant	27
Fasteners & Components	14	Hydraulic Thruster Brakes	7
Fasteners	33 & 34	I	
Fasteners Machinery	21	Impact Sockets	c-iii
Fiber Laser Cutting Machine	28	Indoor and Outdoor LBS	5
Flame Proof / Non Flame Proof Extended Shaft Dual Inlet Blower	3	Industrial Cotton Rope	41
		Industrial Fabric Welders	18
		Industrial Heaters	17

Industrial Ovens	15	Mono Rail Trolley	c-i
Industrial PTFE Tape	41	Motion Control & Automation Solutions	16
Industrial Quality Alloys	41	Motion Control Products	21
Industrial Roboaggregates	39	Moulded Plugs	c-ii
Industrial Solar Batteries	25	MPC Breakers	15
Inline Duct Fans	3	MS Flanges	16
Inline SIVTEK Low Headroom Separator	29	Multi Point Temperature Scanner	17
Insulated Conductor Bar	c-i	Multi Wire Cable Trolley	c-i
Integrated Elevator Intelligent Control System	22	N	
J		New Generation Hoist	c-i
Jib Crane	c-i	Nickel Alloys & Duplex Stainless Steel	40
L		Nickel Alloys Steel Bars	7
LAN Cables	c-ii	Nickel Alloys Steel Products	7
LED Street Light	32	Nickel Alloys Steel Ribbons	7
Lever Limit Switch	c-i	Nickel Alloys Steel Strips	7
Liquid Column Manometers	11	Nickel Alloys Steel Wires	7
Liquid Level Indicators	11	Nozzle Heaters	15
Liquid Level Switches (Float Operated)	11	O	
Liquid Level Transmitter	11	Oil Cooled Transformers	5
Load Cells & Transducers	20	Oil Level Gauge	17
Low Harmonics Regenerative Matrix Convertor	44	Online UPS	30
M		Optical & Electrical Photo Sensor	16
Magnetic Float Sensors	15	Ovens	17
Markmate Pneumatic Marking Machine	24	P	
Master Controller	c-i	Packing Machine	28
Material Handling Equipments	c-i, 11 & 45	Panel Meters	5
MCC Breakers	15	Peripherals for Industrial Automation	27
Measuring Instruments	11	Photo Electric Sensors	15
Medical Gas Pressure Monitor, Alarm and Data Logger 3-in-1 IoT System	10	PhotonX i-Cut	45
Metal Tube Rotameter with Transmitter / Flow Indicator Totalizer	11	PID – Temperature Controller	17
Metallic Expansion Joints (Rectangular and Circular)	14	Pin Type Load Cell	c-i
Mica Band and Nozzle Heaters	29	Pipe Fittings	36
Mica Band Heaters & Cross Head Heaters	15	Plastic Mould Steels	c-iii
Micro Flat Plug	c-iv	Pneumatic Products	13
Micro Lighted Socket	c-iv	Pneumatic Straight Grinder	36
Micro Socket Black	c-iv	Polypropylene Blowers	3
Mini Coil	c-iv	Porcelain Heaters & Elements	15
Mini Super Melt	18	Portable Disintegrator – SPARKMAN	26
Miniature Circuit Breakers	15	Portable Gentry Crane	c-i
Miniature Compression and Tension Load Cell	13	Potentiometers	4
Miniature Thermocouples	17	Power & Control Cables (Aluminium / Copper / Conductor / Armoured Unarmoured Cables)	c-ii
Modular Supports	4	Power Cables	31
		Power Hydraulic Machine Vice	36
		Power Load Relay	15

Power Packs	5	Sen Lighted Socket	c-iv
Powerful Batteries	10	Sen Socket Black	c-iv
Precision Twin Machine Vice	39	Sensors	15
Preservation Line Inline Blasting, Painting and Baking System	c-i	Shear Connector Studs for Arc Welding	26
Pressure Switches	11	Shielded Battery Cables for EVs and Emobility	14
Process Instruments	11	Short Stroke Conductive Plastic Potentiometer	4
Process Pumps	19	Sigma Flex Manual Induction Cap Sealing Machine	22
Proximity Sensors	15	Signal & Instrumentation Cables	8
P-TEF Wire	24	Single & Double Inlet Centrifugal Blowers	3
PTFE Graphite Packing	41	Single Girder EOT Cranes	c-i
PUF Insulated FRP Roofing & Cladding Panels	26	Single Inlet Blower	3
PVC Insulated Industrial Wires & Cables	c-ii	Slim Lighted Socket	c-iv
R		Slim Socket Black	c-iv
Rail Clamps	7	Slip Rings	10
Rail Rubber Pads	34	Socket with Digital Voltmeter Display	c-iv
Railway Plate Screws	30	Socket with Rectifier Circuit	c-iv
Reactors, Autoclaves & Hydrogenators	19	Socket with Surge Suppressor	c-iv
Reciprocating Surface Grinder with Horizontal Spindle	23	Software for CNC Machining Centres 3D Measurement	38
Redio Remote Control	c-i	Solar Cables	c-ii
Reed Switches	25	Solar Generator, Model NOVA-AC300	28
Regenerative Blowers	3	Solenoid Coil	c-iv
Repairing of Automation Products	25	Special Shot Blasting Machine for Cleaning of Submersible Pump Casing	c-i
Resistance Box	c-i & 7	Special Shot Blasting Machine for Fold-away Tray of Sheet Molding Compound	c-i
Reverse Air Bag House	13	Special Shot Blasting Machine for Gear Cutters Tools before PVD Coating	c-i
Roboplast	31	Spring Steels	c-iii
Robotic Deburring of Cylinder Head / Block – RMD Series	38	Spring Washers	8 & 42
Rolling Contact Controlled Automatic Voltage Controller (Stabilizer)	6	Springs for all Purpose	8
Roof Extractor	3	Square & Round Bars	c-iii
Rotary Conductive Plastic Servo Potentiometer	4	Stabilizer	6
Rotary Limit Switch	c-i	Stainless Steel Pipes and Tubes	40
Rotating Electrical Connector	10	Stainless Steel Sheets Plates and Coils	40
Round Shell Connectors	8	Standard Flat Plug	c-iv
Rubber Conveyor Belts	45	Standard Lighted Socket	c-iv
Rubber Tyre Gantry Crane	c-i	Standard Multifunction Polisher r-SONIC	20
S		Standard Socket Black	c-iv
Safeload Controller	c-i	Starter Panels	22
Scissor Platform	c-i	Stationary Wet Scrubbers	35
Scissors Lift	c-i	Steel Wire Products	12
Screws	17	Street Light Control Solutions (SLitZ)	5
Second Screw Punches	19	Strip Heaters	42
Semi Electric Stacker	c-i	Surface Finishing Solution	c-i

T		Turbine Ventilator	31
Telecommunication Cables	c-ii	U	
Temperature Measuring Instruments & Allied Products	11	Utility Meters	5
Test & Measurement & Control Instruments	32	V	
Thermo Well	15	Vacuum Manometer	11
Thermocouples RTDs	17	Vertical Form Fill and Seal Machine, Mini Collar Type	32
Thread Turning	39	VFD & Soft Starter Panels	23
Three Core Flat Submersible Cables	c-ii	Vibrating Fork Switch BT-TFS-XXXX	30
Thruster Brakes	7	Voltmeter Display Connector	c-iv
Thyrister Motor Speed Controller	17	W	
Tile Profile Roofing Sheets	26	Wall Mounted Fans	3
TMT Rebar	24	Welded Pipes and Tubes	39
Tool & Alloy-Special Steels	c-iii	Winch	c-i
Tools – Collets	c-iii	Wire Rod	c-iii
Transfer Trolley	c-i	Wire Rope Hoist	c-i
Transformers	12	Wire Rope Load	Cell c-i
Tripod	4	Wire Wound Servo Potentiometers	4
TRS / TRS Braided / Welding Cables	c-ii	Wireless Calling System (CallBeeZ)	5
Truck Loader and Unloader	c-i	Z	
Tubular Heaters	15	Zero Point Clamping System	33

A D V E R T I S E R S ' I N D E X

B		K	
Bheemas Controls	15	Khanwalkar Industries	8
C		M	
Crane Control Equipments	c-i	MCon Connectors India Private Limited	c-iv
E		Mec Shot Blasting Equipments Pvt Ltd	c-i
Empire Cable Industries Pvt Ltd	c-ii	Moldex Corporation	4
Eyyani Electric Machines Pvt Ltd	3	P	
F		Pankaj Potentiometers Pvt Ltd	4
Fitzer Instruments Company (India)	11	R	
H		RTEX Electronics	8
Haris Sensor Technologies Private Limited	13	S	
Hima Products	17	Sri Bhoomidurga Marketing (P) Ltd	5 & 6
I		T	
INTEC 2024	9	Tacklers Engineering Pvt Ltd	c-i
J		V	
JLC Electromet Pvt Ltd	7	Ventura Alloy and Steels Private Limited	c-iii
		Vijayalaxmi Enterprises	7



Ventura Alloy and Steels Private Limited

We are Importer, Exporter, Stockist, Distributor & Suppliers for Tool & Alloy - Special and Die Steels, Forging Components Spring Steel - Wire Rod, Square & Round Bars Coiled & Disc Springs, Tools Collets, Impact Sockets Etc.



HOT WORK TOOL STEELS



PLASTIC MOULD STEELS



COLD WORK TOOL STEELS



ALLOY STEELS



SPRING STEELS

SUPPLIERS



HOT WORK STEEL

Db6 / AISI L6 / DIN2714
H13 / AISI H13 / DIN 2344
H11 / AISI H11 / DIN 2343
H21 / AISI H21 / DIN 2581
H10 / AISI H10 / DIN 2365
H12 / AISI H12 / DIN 2606

ALLOY STEEL

En24 / AISI 4340 / 40NiCrMo84 / 34CrNiMo6
EN19 / AISI 4140 / 42CrMo4
EN31 / AISI 52100 / 100Cr6
41Cr4 / JIS SCR440H / AFNOR 42C4

COLD WORK STEEL

HCHCR D2 / AISI D2 / DIN2379
HCHCR D3 / AISI D3 / DIN2080
A2 / AISI D2 / DIN 2363
O1 / AISI O1 / DIN 2510
D5 / Cr12MoV / DIN 2601

SPRING STEEL

En47 / 50CrV4 / 51CrV4 / AISI 6150 / SUP10 / DIN 8159
SUP9 / AISI 5155 / DIN 1.7176
SAE 9254 / AISI 9254

PLASTIC MOULD STEEL

P20+Ni / AISI P20+Ni / DIN2738
P20 / AISI P20 / DIN 2311

CARBON STEEL

SAE1080 MS / C45 / EN8D / EN1A / EN1A Pb
C45 / AISI 1042 / JIS S45C
St 52.3 / EN S355JR / JIS SM490A
SAE 1018 / 25CrMo4 / JISCSM420

CASE HARDENING STEEL

20MnCr5 / DIN 1.7147 / SAE 5120 / JIS SMnCr420H / 20MCS
SAE8620
17CrNiMo6 / 18CrNiMo6 / DIN 1.6587 / BS En353

Unit No. 1201 & 1202, Ghanashyam Enclave, New Link Road, Near Laljipada Police Station, Kandivali (West), Mumbai - 400067. Tel: +91 22 35034301 - 307 / 35034311 - 319 Mob: 9819225666 & 8591313565

Stocking / Machining Centre
Gala No. 6, Building No. 183, Indian Corporation, Mouje Gundavli (Mankoli - Phata) Depoda, Taluka - Bhiwandi - 421302
Tel: +91 7977097655 | Email: sales@venturasteels.com | Web: www.venturasteels.com

SOVEREIGN SOLUTIONS FOR ALLOY, SPRING AND DIE STEELS

www.venturasteels.com sales@venturasteels.com +91 22 35034301 - 307 / 35034311 - 319 9819225666 & 8591313565



MCON CONNECTORS INDIA PRIVATE LIMITED

(Previously known as Mcon Connectors)



NEWLY LAUNCHED PRODUCTS

Socket With Rectifier circuit



- Efficiently converts AC voltage to DC and vice versa
- Robust design for durability.
- Seamless conversion between AC and DC at same voltage.

Socket With Digital Voltmeter Display



- 3-Digit Voltmeter Display for real-time voltage monitoring
- Precision-Engineered for optimal performance
- For volatge range upto 24V D.

Socket With Surge Suppressor.



- Integrated surge suppressors for enhanced equipment protection
- Reliable performance in high-demand situations

One Roof Solution For Your Solenoid Coil, DIN Connectors and Engineering Polymer Components.



Scan QR for more details
Or Ask for Detailed Catalog

FOR MORE DETAILS CONTACT AT

Reg Office : C-134, 1st Floor, Ansa Indl. Estate, Saki-Vihar Road, Saki-naka, Andheri (E), Mumbai- 400072. INDIA
 Tel : 91-22-28472222 Mob: +91 9930394422, 9920512555, 9287397244.
 Email : Sales@mcon.co.in, Shaji@mcon.co.in
 Web : www.mcon.co.in
 Factory: Unit No-216 & 212: A wing, 2nd floor, Jai Estate, Plot No- TS-6, Opp.Shivam Hotel, Near SBI,
 (Nr.Vicco Naka, Kalyan-Shil Road) MIDC phase-1, Dombivli (E) -421203 Than(Dist.) Maharashtra, INDIA.